



NEPCO

*A **True** Sign Supply Distributor Serving
the Sign Industry Since 1928*

GRAPHIC AND SIGN Product Catalog

Daily Deliveries Throughout New England ♦ 1-800-327-7562 ♦ 401-438-4550

INDICATED ON THIS PAGE ARE **EXCLUSIVE** AND **UNIQUE** ITEMS AVAILABLE THROUGH NEPCO

NEW ENGLAND SERIES SCROLL BRACKETS

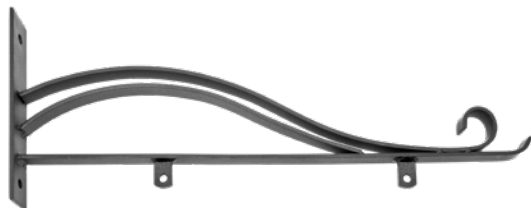

**See Page 51 to view all available New England Series Brackets*

STRAIGHT ARM BRACKETS



**See Pages 52 & 53 to view all available Straight Arm Brackets*

PROJECTION STATIONARY BRACKETS

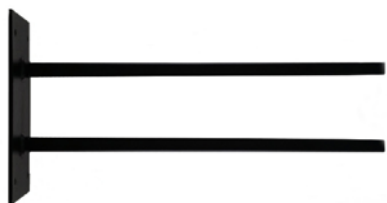

**See Page 54 to view available sizes*

UNIVERSAL SIGN BRACKETS

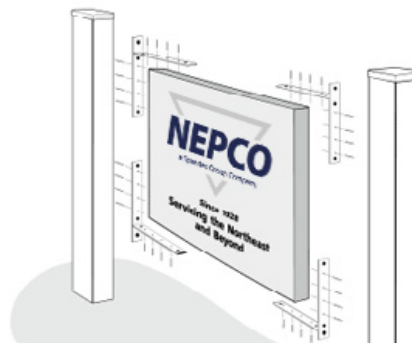

**See Page 55 to view available sizes*

SQUARE ALUMINUM SIGN POST



**See Page 69 to view available sizes*

POST CAPS



**See Pages 70 & 71 to view all available Post Caps*

POST CLIPS



**See Page 58 to view available sizes*

POST BOLTS

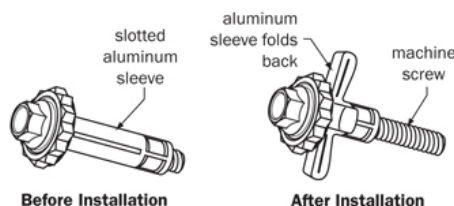

Before Installation

After Installation

**See Page 58 for additional information*

To Our Valued Customer,

NEPCO has been serving the sign, graphics, and awning industry since 1928. We provide only the highest quality sign and awning products at the most reasonable prices in the industry. Our commitment to customer service has earned us thousands of returning customers in the Northeast and beyond.

The NEPCO sales staff is thoroughly knowledgeable in all facets of the sign and awning industry and is prepared to assist you wherever possible.

Just a few reasons why using NEPCO Products will better serve your needs:

- SIGN and AWNING industry sales staff.
- Weekly deliveries to MA, RI, CT, NH, ME and Albany, NY.
- UPS orders ship same day.
- Custom cutting service on Polycarbonate and Aluminum.
- Neon manufacturing and repairs.
- All major credit cards accepted.

Consider choosing NEPCO for your next supply order. You won't be disappointed.

Sincerely,
Your Nepco Team



Order Center Hours

Monday-Friday 7:30AM - 4:00PM

Warehouse/Counter Hours

Monday-Friday 8:00AM - 4:00PM

Accounting and Purchasing>Returns

Monday-Friday 8:30AM - 5:00PM

800-327-7562

401-438-4550

401-438-1533 (Fax)

Our holiday closings can be found on our website.

Payment Methods Accepted



Cash or Company Check

NEPCO Account

COD

Our Office and Warehouse is located at:

125 Amaral Street

East Providence, RI 02915

Ordering

When placing an order, please be certain to give your sales representative all pertinent information i.e. color, size, quantity and all item numbers (if known). Following this procedure will ensure accurate processing of your order. We encourage the use of fax or email.

Returns and Defective Product

Please contact our returns department and a return authorization number will be assigned. All return claims must be made within 30 days of the invoice date. Defective items do not apply. Any unused items must be returned in its original packaging. We reserve the right to charge a fifteen (15%) percent restocking and handling fee on all returnable merchandise.

At no time, will NEPCO accept the return of lamps that are out of their case, even if they were purchased out of their case. NEPCO reserves the right to refuse the return of any item. (Our driver will test all bulbs for you on delivery)

NET Terms

Open accounts are available to qualified companies on credit approval. Open accounts carry net 30 terms with interest charges of one and one half (1.5%) percent per month levied against all delinquent accounts.

To open an account, please contact your sales representative. They will ensure that you are emailed a credit application package from our credit department. Please allow up to 30 days for approval notification. Until such time, all accounts will be on a pre-paid or COD (credit card or company check) basis.

Return of Checks Due to Insufficient Funds

Processing bounced checks is costly, so we will automatically add a \$30.00 charge to your account for any and all checks that do not clear the bank.

Please call us if you have any questions!

Directions from Connecticut & Boston Areas

95 to 195 East take exit 7 (114 Barrington). Take first exit (114 North, Pawtucket Avenue), at end of exit take a left onto Wampanoag Trail, go approximately 200 yds and take a left onto Amaral St. Nepco is located on your right at 125 Amaral St.

Directions from Eastern Massachusetts

195 West take exit 1 (114A Seekonk, Barrington) at end of exit take a left towards Barrington. Go through two traffic lights and bear right following signs to 114A South. Go through one light, immediately bear right onto 114 North, take your first exit (Pawtucket Avenue, 114 North) then take your first right onto Amaral St. Nepco is located on your right at 125 Amaral St.

Delivery & Shipping Options



Nepco offers delivery service throughout New England & nearby New York. Our delivery vehicles are standing by to provide accurate, timely delivery with orders received by 4:00PM the day prior to your scheduled delivery. Please note that the minimum for delivery will vary based on your location. Call our customer service department for your minimum order requirement.



Nepco offers FREE UPS on most graphic supply orders over \$200! This includes ALL cut vinyl, digital products, tapes, blades, inks, etc.* FREE UPS on ALL heat transfer material & accessory orders over \$125. Additional fees will apply to any liquid, oversize item and special packaging. Orders placed before 3:00PM will ship the same day. One transit day to RI - MA - CT - NH - VT - ME (The majority of Maine). Minimums for above graphic supplies & heat transfer material are subject to change without notice.

****UPS has implemented a handling fee per package for anything over 48".**

Free UPS deals on MOST graphic supply orders DO NOT include the following items: Glass Products, Sheeting/ Blanks, Frames/Stakes/Scrolls, Ballasts & Transformers, Wire, Awning Tubing & Fittings, Fabric, Paints & Thinners, Sign Bases & Sign Posts, Lighting Fixtures

TABLE OF CONTENTS / PRODUCT LIST

DIGITAL MEDIA

Premium Media 1-2	Oraguard 290 10	FDC 7262 Static Cling 16
Arlon DPF 4600GLX/MLX 1	Oraguard 290F 10	Orajet 3850 Translucent 17
Arlon DPF 6000 RP Clear 1	Avery DOL 1060z 10	Magic SBL7 Translucent 17
Arlon DPF 6000 XRP 1	Avery DOL 1360z 10	Arlon DPF 6500 Translucent 17
Arlon SLX Cast Wrap 2	Premium Wrap Kit Media 11	Digital Paper 18
Avery MPI 1105EZ 2	Arlon DPF 4600LX 11	Magic GFPOSTER8S 18
Orajet 3751RA 2	Arlon DPF 6000 XRP 11	Magic GFOP212 18
Intermediate Media 3-8	Arlon SLX Cast Wrap 11	Magic GF Photo 18
Orajet 3641 3	Arlon Fusion Wrap 11	Magic GF Photo 240 18
Orajet 3640 3	Wrap Kit Overlaminates 12	Banner Material 19-20
Arlon DPF 510 3	Arlon 3420 12	FDC 752 Mesh 19
Orajet 3164 4	Arlon 3210 12	Arlon DPF 390 19
Orajet 3621 4	Arlon 3170 12	FDC 7501 19
Orajet 3258 4	Arlon 3220 12	FDC 7504 20
Arlon DPF 4500 GLX/MLX 5	Arlon 3270 12	FDC 7508 20
Arlon DPF 4500G 5	Intermediate Overlamine 13-14	FDC 7604 20
Arlon DPF 8200 5	Arlon 3510 13	Printable Heat Transfer Vinyl 21
Orajet 3165 6	Oraguard 200 13	Siser ColorPrint Easy 21
Orajet 3165RA 6	Arlon 3420 13	Siser ColorPrint PU 21
Orajet 3651 6	Oraguard 210 13	Siser ColorPrint Sublithin 21
Orajet 3651RA 7	Oraguard 215 14	Printable Reflective Film 22-23
Orajet 3551RA 7	Arlon 3170 14	Oralite 5600 22
Arlon Fusion Wrap 7	Arlon Protec Series 3960 14	Nikkalite 4800 Series 22
FDC 7270 Series 8	Specialty: Wall & Window Perf 15	Nikkalite M8500 Series 23
Orajet 3850 8	Arlon DPF 4200 15	Arlon DPF 2400 23
Premium Overlamine 9-10	Ritrama 3-2287 15	Oralite 5650RA 23
Arlon 3220 9	ClearFocus Window Perf 15	Film & Canvas Media 24
Arlon 3210 9	Specialty: Translucent 16-17	Magic GFCVM Canvas 24
Arlon 3270 9	FDC 7270 Translucent 16	Magic Stick2 Polypropylene 24
ClearFocus CurvaLam 9	Orajet Transparent 3620 16	

COMPUTER CUT VINYL

High Performance 25-26	Oralite 5600 30	Quick 22KT SignGold 33
Arlon 2100/2200 25	Specialty 31-32	Oracal 383 Ultraleaf 34
Oracal 751 26	Avery SF 100 White Paint Mask 31	Vinyl Efx Metallized 34
Intermediate 27-29	FDC 7262 Static Cling 31	Translucent 35-36
Arlon 4500/4550 CalPlus 27	FDC 4305 Dry Erase Film 31	Arlon 2500 Series 35
Arlon 5000/5050 Series 28	Oracal 8510 Etched 32	Oracal 8500 Series 36
Oracal 651 29	Oracal 6510 Fluorescent 32	Metallics 37
Reflective 30	Metal Polyester Vinyl 33-34	Oracal 951M 37
Nikkalite 4800 Series 30	Oracal 352 Metal Polyester 33	

COMPUTER CUT THERMAL VINYL

Computer Cut Thermal Vinyl 38-42	Siser Glitter Vinyl 40	Siser StripFlock 41
Siser EasyWeed 38	Siser EasyWeed Glow 40	Siser EasyWeed Electric 42
Siser EasyWeed Extra 39	Siser Metallic 41	Siser CADflex 42
Siser EasyWeed Stretch 39	Siser Holographic 41	Siser EasyReflective 42

TABLE OF CONTENTS / PRODUCT LIST

EQUIPMENT

<i>Heat Press Machines</i> 43	Roland Eco-Sol Max Ink..... 46	Roland TRUE-VIS2 Ink 47
<i>Roland Digital Printers</i> 44	Roland Eco-Sol Max2 Ink 46	DuraCoat Edge Foil 47
<i>Plotters/Laminators</i> 45	Roland Eco-UV Ink..... 46	<i>Replacement Blades</i> 48
Graphtec Plotters/Cutters 45	Solaris Eco-Solvent Inks & Flushing	<i>Fletcher Cutters</i> 49
Royal Sovereign Laminators..... 45	Fluid Cartidges..... 46	
<i>Printer Inks</i> 46-47	Roland TRUE-VIS Ink..... 47	

PREMADE PRODUCTS

<i>Brackets</i> 50-59	Chain Link Linklip Bracket 60	<i>Traffic Sign & Post</i> 69
Premium Scroll Bracket..... 50	<i>Divider Bars & Accessories</i> 61	Reflective Traffic Signs 69
Standard Scroll Bracket 50	<i>A-Frames</i> 62-63	Aluminum Sign Posts..... 69
New England Scroll Brackets 51	The Billboard 62	Perforated Steel Square Post..... 69
Wall Mount Straight Arm	Signicade Deluxe..... 62	U-Channel Sign Posts 69
Brackets 52	A-Frame Wellnut 62	<i>Post Caps</i> 70-71
Pole Mount Straight Arm	24 Gauge Steel A-Frame..... 62	Plastic Caps 70
Brackets 53	Signcade 63	Aluminum Caps..... 71
Projection Stationary Brackets..... 54	Quik Sign..... 63	Duracap Post Cap..... 71
Universal Sign Brackets 55	Windsign Frame..... 63	Steel Post Cap..... 71
FastClip No Weld Aluminum	<i>Real Estate Frames & Stakes</i> 64	<i>HDU Blanks</i> 72-73
Bracket System 56	Real Estate Frames..... 64	Carvagio HDU Blanks 72-73
Aluminum Tube Frame Sign	Real Estate Frame Clips 64	<i>SignComp Extrusion Kits</i> 74-75
Brackets & Moldings 57	Step Stakes..... 64	Vandal Systems..... 74
Black “J” Molding 57	<i>Letters & Track</i> 65-67	Standard Rigid Systems 74
Clear “L” Molding..... 57	Pronto Rigid Letters 65	Commercial Rigid Systems..... 75
Chrome Aluminum Tubing..... 57	Acrylic Pronto Letter Tracks 65	EconoComp Rigid Face 75
Post Clip Sign Hanger..... 58	Pronto Letter Change Arm..... 65	<i>Post & Panel System Kits</i> 76
“U” Brackets 58	Flex Changeable Letters 66	3 ¼” Post & Panel System Kits..... 76
Post Bolt Fastener 58	Texas Track 67	SignComp Matching Paint 76
Corner Angle Brackets 59	<i>Sign Bases & Traffic Signs</i> 68	<i>Extrusion Raceways</i> 77
<i>Mounting Brackets</i> 60	Sign Bases 68	5” Narrow Channel Letter
Steel Wall Brackets..... 60	Sign Base Accessories 68	Raceway Bundle 77
Sign Hangers..... 60	Galvanized Steel Round Post..... 68	Socket Raceway II & Cover 77

HARDWARE

<i>Hardware</i> 78	Small Clear Acrylic Block 78	OTC Daihen Long Welding Tip 78
Aluminum Pop Rivet..... 78	Fully Threaded Aluminum Stud 78	OTC Daihen Welding Wire 78

BANNER & SUPPLIES

<i>Banner Stands & Material</i> 79	<i>Banner & Supplies</i> 80	Grommet Hand Press 80
Retractable Economy..... 79	Pre-Grommeted Material..... 80	Ace in the Hole Grommets 80
Retractable Single-Faced..... 79	Banner Bracket Kits 80	Grommet Die Set 80
X-Style Standard 79	Extra Banner Bracket Straps 80	
Lumina 7604 Roll-up Material 79	Grommets 80	

TABLE OF CONTENTS / PRODUCT LIST

SUBSTRATES

ACM Board..... 81-82	Styrene Sheet & Blanks 86	Foamboard 91
Alupanel Standard..... 81	Polycarbonate 87	Encore Foamboard..... 91
Alupanel Lite82	Tuffak Sign Grade Poly87	Encore Mightycore 91
Ecopanel 2 Sided Economy82	Tuffak Printable Poly. Rolls.....87	Encore DuraPrime..... 91
Emaxx Single Sided Economy82	Tuffak Polycarbonate Sheets 87	Flexible Sign & Awning Face..... 92
Multishield82	Vacuum Formed PAN Faces.....87	Cooley-Brite Lite 92
PVC.....83-84	Acrylic 88	Cooley-Brite 92
Celtec Expanded PVC.....83	General Purpose Acrylic	Cooley-Brite II 92
Integral Hard Surface PVC.....84	Sheeting88	Arlon DPF 390..... 92
Multipanel Economy PVC84	P95 Specialty Acrylic88	Aluminum.....93
Aluminum Corrugated	P99 Specialty Acrylic88	Aluminum Sheeting.....93
Polypropylene..... 85	Wood 89	Standard Aluminum Blanks93
Econolite 1-Sided Aluminum..... 85	Scooter Board..... 89	Aluminum/Showcard..... 94
Alumalite 2-Sided Aluminum 85	Laminators LusterBoard 89	Reflective Aluminum Blanks..... 94
PVC Edge Caps 85	MDO Board 89	Aluminum Blanks with Holes 94
Corrugated Plastic..... 86	Extira Treated Wood Comp..... 89	Aluminum Channel Letter Coil..... 94
Coroplast Sheeting..... 86	High Density Urethane/Magnetic.. 90	Showcard.....94
Plastic Blanks 86	SignFoam4 HDU Sheeting 90	
Coroplast Blanks..... 86	Magnetic Sheeting 90	

GRAPHIC TOOLS

Squeegees..... 95	Foamboard Straight Cutter.....96	Applicators 98
Blue Economy95	Orange Xtreme Magnets.....96	EZ Gripper Media & Vinyl
3M Gold95	4¾" Sharp Point Tweezers.....96	Handling Tool98
Felt (Rectangle).....95	Complete Weeding Kit.....96	4" Roller Applicator98
White Oracal Teflon.....95	1 ½" Rivet Brush.....96	Pro-Roll Tape Applicator.....98
Yellow Oracal Felt Edge95	Knives & Blades 97	Tack Roller.....98
6" Plastic Felt Edge95	OFLA 180 Standard Cutter..... 97	Tack Roller Cleaning Sheets.....98
12" Plastic.....95	OFLA Auto-Lock Knife 97	Pro-Tabletop Applicator98
Siser Squeegee.....95	OFLA Carbon Steel Snap Off	Storage Roll Racks 99
Squeegee Sharpener.....95	Replacement Blade 97	Jumbo Wall Media Storage.....99
Lil' Chizler Vinyl Remover95	Corrugated Plastic Cutter..... 97	HD Mobile Floor Rack.....99
Graphic Tools 96	Craft Knife 97	Wall Mount Material Rack99
Xtreme Cutting Mat.....96	Craft Replacement Blades 97	
Big Blue Safety Ruler.....96	Replacement Razor Blades..... 97	

GRAPHIC SUPPLIES

Solutions..... 100	Cotton Gloves 101	Polyethylene D/F Foam Tape 103
Grafix Gone..... 100	Velcro 102	Double Face Seam Tape 104
SPLASH Applicator Fluid..... 100	Nylon..... 102	Tuff Tape III D/F Banner Tape..... 104
Window Juice 100	Polyester 102	PowerTape Banner Tape 104
Action Tac Application Fluid.....100	Tapes 103-104	3M 200 Tape: Masking Tape..... 104
3M Woodgrain/Stripe Removal 100	3M 4949 VHB D/F Tape 103	Packaging Tape 104
Useful Supplies..... 101	3M 4905 VHB D/F Tape 103	Application Tape..... 105
Avery Paper Bond..... 101	3M 4622 VHB D/F Tape 103	R-Tape 4075 Conform RLA..... 105
Tara Bond Paper 20lb..... 101	3M 4950 VHB D/F Tape 103	R-Tape AT-65N Prem. Clear..... 105
Stabilo Marking Pencil..... 101	Oracal 3601 UHB D/F Tape..... 103	R-Tape AT-60N Prem. Clear..... 105
Vinyl Clips 101	Oracal 3597 UHB D/F Tape 103	Value Tape Standard Grade 105

TABLE OF CONTENTS / PRODUCT LIST

PAINT & SUPPLIES

Primers..... 106	Specialty Paints/Additives108-110	1-Shot Ti-Cote Clear Primer
Chromatic Metal & Wood	1-Shot Lettering Enamel 108	Barrier Coat..... 110
Primer 106	Chromatic Bulletin Enamel 109	Lettering Brushes 111
Chromatic Block-Out Primer..... 106	Chromatic White Background	Lettering Quill..... 111
Chromatic Universal Waterbase	Enamel..... 109	Fitch Brush..... 111
Primer 106	1-Shot Chromaflo 6000 Flow	Truck Flat Lettering Brush..... 111
Jay Cooke's Paint Primer All	Enhancer 110	Sword Striping Brush..... 111
Purpose..... 106	1-Shot High Temp. Reducer 110	Striping Quill..... 111
Frog Juice..... 106	1-Shot Solvent Hardener 4007.... 110	Finishing Brushes & Rollers 112
Gold & Smalts.....107	1-Shot Speed Dry UV Acrylic 110	Acid Brush..... 112
Smith's Cream..... 107	1-Shot Brush Conditioner &	Touch Up Brush 112
Smalt Glass 107	Cleaner 110	60W Chip Brush..... 112
Luco Fast/Slow Set Dry 107	Chromatic Clear Flattening	Poly-Brush..... 112
Gold Leaf Patent 107	Paste 110	Poly Roller 112
Gold Leaf-Loose..... 107	1-Shot Low Temp. Reducer..... 110	

TRIM & MOLDING

Specialty Trim & Molding..... 113-114	Clear Aluminum "L" Molding 114	Chrome Aluminum Tubing..... 114
PVC Edge Cap Trim..... 113	Econo Retainer Molding..... 114	Hand Notcher..... 114
Channel Letter Trim..... 113	Standard Retainer Molding..... 114	
Black Aluminum "J" Molding 114	Aluminum "U-Cap" Edge Cap 114	

LED

LED Lamp Replacement 115-116	JS LED Standard Module 121	Keystone LED Power Supply..... 130
Keystone Double Face	Skyline Rigid Border Tubing 122	LED Accessories 131-132
Lamps 115-116	RGB3 System Module for Channel	Allanson Stormtight LED Dimer.. 131
LEDs for Channel Letters 117-121	Letters 123	WallBuster Through Wall
Allanson LEDgen2 Standard LED	RGB DMX & WiFi Controllers..... 124	Insullator..... 131
Module..... 117	RGB LED Controllers..... 125	Paige LED Power Supply Box..... 131
Allanson Econo Module 118	RGB Accessories..... 126	Paige Rip Strip LED Wire..... 132
Allanson LEDgen2 Mini LED	LED Power Supplies 127-130	Paige Plus LED Wire Jacketed ... 132
Module..... 119	Allanson Power Supply 127	
Allanson Low Profile LED	Universal Power Supply 128	
Module..... 120	JS LED Power Supply 129	

ELECTRIC FLUORESCENT

Accessories 133	Disconnect Switch with Boot 133	Sylvania High Output Lamps..... 135
Fluorescent High Output Lamp	Fluorescent Ballasts Wire 133	Voltarc High Output Long Boy
Holders (Sockets) 133	Ballasts/Lamps 134-135	Lamps 135
Socket Sentry Boots..... 133	Allanson RSS HO Ballast..... 134	High Output Junction Box 135
Socket D-Punch 133	Allanson EESB HO Ballast 134	
Fluorescent Awning Light	Universal HO Ballast 134	
Fixtures..... 133	Keystone HO Ballast 135	

TABLE OF CONTENTS / PRODUCT LIST

ELECTRIC NEON

<i>Transformers/Transformer</i>		
Box..... 136-137	Ceramic Cable Support..... 138	Connector..... 141
Allanson Self Regulating	Slipstick High Tension Cable	Neon/Fluorescent Pro Tube
Outdoor..... 136	Bushing..... 138	Tester..... 141
Allanson Standard Outdoor..... 136	Electrode Short Sleeve	Peanut Glass Housings..... 141
Allanson Self-Regulating / Self	Insulator..... 139	Large Glass Housings..... 141
Enclosed..... 136	Electrode Housing Cap	Small Glass Housings..... 141
Allanson Standard / Self	Insulator..... 139	Small Porcelain Housings..... 141
Enclosed..... 137	Ceramic Federal Bushing..... 139	EGL Extreme Cold Gas K4
Allanson Indoor Electronic Window	High Voltage Junction Box..... 139	Blue..... 142
Style..... 137	Electrode Cap Insulator..... 139	EGL Extreme Cold Neon Gas..... 142
Ventex Channel Letter..... 137	Electrode Straight Boot	Mercury..... 142
Ventex Transformer Enclosure	Insulator..... 139	Glass Neon Tubing - Voltarc..... 142
Box..... 137	Blow Hose..... 140	Glass Neon Tubing - EGL
Neon Accessories..... 138-142	Brass Electrode Caps..... 140	Accuwall..... 142
Prewired Glass Tube Supports... 138	Igloo Housing Cap Insulator..... 140	Voltarc Masonlite Millennium
Plastic Quik-Supports..... 138	Neon Bending Hand Block..... 140	Electrodes..... 142
Copper Wire Tie..... 138	Inland 33 Vacuum Oil..... 140	Custom & Stocking Neon..... 143
GTO Wire..... 138	Diffusion Pump Oil..... 140	
	Metal Conduit Screw-In	

ADHESIVE

Specialty..... 144-145	Weld-On 3 Adhesive..... 144	Weld-On Large (400mL) Gun..... 145
GE Silicone Adhesive/Sealer..... 144	Weld-On 66 Adhesive..... 144	Weld-On Mixing Tips..... 145
Weld-On 45 Adhesive..... 144	Weld-On 58 Adhesive..... 144	Glue Applicator Bottles..... 145
Weld-On 16 Adhesive..... 144	Weld-On Small (50mL) Gun..... 145	

Looking for
AWNING/MARINE
Supplies?



Call for your
FREE catalog!

or visit our website www.nepcosignsupply.com
to view the catalog online!

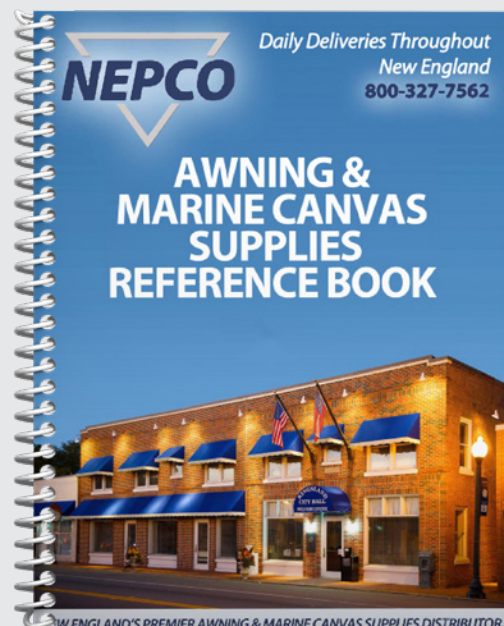

NEW ENGLAND'S PREMIER AWNING & MARINE CANVAS SUPPLIES DISTRIBUTOR



ARLON

DPF 4600LX 3.2 mil • 7 Year • Premium Pressure Sensitive Vinyl Film

Light Grey Solvent Based Tinted Clean Removing, Repositionable Adhesive

Eco-Solvent - Solvent - Latex - UV

DPF 4600LX is a white gloss high performance film with a tinted, clean removing, repositionable adhesive system. The repositionable light gray adhesive allows for easy installation while ensuring enough opacity for covering up existing graphics or dark substrates. The new LX (Low Profile) X-Scape Technology provides installers the benefit of a bubble-free installation combined with a smooth printed surface that doesn't show the pattern through the print. DPF 4600LX works great for vehicle graphics & wraps.



Recommended Applications:

- Vehicle Wraps and Decals
- Window & Tradeshow Graphics
- Real Estate Signage
- POP Displays
- Other Standard Signage

SKU	SIZE	COLOR
40L6-3015-102	30" x 50YD	White Gloss
40L6-5415-102	54" x 50YD	White Gloss

Wrap Kits Available!

40L6-KIT30-GLS

40L6-KIT54-GLS

see page 11



ARLON

DPF 6000 RP Clear 2.0 mil • 7 Year • Premium Clear Cast Film

Clear Solvent Based Pressure Sensitive Permanent Adhesive

Eco-Solvent - Solvent - Latex - UV

DPF 6000RP Clear is a gloss clear cast film with clear, high tack, permanent pressure-sensitive adhesive. Designed for large format graphics, DPF 6000RP Clear is made of premium quality cast face stock with a special lay-flat liner. The special adhesive system is designed to provide easy installation.



Recommended Applications:

- Windows
- Second Surface Signs
- Fleet Graphics
- Full/Partial Vehicle Wraps
- Standard Signage (Permanent)
- Backlit Signage

SKU	SIZE	COLOR
46P0-3015-000	30" x 50YD	Clear Gloss
46P0-5415-000	54" x 50YD	Clear Gloss



ARLON

DPF 6000 XRP 2.0 mil • 7 Year • Premium Clear Cast Film

Light Grey Solvent Based Clean Removing, Repositionable Adhesive

Eco-Solvent - Solvent - Latex - UV

DPF 6000XRP is a gloss white cast film with bubble releasing, tinted, clean removing, repositionable, permanent pressure-sensitive adhesive. The X-Scape Technology™ allows installers to achieve speedy installation while maintaining a high enough tack to ensure long-term bond. Designed for large format graphics, DPF 6000XRP is made of premium quality cast facestock with a lay-flat liner. The adhesive system is designed to provide excellent opacity & easy installation. The film provides superior conformability around rivets, curves, contours & channels.



Recommended Applications:

- Full/ Partial Vehicle Wraps
- Fleet Wraps
- Multipurpose Commercial

SKU	SIZE	COLOR
46R0-5407-002	54" x 25YD	White Gloss
46R0-3015-002	30" x 50YD	White Gloss
46R0-5415-002	54" x 50YD	White Gloss

Wrap Kits Available!

46R0-KIT30-GLS

46R0-KIT54-GLS

see page 11



SLX™ Cast Wrap 2.0 mil • 7 Year • Premium Cast Digital Film

Light Grey Clean Removing, Repositionable Adhesive

Eco-Solvent - Solvent - Latex - UV

SLX™ Cast Wrap is a premium gloss light grey repositionable cast film with FLITE Technology™. Designed for the single installer, this film allows for a fast wrap and superior repositionability for full and partial, vehicle and fleet applications. FLITE Technology is a light contact system allowing graphics to float over a substrate until firm pressure is applied. It guarantees the fastest installation while ensuring long-term bond, conforming effortlessly around rivets, complex curves & deep channels.



Recommended Applications:

- Vehicle Wraps
- Vehicle Graphics & Decals
- Fleet Graphics

SKU	SIZE	COLOR
70X0-3015-102	30" x 50YD	White Gloss
70X0-5415-102	54" x 50YD	White Gloss

Wrap Kits Available!

70X0-KIT30-GLS

70X0-KIT54-GLS

see page 11



MPI 1105EZ 2.1 mil • 7 Year • Wrapping Cast Digital Film

Grey Permanent Acrylic Adhesive

Eco-Solvent - Solvent - Latex - UV

MPI 1105EZ SuperCast Series Vinyl is a premium gloss opaque vinyl designed for use in fleet marking and vehicle wrap as well as corporate identity applications. MPI 1105 provides superior conformability to irregular surfaces such as compound curves and corrugations Easy Apply™ and Easy Apply™ RS features offer the benefits of reduced wrinkling and air entrapment inherent in the application of decals. The RS feature also provides repositionability and slide-ability for exact positioning. Graphics can be over laminated or clear coated with a UV screen print clear.



Recommended Applications:

- Full or Partial Vehicle Wraps
- Outdoor Signage
- Boat Wraps and Graphics

SKU	SIZE	COLOR
MPI1105EZ-54G	54" x 50YD	White Gloss



Orajt 3751RA 2.25 mil • 8 Year • Wrapping Cast Film

Grey Solvent Based Repositionable Permanent Low Tack Adhesive

Eco-Solvent - Solvent - Latex - UV

Orajt 3751RA is an ideal choice for challenging vehicle wraps, ORAJET® Series 3751RA features a low initial tack, repositionable adhesive, cast construction and an advanced air release system for highly conformable performance over difficult curves, corrugations and rivets. Series 3751RA is a film with a smooth surface producing vivid, life-like prints that can be removed with little or no adhesive residue for up to four years.



Recommended Applications:

- Long-term
- Outdoor Signage
- Complex Vehicle Wraps

SKU	SIZE	COLOR
3751RA-30	30" x 50YD	White Gloss
3751RA-54	54" x 50YD	White Gloss

ORAFOL **Orajet 3641** 3.0 mil • 4 Year • Soft Calendered PVC Digital Media

Grey Water Based Permanent Adhesive

Eco-Solvent - Solvent - Latex - UV

Orajet 3641 is an economical 3 mil, 4 year digital film. Great for short-to medium-term indoor and outdoor applications that require vivid colors and images. ORAJET 3641 features a grey, permanent adhesive that is typically used for a variety of outdoor signage applications, P.O.P. and exhibitions.



Recommended Applications:

- Decals
- Name Plates
- Die-Cut Letters
- Pop Displays

SKU	SIZE	COLOR
3641-30-G	30" x 50YD	White Gloss
3641-54-G	54" x 50YD	White Gloss

ORAFOL **Orajet 3640** 3.0 mil • 4 Year • Soft Calendered PVC Digital Media

Clear Water Based Permanent Adhesive

Eco-Solvent - Solvent - Latex - UV

Orajet 3640 is most economical and popular inkjet films, 3 mil, 4-year ORAJET 3640 provides vivid images and great colors for short to medium-term indoor and outdoor applications. ORAJET 3640 features a clear, permanent adhesive and is typically used for a variety of outdoor signage and banner applications.



Recommended Applications:

- Decals
- Name Plates
- Die-Cut Letters
- Pop Displays

SKU	SIZE	COLOR
3640-30-G	30" x 50YD	White Gloss
3640-54-G	54" x 50YD	White Gloss
3640-30-M	30" x 50YD	White Matte
3640-54-M	54" x 50YD	White Matte



DPF 510 3.2 mil • 3 Year • Intermediate Digital Film with 2 Sided Polycoated Liner

Clear/Grey Solvent Based Permanent Adhesive

Eco-Solvent - Solvent - Latex

DPF 510 is a 3.2-mil calendered film with a clear or grey, solvent-based pressure-sensitive adhesive. The two-sided polycoated liner provides excellent lay-flat properties. The high-quality adhesive provides far superior adhesion and cohesion properties than water-based adhesive. Available in a white gloss & white matte finish.



Recommended Applications:

- Short to Medium-Term Signage
- Real Estate Signage
- POP Displays
- Tradeshow Displays
- Kiosks

SKU	SIZE	COLOR
4051-5415-002	54" x 50YD	White Gloss*
4051-3015-002T	30" x 50YD	White Gloss
4051-5415-002T	54" x 50YD	White Gloss
4051-5415-202T	54" x 50YD	White Matte

*Clear Adhesive

DPF 510 is one of the most economical and best value intermediate vinyl that you can purchase!

ORAFOL **Orajet 3164** 4.0 mil • 4 Year • Soft Calendered PVC Digital Media

Clear Water Based Permanent Adhesive

Eco-Solvent - Solvent - Latex - UV

Orajet 3164 is an inkjet media is a great choice for vibrant shorter-term applications. ORAJET 3164 has a clear, water-based permanent adhesive & is ideal for a variety of outdoor signage applications, including short-term promotions.



Recommended Applications:

- Short to Medium-term General Signage
- Decals
- Name Plates
- Die-Cut Letters
- Pop Displays

SKU	SIZE	COLOR
3164-30-G	30" x 50YD	White Gloss
3164-54-G	54" x 50YD	White Gloss
3164-30-M	30" x 50YD	White Matte
3164-54-M	54" x 50YD	White Matte

ORAFOL **Orajet 3621** 3.0 mil • 4 Year • Soft Calendered PVC Digital Media

Grey Water Based Removable Adhesive

Eco-Solvent - Solvent - Latex - UV

Orajet 3621 is an economical calendered inkjet media for short-term interior and exterior graphics that **require easy removal**. ORAJET 3621 has a water-based, removable, grey-pigmented adhesive that delivers great covering power. Designed for flat-surface applications.



Recommended Applications:

- Short to Medium-term General Signage
- Decals
- Name Plates
- Die-Cut Letters
- Pop Displays

SKU	SIZE	COLOR
3621-54-G	54" x 50YD	White Gloss
3621-54-M	54" x 50YD	White Matte

ORAFOL **Orajet 3258** 6.0 mil • 4 Year • Semi Rigid Permanent Adhesive

Grey Solvent Based Permanent Adhesive

Eco-Solvent - Solvent - Latex - UV

Orajet 3258 is the perfect film for those moments when you don't want to use an over-laminate or application tape but still need the stability and ease of installation that a 6 mil film provides.

NEW!



Recommended Applications:

- Bumper Stickers
- Point of Purchase Displays
- Promotional Multi-Color Labels & Decals

SKU	SIZE	COLOR
3258G-30	30" x 100'	Gloss White
3258M-30	30" x 100'	Matte White
3258G-54	54" x 100'	Gloss White
3258M-54	54" x 100'	Matte White

Helpful Tip!

Rolling digital media tightly around the core after printing will cause the solvent gases in the inks to be trapped. These gases could potentially migrate to the adhesive layer of the material, resulting in poor adhesion properties once applied to the intended substrate.



DPF 4500 GLX/MLX 3.0 mil • 5 Year • Intermediate Calendered Digital Vinyl Film

Light Grey Opaque Solvent Based Permanent Adhesive

Eco-Solvent - Solvent - Latex - UV

DPF 4500 GLX/MLX is constructed of a 3-mil white calendered film offered in gloss or matte and coated with tinted, bubble releasing, permanent pressure-sensitive adhesive. The LX (Low Profile) X-Scape System allows installers to achieve speedy installation while maintaining high enough tack to ensure long-term bond. The polymeric facestock allows for vibrant prints combined with ease of application for short and medium-term graphics.



Recommended Applications:

- Short to Medium-Term Signage
- Real Estate Signage
- POP Displays
- Tradeshow Displays
- Kiosks

SKU	SIZE	COLOR
40X5-3015-122	30" x 50YD	White Gloss
40X5-4815-122	48" x 50YD	White Gloss
40X5-5415-122	54" x 50YD	White Gloss
40X5-3015-149	30" x 50YD	White Matte
40X5-5415-149	54" x 50YD	White Matte



DPF 4500 G 3.0 mil • 5 Year • Intermediate Calendered Print Media

Clear Solvent Based Permanent Adhesive

Eco-Solvent - Solvent - UV

DPF 4500 G is a calendered film with permanent pressure-sensitive adhesive. Designed for indoor and outdoor promotional graphics, DPF 4500G White is made of a calendered facestock with a polycoated liner. The special glossy facestock is designed for applications requiring high gloss or more image "pop."



Recommended Applications:

- POP Displays
- Second Surface
- Windows
- Medium-Term Graphics

SKU	SIZE	COLOR
4045-3015-100	30" x 50YD	Clear Gloss
4045-5415-100	54" x 50YD	Clear Gloss
4045-6015-100	60" x 50YD	Clear Gloss
4045-5415-122	54" x 50YD	White Gloss



DPF 8200 3.5 mil • 7 Year • Industrial Grade Film for Hard-to-Stick Surfaces

Clear High Tack Permanent Adhesive

Eco-Solvent - Solvent - Latex - UV

DPF 8200 High Tack is a 3.5-mil (90 micron) satin white, high-tensile, PVC film with aggressive, permanent pressure-sensitive adhesive. The film is made of a 100% engineering-grade facestock with a polycoated lay-flat liner. The unique low shrink adhesive system enhances dimensional stability, improving printer handling and converting time. Designed to adhere to slightly textured outdoor wall substrates such as brick, tile, and concrete, the film also has exceptional performance on low surface energy substrates such as polypropylene, polyethylene, and powder coated paints. DPF 8200 High Tack is fire certified under ASTM E-84.



Recommended Applications:

- Outdoor Wall Graphics
- Large Graphics
- Low Surface Energy Plastics
- Decals
- General Signage

SKU	SIZE	COLOR
4082-3015-002	30" x 50YD	White Satin
4082-5415-002	54" x 50YD	White Satin

ORAFOL **Orajet 3165** 4 mil • 5 Year • Intermediate Calendered PVC Digital Media

Grey Solvent Based Permanent Adhesive

Eco-Solvent - Solvent - Latex - UV

Orajet 3165 is ideal for general signage applications over flat surfaces including yard signs, banners, and displays. In addition to its advanced air-release liner system, this 5-year, 4 mil film features a glossy surface to produce vivid, life-like prints and a grey-pigmented solvent-based adhesive for improved durability and covering power.



Recommended Applications:

- Short to Medium-Term General Signage

SKU	SIZE	COLOR
3165-54-G	54" x 50YD	White Gloss
3165-54-M	54" x 50YD	White Matte

ORAFOL **Orajet 3165RA** 4 mil • 5 Year • Intermediate Calendered PVC Digital Media

Grey Solvent Based Permanent Adhesive

Eco-Solvent - Solvent - Latex - UV

Orajet 3165RA has all the same features as 3165 but also with Rapid Air Egress technology to facilitate quicker, easier application and less bubbles. It features a glossy surface to produce vivid, life-like prints and is a repositionable grey-pigmented solvent-based adhesive for improved durability and covering power.
*Not designed for vehicle wrapping



Recommended Applications:

- Short to Medium-Term General Signage
- Flat, Indoor & Outdoor Applications

SKU	SIZE	COLOR
3165RA-30-G	30" x 50YD	White Gloss
3165RA-54-G	54" x 50YD	White Gloss

ORAFOL **Orajet 3651** 2.5 mil • 5 Year • Intermediate Calendered PVC Film

Clear Solvent Based Permanent Adhesive

Eco-Solvent - Solvent - Latex - UV

Orajet 3651 is a special PVC film developed for digital printing. It is perfect for brilliant and colorful displays for digital large format prints in outdoor applications. It provides excellent adhesion to metals and other surfaces without any shrinkage in cross direction.

NEW!

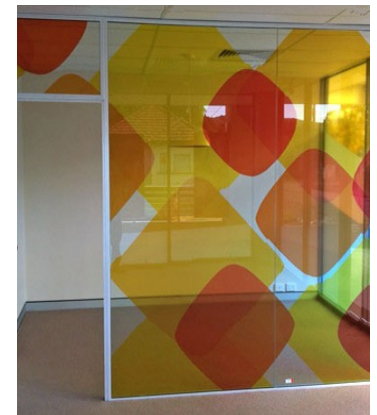

Recommended Applications:

- General Signage
- Medium-Term, Flat, Indoor & Outdoor Applications

SKU	SIZE	COLOR
3651-30-G	30" x 50YD	White Gloss
3651-36-G	36" x 50YD	White Gloss
3651-54-G	54" x 50YD	White Gloss
3651-54-M	54" x 50YD	White Matte
3651-54-G-000	54" x 50YD	Clear Gloss
3651-60-G-000	60" x 50YD	Clear Gloss

ORAFOL **Orajjet 3651RA** 2.75 mil • 5 Year • Intermediate Calendered PVC Film

Grey Solvent Based Adhesive

Eco-Solvent - Solvent - Latex - UV

Orajjet 3651RA media provides vivid images and great colors for short to medium term indoor and outdoor applications. Also, with the Rapid Air release glue technology the 3651RA provides easy installation of large flat graphics. Both of these medias provides vivid images and great colors for short to medium term indoor & outdoor applications.
*Not for vehicle wraps.



Recommended Applications:

- Short to Medium-Term General Signage
- Flat, Indoor & Outdoor Applications

SKU	SIZE	COLOR
3651RA-54-G	54" x 50YD	White Gloss

ORAFOL **Orajjet 3551RA** 2.75 mil • 7 Year • Intermediate Calendered PVC Digital Media

Grey Solvent Based Repositionable Permanent Adhesive

Eco-Solvent - Solvent - Latex - UV

Orajjet 3551RA is suitable for everything from building signs for easier vehicle applications. The vinyl adhesive is removable permanently making it possible to reposition the vinyl for 30 minutes after application. 3551RA makes it possible to make perfect air bubble-free installation thanks to the unique Rapid Air technology. The film has the microscopic ducts carrying out any air and that can be removed, with heat, with little or no adhesive residue for up to four years.



Recommended Applications:

- Short to Medium-Term General Signage
- Vehicle Graphics Requiring Limited Conformability

SKU	SIZE	COLOR
3551RA-30	30" x 50YD	White Gloss
3551RA-54	54" x 50YD	White Gloss



Fusion Wrap 2.4 mil • 7 Year • Intermediate Digital Calendered Film

Light Grey Solvent Based Repositionable Permanent Adhesive

Eco-Solvent - Solvent - Latex - UV

Fusion Wrap featuring FLITE Technology® can be the product of choice in various situations: when cost-driven opportunities are presented, if shorter to medium term durability is specified, or when a flat to simple curve vehicle wrap application is present. The lite initial contact adhesive system from FLITE Technology® will ensure repositionability, developing a quick anchor tack to speed up installations.



NEW!

Recommended Applications:

- Short or Medium-term Vehicle Wraps & Graphics With Simple to Moderate Curves

SKU	SIZE	COLOR
FUSION5450	54" x 50YD	Gloss White

Wrap Kits Available!

FUSION545KIT
see page 16

*Pair with Arlon 3170 intermediate cast overlaminates for the thinnest hybrid installation.

Lumina FDC 7270 Series 3.2 mil • 5 Year • Intermediate Grade Calendered Translucent Vinyl

Clear Solvent Based Permanent Adhesive

Eco-Solvent - Solvent - Latex - UV

FDC 7270 is an intermediate grade calendered translucent vinyl film designed for printing backlit graphics and signage requiring medium-term durability.

Recommended Applications:

- Backlit Graphics
- Signage Requiring Medium-Term Durability

SKU	SIZE	COLOR
7270-5415-049	54" x 50YD	White Matte



ORAJET Orajet 3850 3.0 mil • 7 Year • Translucent Calendered Digital Media

Clear Solvent Based Permanent Adhesive

Eco-Solvent - Solvent - Latex - UV

Orajet 3850 is a high-performance, 3-mil, 7-year translucent inkjet media which is excellent for producing brilliant backlit signage, both indoors and out. ORAJET® 3850 features a semi-gloss finish for reduced glare and a clear, permanent adhesive for internally illuminated applications that last.

Recommended Applications:

- Long-Term Use on Rigid Substrates in Backlit Indoor/Outdoor Applications

SKU	SIZE	COLOR
3850-30	30" x 50YD	White Semi Gloss
3850-54	54" x 50YD	White Semi Gloss



Do you know the difference between Solvent Based Adhesives and Water Based Adhesives?

Solvent-Based Adhesives

Solvent-based products are designed for more demanding and longer term applications. The components of this adhesive are combined using solvents, thus allowing a structurally stronger adhesive that is more resistant to chemicals, cleaning agents and wider temperature ranges.

Another important attribute is the ability to wet apply graphics without worry of the adhesive losing bond to the substrate.

Water-Based Adhesives

Products with a water-based adhesive, typically are a low-cost solution for either indoor or short-term outdoor graphic applications. This type of adhesive is found in a wide range of versatile projects like decorative wall graphics, indoor wall murals & way finding signage.

Avoid wet applications when applying water-based adhesive products as this will interfere with the bonding process to the substrate.

DIGITAL MEDIA

PREMIUM OVERLAMINATE



Series 3220 2.0 mil • 7 Year • Premium Cast Overlaminates

Clear Solvent Based Permanent Adhesive

Arlon 3220 is designed to protect and prolong the life of printed images for window applications. *This product is not designed to be used as an optically clear window film.*

Recommended Applications:

- Vehicle Wraps
- Indoor Signage
- Outdoor Signage
- Wall Wraps

SKU	SIZE	COLOR
3220G-3015-000*	30" x 50YD	Clear Gloss
3220G-5415-000*	54" x 50YD	Clear Gloss
3220L-5415-100*	54" x 50YD	Clear Luster
3220M-3015-800	30" x 50YD	Clear Matte
3220M-5415-800*	54" x 50YD	Clear Matte
3220S-3015-200	30" x 50YD	Clear Satin
3220S-5415-200	54" x 50YD	Clear Satin



Wrap Kits Available!

3220-KIT30-GLS
3220-KIT54-GLS
3220-KIT54-MAT
3220-KIT54-LSTR

see page 12



Series 3210 1.3 mil • 7 Year • Premium Cast Overlaminates Pressure-Sensitive Film

Clear Solvent Based Permanent Pressure Sensitive Adhesive

Arlon 3210 is designed to protect printed images and prolong the life of the printed images. Series 3210 provides the same protection as our standard overlaminates while having excellent conformability during installation with a lighter weight film. The gloss finish provides an extra pop to printed graphics. This product is not designed to be used as an optically clear window film.

Recommended Applications:

- Vehicle Wraps
- Fleet Graphics
- Building Wraps
- Long-Term Signage

SKU	SIZE	COLOR
3210-5415-000	54" x 50YD	Clear Gloss



Series 3270 2.0 mil • 7 Year • Premium Cast Overlaminates Pressure-Sensitive Film

Clear Permanent Pressure Sensitive Adhesive

Arlon 3270 overlaminates is a premium cast overlaminates available in a gloss finish and is designed to protect and extend the life of printed graphics. Whether your application demands installation into deep channels, rivets, compound curves or a smooth wall, Series 3270 can offer lasting performance and durability. Series 3270 extends the life of the graphics by 2 years. ***Specifically recommended for use with SLX Cast Wrap**

Recommended Applications:

- Vehicle Graphics
- Vehicle Decals
- Fleet Graphics

SKU	SIZE	COLOR
3270G-3015-000	30" x 50YD	Clear Gloss
3270G-5415-000	54" x 50YD	Clear Gloss

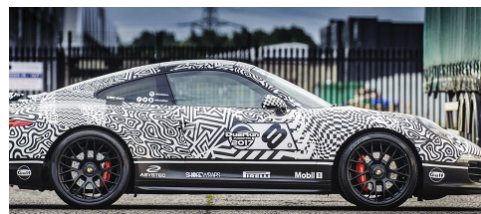

Wrap Kits Available!

3270-KIT30-GLS
3270-KIT54-GLS

see page 12

Clear Focus® - CurvaLam 3.0 mil • 2 Year • Optically Clear Cast Vinyl

Permanent Pressure-Sensitive Adhesive

CurvaLam is designed to protect and prolong the life of printed images for **perforated window applications**, CurvaLam is made of high quality, 100% polymeric face stock.

Recommended Applications:

- Window Graphic Films
- Glass or Transparent Surfaces

SKU	SIZE	COLOR
CFCVL54X25	54" x 25'	Clear Gloss



ORAFOL Oraguard 290 2.0 mil • 8 Year • Premium Cast PVC Laminating Film

Clear Solvent Based Adhesive

Oraguard 290 is one of the most durable and conformable cast PVC laminating films. ORAGUARD 290 can be used for a wide range of longer-term indoor or outdoor applications, including fleet and large graphic applications. ORAGUARD 290 is an 8-year, 2-mil, highly flexible cast film with a clear, solvent-based adhesive. It has a UV protection extension factor of 4 years. Recommended for cold lamination.



Recommended Applications:

- Protection of Long-Term Indoor/Outdoor Digital Print Applications

SKU	SIZE	COLOR
290-30-G	30" x 50YD	Clear Gloss
290-48-G	48" x 50YD	Clear Gloss
290-54-G	54" x 50YD	Clear Gloss
290-54-M	54"x 50YD	Clear Matte

ORAFOL Oraguard 290F 2.0 mil • 8 Year • Optically Clear Premium Cast PVC Laminating Film

Clear Solvent Based Permanent Adhesive

Oraguard 290F is a 2-mil, 8-year optically clear cast film specially designed for use with perforated window graphics films and other applications where the highest levels of clarity & transparency are needed. Available in gloss finishes with a UV protection extension factor of 4 years. Recommended for cold lamination.



Recommended Applications:

- Protection of Long-Term Indoor/Outdoor Digital Print Applications

SKU	SIZE	COLOR
290F-36-G	36" x 50YD	Clear Gloss
290F-54-G	54" x 50YD	Clear Gloss

AVERY DOL 1060z 2.1 mil • 5 Year • Premium Cast Overlaminates

Clear Permanent Acrylic Adhesive

Avery DOL 1060z has maximum UV protection. Improves solvent, UV curable and latex inkjet outdoor image durability up to 5 years. Good abrasion resistance. Excellent adhesion to graphic materials and great transparency.



Recommended Applications:

- Vehicle Wraps
- Floor Graphics
- Outdoor Signage

SKU	SIZE	COLOR
DOL1060Z-54-G	54" x 50YD	Clear Gloss

AVERY DOL 1360z 1.3 mil • 5 Year • Optically Clear Cast Ultra Conformability

Clear Permanent Acrylic Adhesive

Avery DOL 1360z A premium quality, ultra-thin, ultra-conformable cast vinyl film designed for use as a protective overlaminates film for solvent, UV, latex, and screen print inks. The gloss film now features a synthetic liner that creates a super smooth high gloss finish which provides an overall paint like finish of printed graphics. *1360Z is designed to be used with MPI 1105 SuperCast Series print media. **See page 2***



Recommended Applications:

- Ultra Conformable for Vehicle Wrap & Window Perf Applications

SKU	SIZE	COLOR
DOL1360Z-54-G	54" x 50YD	Clear Gloss

Overlaminates makes the graphic film thicker which makes it easier to handle and reposition without destroying the image!

DIGITAL MEDIA

PREMIUM WRAP KIT MEDIA



DPF 4600LX High Performance Multi-Purpose Film With Low Profile X-Scape Technology®

Light Grey Solvent Based Tinted Clean Removing, Repositionable Adhesive

Eco-Solvent - Solvent - Latex - UV 3.2 Mil Premium Print Media

Ideal for interior & exterior intermediate signage. Great for medium-term vehicle graphics with simple to moderate curves. The new LX (Low Profile) X-Scape Technology® provides installers the benefit of a bubble-free installation combined with a smooth printed surface that doesn't show the pattern through the print.

SKU	SIZE	COLOR
40L6-KIT30-GLS	30" x 50YD	White Gloss
40L6-KIT54-GLS	54" x 50YD	White Gloss

With Compatible Overlaminates: 3210



DPF 6000 XRP Premium Cast Multi-Purpose Film With X-Scape Technology®

Light Grey Solvent Based Clean Removing, Repositionable Adhesive

Eco-Solvent - Solvent - Latex - UV 2 Mil High Performance Cast

Digital printing with a wide variety of direct print systems. Fleet and full or partial vehicle applications. Warrantied for use on rivets, corrugations and channel structures. With its excellent opacity, superior conformability, and a strong bond that will work on vehicles, windows & most standard sign surfaces.

SKU	SIZE	COLOR
46R0-KIT30-GLS	30" x 50YD	White Gloss
46R0-KIT54-GLS	54" x 50YD	White Gloss

With Compatible Overlaminates: 3220



SLX™ Cast Wrap Premium Cast Film with Flite Technology™

Light Grey Clean Removing, Repositionable Adhesive

Eco-Solvent - Solvent - Latex - UV 2 Mil Premium Cast Media

The superior repositionability of SLX Cast Wrap + FLITE Technology® provides a long-term bond where it counts: deep channels, complex curves, and rivets. Ideal for full or partial vehicle and fleet wraps, and large decals. Fast, easy application for the novice and experienced installers. Easy liner release maintaining the integrity of the graphic.

SKU	SIZE	COLOR
70X0-KIT30-GLS	30" x 50YD	White Gloss
70X0-KIT54-GLS	54" x 50YD	White Gloss

With Compatible Overlaminates: 3270



Fusion Wrap High Performance Digital Calendered Film With FLITE Technology®

Light Grey Clean Removing, Repositionable Adhesive

Eco-Solvent - Solvent - Latex - UV 2.4 Mil Premium Cast Media

Great for vehicle wraps & graphics with simple to moderate curves. Lite initial contact that forms a strong bond. Fusion Wrap features a low profile air egress liner and has a tinted, permanent pressure-sensitive adhesive that creates enough opacity to ensure a vibrant print. Superior conformability and stretch for a polymeric wrap film.

SKU	SIZE	COLOR
FUSION5450	54" x 50YD	White Gloss

With Compatible Overlaminates: 3170

**Pair with Series 3170 intermediate cast overlaminates for the thinnest hybrid installation.*

Fusion Wrap



DPF 4600LX



SLX™ Cast Wrap



DPF 6000 XRP

Picking the right vinyl film can be crucial to meeting your customer's expectations, but choosing to add an overlaminate is just as important. Arlon's protective overlaminates deliver ease of application, extra graphic protection, and a variety of different finishes to give your graphic extra vibrancy.



Series 3420 (Intermediate)

Clear Solvent Based Permanent Adhesive

Partial Wrap - 3.0 mil

SKU	SIZE	COLOR
3420-KIT30-GLS	30" x 50YD	Clear Gloss
3420-KIT54-GLS	54" x 50YD	Clear Gloss
3420-KIT30-SAT	30" x 50YD	Clear Satin
3420-KIT54-SAT	54" x 50YD	Clear Satin



Series 3210 (High Performance)

Clear Solvent Based Permanent Adhesive

Partial/Full Wraps - 1.3 mil

SKU	SIZE	COLOR
3210-KIT54-GLS	54" x 50YD	Clear Gloss



Series 3170 (High Performance)

Clear Solvent Based Permanent Adhesive

Partial/Full Wraps - 1.3 mil

SKU	SIZE	COLOR
3170-KIT54-GLS	54" x 50YD	Clear Gloss

Did you know?

Overlaminates acts like a "sunblock" to your printed graphics and helps protect your graphics from scratches, dirty debris and UV exposure.



Series 3220 (High Performance)

Clear Solvent Based Permanent Adhesive

Partial/Full Wraps - 2.0 mil

SKU	SIZE	COLOR
3220-KIT30-GLS	30" x 50YD	Clear Gloss
3220-KIT54-GLS	54" x 50YD	Clear Gloss
3220-KIT54-MAT	54" x 50YD	Clear Matte
3220-KIT54-SAT	54" x 50YD	Clear Satin
3220-KIT54-LSTR	54" x 50YD	Clear Luster



Series 3270 (High Performance)

Clear Permanent Pressure Sensitive Adhesive

Partial/Full Wraps - 2.0 mil

SKU	SIZE	COLOR
3270-KIT30-GLS	30" x 50YD	Clear Gloss
3270-KIT54-GLS	54" x 50YD	Clear Gloss

Mix & Match Overlaminates & Vinyls

Have you ever wondered how to choose the right overlaminate for your large-scale graphic application? Did you know that the right overlaminate will increase the life of your graphics as much as 50%? Overlaminates are just as important as the vinyl choice itself.

The common misconception about this topic is that you cannot mix and match cast overlaminate with a polymeric or monomeric vinyl. This is not true, and here's why. As long as the overlaminate is a higher quality than the underlying printed vinyl itself, you can mix and match it. You never want to put a lower quality overlaminate over a cast vinyl because this will cause shrinkage & edge curl.



Cast Overlaminate
over a
Polymeric OR
a **Monomeric Vinyl**
is **OK**



Polymeric Overlaminate
over a
Monomeric Vinyl
is **OK**



Always put a
Cast Overlaminate
over a
Cast Vinyl



DO NOT put a
Polymeric or Monomeric
Overlaminate
over a **Cast Vinyl**

DIGITAL MEDIA

INTERMEDIATE OVERLAMINATE



Series 3510 3.2 mil • 3 Year • Intermediate Calendered Overlaminates

Clear Permanent Pressure Sensitive Adhesive

Arlon 3510 is a 3.2-mil (80 micron) calendered film with a clear, permanent pressure-sensitive adhesive. Designed to protect your printed image, Series 3510 is made of a monomeric facestock and is recommended for use with DPF 510.



Recommended Applications:

- Short-Term Signage
- Kiosks
- POP Displays

SKU	SIZE	COLOR
3510-54-G	54" x 50YD	Clear Gloss
3510-54-M	54" x 50YD	Clear Matte



Oraguard 200 2.5 mil • 2 Year • Intermediate Calendered Overlaminates

Clear Water Based Permanent Adhesive

Protect your prints and your bottom line. **ORAGUARD® 200** is a 2-year, 2.5-mil film that offers inexpensive protection for shorter-term promotional graphics, along with one-year of additional UV protection for qualified inks when used in outdoor applications. Recommended for cold lamination.



Recommended Applications:

- Short-Term Signage
- Indoor/Outdoor Flat Applications

SKU	SIZE	COLOR
200-50-G	50" x 50YD	Clear Gloss



Series 3420 3.0 mil • 5 Year • Intermediate Calendered Overlaminates

Clear Solvent Based Permanent Adhesive

Arlon 3420 is constructed of a 3-mil (75 micron) calendered vinyl film with clear, permanent pressure-sensitive adhesive. Designed to protect and prolong the life of printed images, Series 3420 is made of a polymeric facestock and available in gloss, satin and matte finishes.



Recommended Applications:

- Promotional Graphics
- Short-Term Signage
- Kiosks
- POP Display
- Partial Wrap

SKU	SIZE	COLOR
3420-3015-100	30" x 50YD	Clear Gloss
3420-4815-100	48" x 50YD	Clear Gloss
3420-5415-100	54" x 50YD	Clear Gloss
3420-3015-000	30" x 50YD	Clear Satin
3420-5415-000	54" x 50YD	Clear Satin

Wrap Kits Available!

- 3420-KIT30-GLS
- 3420-KIT48-GLS
- 3420-KIT54-GLS
- 3420-KIT30-SAT
- 3420-KIT54-SAT

see page 12



Oraguard 210 2.5 mil • 4 Year • PVC Laminating Film

Clear Solvent Based Permanent Adhesive

Oraguard 210 is a laminating film, provides solid protection for digital prints in short- to medium-term indoor & outdoor applications. Recommended for cold lamination. Provides a UV extension factor of 2 years for your outdoor prints.

Recommended Applications:

- Short- to Medium-term Indoor & Outdoor Applications

SKU	SIZE	COLOR
210-30-G	30" x 50YD	Clear Gloss
210-30-M	30" x 50YD	Clear Matte
210-36-G	36" x 50YD	Clear Gloss
210-54-G	54" x 50YD	Clear Gloss
210-54-M	54" x 50YD	Clear Matte
210-54-SG	54" x 50YD	Clear Semi Gloss
210-60-G	60" x 50YD	Clear Gloss

ORAFOL® Oraguard 215 2.75 mil • 5 Year • PVC Laminating Film

Clear Solvent Based Permanent Adhesive

Oraguard 215 is a durable 5-year, 2.75-mil laminating film has been specially manufactured to protect digital prints used in outdoor and backlit signage. ORAGUARD® 215 film is recommended for cold lamination. Provides a UV extension factor of 3 years for your outdoor prints.

Recommended Applications:

- Protection of Medium to Long-Term Indoor/Outdoor Digital Print
- Vehicle Graphics
- Flat application ONLY

SKU	SIZE	COLOR
215-54-G	54" x 50YD	Clear Gloss
215-60-G	60" x 50YD	Clear Gloss



ARLON Series 3170 1.3 mil • 7 Year • Intermediate Calendered Overlaminates

Clear Solvent Based Permanent Adhesive

Series 3170 overlaminates is a 1.3 mil gloss intermediate cast overlaminates with clear, permanent pressure-sensitive adhesive. Designed to protect printed graphics, the thinner facstock of Series 3170 provides a higher conformability for your vehicle wraps, intermediate signage, & graphics. This product is not designed to be used as an optically clear window film, or to be used with cast digital films.

Recommended Applications:

- Long Term Wraps & Signage

SKU	SIZE	COLOR
3170-54-000	54" x 50YD	Clear Gloss



NEW!

ARLON ProTec Series 3960 12 mil • 2 Year • Intermediate Calendered Overlaminates

High Tack Permanent Adhesive

ProTec Series 3960 is the solution for heavy-duty or power sport applications exposed to high levels of abrasion, acting as an extremely durable barrier to protect decals and graphics while maintaining excellent clarity. ProTec Series 3960 is a flexible, high performance, 12-mil overlaminates on a clear synthetic liner with a quick "wet-out" adhesive system keeping ultimate gloss retention and pristine image quality. With efficiency top of mind, ProTec Series 3960 is designed to be laminated cold, without heat.

Recommended Applications:

- Heavy Duty to Protect Against Abrasion

SKU	SIZE	COLOR
3960-5403-100	54" x 10YD	Clear Gloss
3960-5407-100	54" x 25YD	Clear Gloss



NEW!

Laminating & Contour Cutting Using ProTec Series 3960

Contour Cutting Tips

Prior to the contour cutting process, all heaters (pre, print and post) on hybrid devices such as Roland XR-640 (with cutter and printer in one) must be turned off and allowed to cool to room temperature.

- Highly recommended to use a dedicated contour cutter that can reach at least 300gF in cut force.
- For contour cutters that cannot reach 300gF, 2-3 cut passes can be performed if your cutter is capable of that function.
- Use a 60° tough OEM blade (super-steel or cemented carbide) that is intended for thick materials.
- Lower the speed of the cutter to protect the blade.
- Perform many test cuts to ensure proper cutting conditions are met before beginning the job.

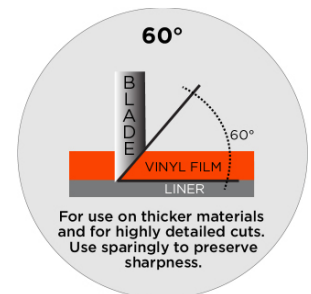
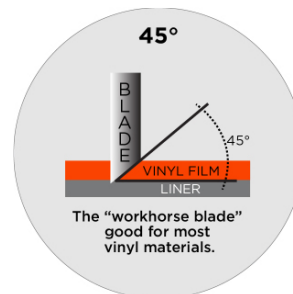

Laminating Tips

ProTec Series 3960 is designed to be laminated cold. All heaters in the laminator should be turned off prior to the lamination process.

- Keep the production area clean and dust free to prevent particulates from contaminating the lamination process.
- Use a static string or static bar that is grounded to the frame of the laminator to reduce static.
- Use proper tension to ensure that 3960 is laminating straight.

DIGITAL MEDIA

SPECIALTY — WALL & WINDOW PERFORATED



DPF 4200 6.0 mil • 1 Year • Removable Interior Wall Vinyl

Clear Solvent Based Permanent Adhesive

Thermal Transfer - Screen

FDC 4200 Series Intermediate Ultra High Gloss Vinyl Film – This is an ultra high gloss calendered vinyl film. This product is recommended for outdoor and indoor uses where a high quality marking film is needed for flexibility, durability and resistance to sunlight. This film can be used for architectural signage, P.O.P graphics and decals, banners, striping, window graphics and lettering

Recommended Applications:

- Indoor Advertising
- Tradeshow Graphics
- Retail Displays
- POP Display
- Home Decor

SKU	SIZE	COLOR
4042-5407-202	54" x 25YD	White Matte
4042-5407-222	54" x 25YD	White Canvas



How to Get a Dust Free Surface

Use our **Tack Roller & Cleaning Sheets** to remove every spec of unwanted dust and other particles from surfaces before printing, laminating or applying graphics.

Available in Medium or High Tack

See page 98 for additional information



Ritrama 3-2287 6.0 mil • 2 Year • 60/40 Window Perforated Exterior Surface Application

Solvent Based Semi Permanent Removable Adhesive

Eco-Solvent - Solvent - UV

3-2287 is a matte white vinyl laminated onto black vinyl and perforated (this version has 40% open area -1.5 mm holes) in order to print on one side and to see through the other side. The semi-permanent acrylic adhesive is repositionable and easy to remove after application.

Recommended Applications:

- Outdoor and transit advertising
- Point of purchase displays
- Novelty products
- Window glazing

SKU	SIZE	COLOR
3-2287-5433	54" x 33'	White Gloss



Clear Focus® - ClassicVue 8.0 mil • 2 Year • 50/50 Window Perf. Exterior-Mount Film

Clear Removable Acrylic Pressure-Sensitive Adhesive

Eco-Solvent - Solvent - UV

ClassicVue's smaller hole diameter and 50/50 pattern make it ideal for vehicle/fleet window graphics. Exterior-mount window graphics for buses and other vehicles, bus shelters, retail signage, event centers and a wide variety of other applications.

Recommended Applications:

- Vehicle Window Wraps
- Medium-Format Retail
- Commercial Window Signage

SKU	SIZE	COLOR
CFEABW54X25	54" x 25'	Clear Gloss



Lumina FDC 7270 3.2 mil • 5 Year • Intermediate Grade Calendered Translucent Vinyl

Clear Solvent Based Permanent Adhesive

Eco-Solvent - Solvent - Latex - UV

FDC 7270 is an intermediate grade calendered translucent vinyl film designed for printing backlit graphics and signage requiring medium-term durability.

Recommended Applications:

- Backlit Graphics
- Signage Requiring Medium-Term Durability

SKU	SIZE	COLOR
7270-5415-049	54" x 50YD	White Matte



ORAFOL Orajet 3620 3.0 mil • 4 Year • Transparent PVC Window Graphics Digital Media

Clear Water Based Removable Adhesive

Eco-Solvent - Solvent - Latex - UV

Designed for window graphics such as storefronts or POP retail applications. Also, beneficial for applications where background color or substrate must remain visible. **Suggested for laminating with Oraguard 210 - see page 13**

Recommended Applications:

- Storefronts
- POP Retail
- Window Graphics

SKU	SIZE	COLOR
3620-30-G	30" x 50YD	Clear Gloss
3620-54-G	54" x 50YD	Clear Gloss



Lumina 7262 Static Cling 7.5 mil • 3 Months • Calendered Gloss Media

Blockout - No Adhesive - N/A

Eco-Solvent - Solvent - Latex - UV - Screen - Thermal

Lumina 7262 Static Cling print media is a calendered gloss static cling vinyl film designed for printing window graphics & decals. 40°F minimum application temp. Interior or smooth extension & non-perforated.

Recommended Application:

- Glass Application
- Decals

SKU	SIZE	COLOR
7262-WHT-1508	15" x 25	Gloss White
7262-CLR-1508	15" x 25	Gloss Clear
7262-WHT-3008	30" x 25	Gloss White
7262-CLR-3008	30" x 25	Gloss Clear



Helpful Tip!

Graphics that are trimmed or plotted directly through the ink within 24 hours after printing can begin to show signs of curling or shrinking around the perimeter once applied to the substrate.

Why does this occur?

The freshly printed (uncured) solvents used in the inks to print the graphic are migrating around the cut line and irritating the perimeter of the adhesive layer. This in turn causes the edges of the material to curl up or shrink either on the release liner or once applied to the substrate.

DIGITAL MEDIA

SPECIALTY — TRANSLUCENT

Orajet 3850 3.0 mil • 7 Year • Translucent Calendered Digital Media

Clear Solvent Based Permanent Adhesive

Eco-Solvent - Solvent - Latex - UV

Orajet 3850 is high-performance, 3-mil, 7-year translucent inkjet media and is excellent for producing brilliant backlit signage, both indoors and out. ORAJET® 3850 features a semi-gloss finish for reduced glare and a clear, permanent adhesive for internally illuminated applications that last.

Recommended Applications:

- Long-Term use on rigid substrates in backlit Indoor/Outdoor Applications

SKU	SIZE	COLOR
3850-30	30" x 50YD	White Semi Gloss
3850-54	54" x 50YD	White Semi Gloss



SBL7 8 mil • Universal Polyester Translucent Backlit Film

Eco-Solvent - Solvent - Latex - UV

SBL7 is the universal non-adhesive polyester backlit film with a matte surface. It is ideal for backlit signage applications and provides maximum transmitted and reflected ink density, ensuring vivid color and high image resolution. It has excellent scratch resistance and does not require lamination.

Recommended Applications:

- Backlit Displays
- Menu Signs
- General Signage
- Retail Advertising
- Trade Show & Installation Graphics

SKU	SIZE	COLOR
SBL-7-36-WHT	36" x 100'	White Matte



DPF 6500 2 mil • 7 Year • Premium Translucent Cast Film

Clear Solvent Based Permanent Adhesive

Eco-Solvent - Solvent - Latex - UV

DPF 6500 is a gloss white, cast, translucent film with a permanent pressure-sensitive adhesive. Designed for backlit graphics, DPF 6500 is made of a premium cast facestock with a special lay-flat liner. The film provides superior print resolution and image quality.

Recommended Applications:

- Windows
- Second Surface Signs
- Backlit Signage

SKU	SIZE	COLOR
4065-3015-020	30" x 50YD	White Gloss
4065-5407-020	54" x 25YD	White Gloss



Helpful Tip!

Polycarbonate outgases for a period of time after manufacturing, which can cause bubbles in your vinyl. To prevent this, remove the protective film as soon as possible and allow the polycarbonate to outgas naturally for at least 24 hours before applying the vinyl (longer if possible).



GFPOSTER8S 8 mil • Coated 1 Side Printable White, Promotional

Eco-Solvent - Solvent - Latex - UV

Magic GFPOSTER8S is an 8 mil premium poster paper with a superior satin finish. The award-winning Magic satin coating produces vibrant colors for long lasting, fade resistant prints.

Recommended Applications:

- General Posters & Signage
- Retail Advertising
- Photo Reproduction
- Wall Murals

SKU	SIZE	COLOR
GFPOSTER8S-30	30" x 150'	White Satin
GFPOSTER8S-54	54" x 150'	White Satin



GFIOP212 9.9 mil • Heavy Weight, Coated 1 side, Wet Strength, High Resolution

Aqueous - Eco-Solvent - Solvent - Latex - UV

GFIOP212 is a 9.9 mil latex-saturated, wet-strength paper for indoor banners, outdoor posters and wall coverings. One-side coated paper designed to meet the demands of high production solvent and eco-solvent ink jet printers. This latex-saturated, wet strength paper features a smooth surface which offers exceptional print fidelity with a distinctive luster finish. Strength, flexibility and durability are hallmark traits of GFIOP. It resists cracking when folded, and film lamination is not required in most intended applications.

Recommended Applications:

- Indoor/Outdoor Short Term Use
- Wall Coverings
- Posters
- Promo Signage

SKU	SIZE	COLOR
GFIOP212-54	54" x 150'	White Luster



GF Photo 7 mil • Light Weight Photo, Realistic, High Resolution

Eco-Solvent - Solvent - Latex - UV

GF Photo is a premium satin photorealistic paper specifically designed for solvent, eco-solvent, latex, and UV cure printers. Indoor use unless encapsulated with a safe edge.

Recommended Applications:

- Posters
- Displays
- Window & Wall Coverings
- Trade Show

SKU	SIZE	COLOR
GFPHOTO-54	54" x 100'	Bright Wht. Gloss



GF Photo 240 10 mil • Heavy Weight Photo, Realistic, High Resolution

Eco-Solvent - Solvent - Latex - UV

GF Photo 240 is a unique, durable heavy weight photographic paper for solvent inkjet printers. It is ideal for photographic, portrait and fine art reproductions as well as suitable for posters, maps and display graphics that may require more stiffness and durability.

Recommended Applications:

- Fine Art
- Indoor Use
- Window Photo Portrait

SKU	SIZE	COLOR
GFPHOTO-240-50	50" x 100'	Bright Wht. Gloss



DIGITAL MEDIA BANNER MATERIAL

Lumina **FDC 7521 Mesh** 8 oz • 1 Year • White Polyester Mesh - 1 Sided

Opacity: >75%

Eco-Solvent - Solvent - Latex - UV

7521 Mesh is mesh PVC banner designed for printing general purpose signage and displays. It features a PVC liner on the back side to be removed after printing & a 63% surface area with 37% air flow. This material is tear, curl & fire resistant.

Recommended Applications:

- Indoor/Outdoor Advertising
- Merchandising
- Film & TV
- Building Wraps

SKU	SIZE	COLOR
7521-54-MESH	54" x 40YD	White Matte



DPF 390 Flexible Translucent Substrate • 19.5 oz

Opacity: >75%

Eco-Solvent - Solvent - Latex - UV

DPF 390 is a high-quality, intermediate backlit 19.5 oz white flexible substrate. It is designed for any backlit illuminated indoor or outdoor signage. The heavy weight, durable flexible substrate is both tear and curl resistant, and it is RF weldable. It is compatible with various tensioning systems. DPF 390 has an anti-fungus and anti-wicking treatment.

Recommended Applications:

- Back Illuminated Signs
- Awnings
- LED or Fluorescent Light Boxes

SKU	SIZE	COLOR
DPF390-4'-164	4'6" x 164'	White Gloss
DPF390-6'-164	6'6" x 164'	White Gloss
DPF390-8'-164	8'6" x 164'	White Gloss
DPF390-12'-164	12'6" x 164'	White Gloss



Lumina **FDC 7501** 13 oz • 1 Year • Smooth 1 Sided Printable • 1000 Denier

Opacity: 85%

Eco-Solvent - Solvent - Latex - UV

Lumina 7501 Series is a high strength 13 oz. PVC scrim banner designed for printing general purpose signage and displays. It is a one side smooth and printable non-top coated media with a high white point that provides great printability. This product features tear, curl and fire resistance (NFPA 701, B1, M2).

Recommended Applications:

- General Purpose Signage
- Displays

SKU	SIZE	COLOR
7501-38X40-002G	38" x 40YD	White Gloss
7501-38X40-049M	38" x 40YD	White Matte
7501-54X40-002G	54" x 40YD	White Gloss
7501-54X40-049M	54" x 40YD	White Matte



You May Also Need...
Tuff Tape III™ Double Face Banner Tape
 or
PowerTape™ Hem Reinforcing Tape
 *See more information on page 104



Lumina FDC 7504 13 oz • 1 Year • Smooth 1 Sided Printable • 500 Denier

Opacity: 85%

Eco-Solvent - Solvent - Latex - UV

Lumina 7504 Series is a 13 oz. PVC scrim banner designed for printing general purpose signage and displays. It is a one side smooth and printable non-top coated media with a high white point that provides great printability. This product features tear, curl and fire resistance (NFPA 701, B1, M2).

Recommended Use:

- General Purpose Signage
- Displays

SKU	SIZE	COLOR
7504-30X40-002G	30" x 40YD	White Gloss
7504-30X40-049M	30" x 40YD	White Matte
7504-38X40-002G	38" x 40YD	White Gloss
7504-38X40-049M	38" x 40YD	White Matte
7504-54X40-002G	54" x 40YD	White Gloss
7504-54X40-049M	54" x 40YD	White Matte



Lumina FDC 7508 18 oz • 1 Year • Smooth 2 Sided Printable • 1000 Denier

Blackout - 100%

Eco-Solvent - Solvent - Latex - UV

Lumina 7508 Series is a heavy weight PVC scrim banner designed for printing large scale signage and displays. It is a two side smooth and printable non-top coated media with a blackout layer that provides opacity and obstructs light. This product features tear, curl and fire resistance (NFPA 701, B1, M2).

Recommended Use:

- General Purpose Signage
- Displays

SKU	SIZE	COLOR
7508-38X40-049M	38" x 40YD	White Matte
7508-54X40-049M	54" x 40YD	White Matte

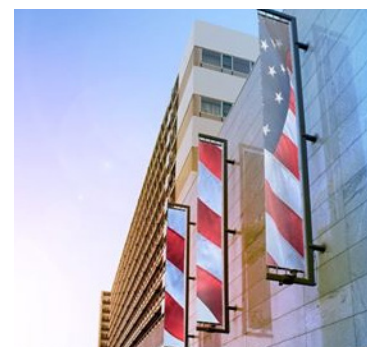

Lumina FDC 7604 13 oz • 1 Year • Super Smooth 1 Sided Printable

Blackout - 100%

Eco-Solvent - Solvent - UV

Lumina 7604 Series is a scrimless non-curling 13 oz. PVC banner designed for printing pop-up or roll-up displays. It is a super smooth one side printable non-top coated media with a grey polyester back that provides opacity and obstructs light.

Recommended Use:

- Pop Up Displays
- Roll Up Displays

SKU	SIZE	COLOR
7604-38X40-049M	38" x 40YD	White Matte
7604-54X40-049M	54" x 40YD	White Matte



Products For All Your Banner Needs...

Retractable and X-Style Banner
Stands, Grommets, Hand Press
and more!

*See more information on pages 79-80



Siser ColorPrint Easy 3.2 mil • PU Composition with Polyester Backing and White Base

Eco-Solvent - Solvent

ColorPrint Easy is the easiest weeding print and cut material ever! Compatible with eco-solvent and solvent based printers/cutters ColorPrint Easy is just what the name says- EASY! Simply print and cut your design, weed the excess with ease, and mask. ColorPrint Easy applies at only 300° F, which gives you the ability to apply to special materials that require a lower application temperature.

Recommended Application:

- Cotton
- Polyester
- Poly/Cotton Blends
- Leather
- Lycra®/spandex

SKU	SIZE	COLOR
CPEZ205001-5Y	20" x 5YD	White Semi-Gloss
CPEZ205001-10Y	20" x 10YD	White Semi-Gloss
CPEZ205001-25Y	20" x 25YD	White Semi-Gloss
CPEZ2955001-10Y	29.5" x 10YD	White Semi-Gloss



Siser ColorPrint PU 2.8 mil • PU composition with Polyester Backing and White Base

Eco-Solvent - Solvent - Latex

ColorPrint PU is a thin & stretchable print and cut material. Looking to create stretchable full-color graphics from your Eco-Solvent or Solvent based printer/cutter? ColorPrint™ PU is the answer to your needs! It's thin enough to provide a great hand and stretchable enough for most performance wear. ColorPrint™ PU is great because it doesn't require any dry time before masking.

Recommended Application:

- 100% Cotton
- 100% Polyester
- Poly/Cotton Blends
- Lycra®/Spandex
- Leather



Siser ColorPrint Sublithin 4.3 mil • Print & Cut for Materials for Sublimated Sports Garments

Eco-Solvent - Solvent

Standard print and cut material isn't formulated for use on sublimated jerseys. If you apply a regular printable polyurethane vinyl onto a sublimated garment, you'll get what's called "dye migration". Dye migration is when the sublimation inks bleed through the vinyl, causing your designs to look muddy or splotchy. ColorPrint Sublithin is specially formulated to work with most eco-solvent and solvent based inks and printers to block this dye migration and keep your graphics looking sharp on any kind of sublimated polyester garment! Great for all polyester motocross, soccer and hockey jerseys with full sublimation.

Recommended Application:

- 100% Cotton
- 100% Polyester
- Poly/Cotton Blends
- Sublimated Polyester



ORAFOL Oralite 5600 5.0 mil • 7 year • Fleet Engineer Grade Digitally Printable Reflective Film

Clear Solvent Based Permanent Adhesive

Eco-Solvent - Solvent - UV - Latex

Oralite 5600 is flexible, printable reflective film and is the perfect choice for emergency vehicle graphics and other applications where a durable, conformable and removable* reflective film is required. Solvent inkjet and thermal-print compatible, this innovative reflective film provides endless creative options.

*Removable with heat.

Recommended Application:

- Vehicle Graphics
- Reflective Lettering
- Fleet Markings
- Decorations

SKU	SIZE
5600-15-XXX	15" x 50YD
5600-153-XXX	15" x 10YD
5600-24-XXX	24" x 50YD
5600-243-XXX	24" x 10YD
5600-30-XXX	30" x 50YD
5600-303-XXX	30" x 10YD
5600-483-XXX	48" x 10YD
5600-543-XXX	54" x 10YD



Colors & Sizes Vary
Please Call for Availability

Nikkalite 4800 Series 4.83 mil • 7 year • Printable Flexible Engineering Grade Retroreflective

Pressure Sensitive Adhesive

Eco-Solvent - Solvent - Latex

4800 Series is a product manufactured for use as fleet markings, vehicle markings, stickers, decals, etc. which can be screened with multi-colored inks that will adhere very well to this sheeting. Flexible, printable reflective film is the perfect choice for emergency vehicle graphics and other applications where a durable, conformable and removable reflective film is required.

*Removable with heat.

Recommended Application:

- Commercial Signs
- Decals
- Fleet Marking
- Vehicles

SKU	SIZE
480XXX/XXXX	15" x 10/50YD
	24" x 10/50YD
	30" x 10/50YD
	48" x 10/25/50YD



Colors & Sizes Vary
Please Call for Availability

Reflectives How does it work?

Reflective is made by mixing glass beads in the pigment of the face film. The embedded beads reflect light back toward the viewer when illuminated. Therefore retro-reflective film is also referred to as beaded reflective.

These embedded beads make retro-reflective sheeting more difficult to cut than standard PVC vinyls. **Always use a 60° blade** when cutting retroreflective sheeting. You can make it work with a 45° blade and lots of force, but that blade will be worthless when you're done.

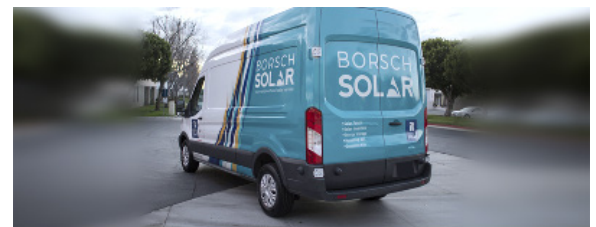

DIGITAL MEDIA

PRINTABLE REFLECTIVE FILM

Nikkalite M8500 Series 5.34 mil • 7 year • Fleet Marking Grade Retroreflective

Clear Acrylic Resin Permanent Adhesive

Eco-Solvent - Solvent - Latex

M8500 Series is a product manufactured for use as fleet marking, vehicle markings, sticker, decal, etc. which can be either digital-printed or screen-printed with multi-colored inks that will adhere very well to this sheeting. Coated with a pressure sensitive adhesive protected with an easily removable liner, this sheeting is easy to handle because of its great flexibility and is capable of giving high retro reflectivity, even when totally wet.

Recommended Application:

- Traffic Signs
- Barricades
- Delineation Devices
- Conspicuity Marking
- Decals
- Banners & Fleet Marking

SKU	SIZE
M8512/3010	30" x 10YD
M8512/3050	30" x 50YD
R8512/4810	48" x 10YD
R8512/4850	48" x 50YD



DPF 2400 5.0 mil • 7 year • Fleet Grade Digitally Printable Reflective Film

Clear Solvent Based Permanent Adhesive

Eco-Solvent - Solvent - UV

DPF 2400 is a 5-mil (125 micron) printable reflective vinyl film with high initial tack and permanent pressure-sensitive adhesive. The film conforms well to both flat and irregular surfaces when processed and applied according to Arlon recommendations. Removable with heat. DPF 2400 meets or exceeds the following standards for motor vehicles: ISO 7591-1982, DOT FP-85 - Section 718, Federal Spec. L-S-300C, and ASTM-D 4956-89, Spec. Type 1, Class 1.

Recommended Application:

- Vehicle Graphics
- Decals
- Fleet Markings

SKU	SIZE	COLOR
2400-483-222	48.5" x 10YD	White
2400-4815-222	48.5" x 50YD	White



ORAFOL Oralite 5650RA 4.3-5.5 mil • 7 year • Fleet Engineer Grade Printable Reflective Film

Clear Solvent Based Repositionable Permanent Low Initial Tack Adhesive

Eco-Solvent - Solvent - UV - Latex

Oralite 5650RA is a premium reflective film engineered specifically for challenging fleet applications. These reflective films reflect light in low-light and night-time applications and are generally used in municipal signage. Oralite 5650RA is a 5.5 mil film that's compatible with digital solvent and eco-solvent printers, and produces sharp crisp images suitable for commercial vehicle wraps and digitally printed municipal fleet graphics for police, fire, and other emergency vehicles. Application is made easier by the use of ORACAL's Rapid Air air egress liner which allows trapped air to escape during installation.

Recommended Application:

- Fleet Applications

SKU	SIZE
5650RA-30-G	30" x 50YD
5650RA-303-G	30" x 10YD
5650RA-48-G	48" x 50YD
5650RA-483-G	48" x 10YD
5650RA-54-G	54" x 50YD
5650RA-543-G	54" x 10YD





GFCVM 15 mil • Artist Stretch Canvas, Acid Free, Polyester/Cotton Blend

Eco-Solvent - Solvent - Latex

GFCVM is a 15 mil acid free, matte finish, polyester/cotton blend, artist stretch inkjet canvas with a special coating, which produces superior color gamut and resolution. Designed for high volume production and stretching applications such as photos/portraits, fine art reproductions, photo displays, maps & banners.



Recommended Applications:

- Fine Art Reproduction
- Museum Art
- Portrait
- Banner

SKU	SIZE	COLOR
GFCVM-30	30" x 40'	White Matte



Helpful Tip!

Using white cotton gloves while handling digital media and overlaminates will protect graphics from fingerprints, oils & moisture.

SKU: S-7892 *See more on page 101



Stick2 7 mil • Polypropylene, Low Tack Removable, Repositionable & Re-Apply

Water Based Repositionable Removable Low Tack Adhesive

Eco-Solvent - Solvent - Latex - Aqueous

Stick2 is a 7 mil repositionable banner with a low tack, pressure sensitive adhesive that is repositionable, removable, and may be reapplied to some surfaces. Has a universal coating that is compatible with most water-based thermal as well as solvent and eco-solvent wide format printers. Can be used indoors and outdoors for both short and long-term signage.



Recommended Applications:

- Posters
- Displays
- Window & Wall Coverings
- Trade Show

SKU	SIZE	COLOR
STICK2-36	36" x 100'	White Matte

Helpful Tip!

Be very cautious when applying vinyl films to flat finish latex painted surfaces. Heavily tinted latex paints contain surfactants (soap-like chemicals) that leach onto surfaces throughout its life, causing adhesive failure. Latex paints also contain plasticizers which can migrate to the adhesives in many pressure sensitive films causing failure. For exterior vinyl applications over a painted surface, we recommend the use of oil-based gloss enamel, or acrylic gloss enamel coatings. For interior vinyl applications over latex painted surfaces, we would recommend an eggshell or satin finish. Surfaces which have been recently painted, always allow at least 3 weeks curing time.

COMPUTER CUT VINYL

HIGH PERFORMANCE



2100/2200 Series 2 mil • 8 Year • High Performance High Gloss Cast Vinyl

2100/2200 Series is a 2-mil cast film is extra formable, thereby providing exceptional conformability, even on deep recesses and channel constructions on vans. The advanced clear permanent adhesive system is designed to perform well on a wide variety of substrates including rigid sign faces, banners, and painted metal. With outdoor durability up to 10 years, it withstands adverse climate and environmental conditions.

Recommended Applications:

- Rigid Sign Surfaces • Banners • Painted Metal • Vehicle Lettering



	39 Burgundy Metallic		67 Primrose Yellow		18 Olympic Blue		75 Lavender		02 White
	12 Burgundy		79 Kiwi		166 Periwinkle		58 Dark Magenta		00 Clear
	01 Red		69 Apple Green		32 Azure Blue		56 Hot Pink		26 Oyster
	42 Cardinal Red		61 Kelly Green		250 Intense Blue		76 Magenta		68 Beige
	60 Bright Cardinal Red		106 Medium Green		37 Medium Blue Metallic		03 Black		120 Pearl
	221 Geranium		24 Dark Green		05 Blue		40 Matte Black		27 Fawn
	14 Tomato Red		86 Forest Green		17 Sapphire Blue		23 Charcoal Metallic		59 Imitation Gold
	223 Peacock Red		230 Bottle Green		66 Medium Blue		52 Dark Gray		280 Terra Cotta
	220 Perfect Match Red		53 Dark Bahama Blue		30 Dark Blue Metallic		21 Smoke Metallic		04 Gold Metallic
	73 Poppy		71 Teal		93 Light Navy		50 Medium Gray		85 Cocoa
	96 Tangerine		89 Aqua Blue		65 Midnight Blue		80 Graphite		08 Brown
	83 Bright Orange		87 Aqua Green		11 Dark Blue		28 Dove Gray		
	97 Light Orange		51 Aruba Blue		99 Bright Purple		81 Titanium		
	165 Chrome Yellow		92 Wedgewood Blue		62 Purple		07 Silver Metallic		
	06 Yellow		31 Ocean Blue		74 Royal Purple		70 Palm Oyster Gray		

**Actual colors may vary slightly from examples shown due to limitations in the printing process.*

ORAFOL[®] Oracal 751 2 mil • 10 Year • High Gloss Premium Cast Opaque Vinyl

751 is a 2-mil, high performance PVC film with excellent dimensional stability and has permanent clear adhesive.

*Available in 79 vivid colors plus transparent, matte white and matte black.

Recommended Application:

• Rigid Sign Surfaces • Painted Metal • High Quality **Nikkalite** & Fleet Graphics



026 Purple Red	030 Dark Red	031 Red	027 Tomato Red	028 Cardinal Red	325 Middle Red	324 Blood Red	032 Light Red	326 Signal Red	047 Orange Red
033 Red Orange	034 Orange	035 Pastel Orange	020 Golden Yellow	019 Signal Yellow	211 Sun Yellow	209 Maize Yellow	021 Yellow	022 Light Yellow	025 Brimstone Yellow
063 Lime-Tree Green	064 Yellow Green	062 Light Green	068 Grass Green	061 Green	617 Emerald	078 Foliage Green	060 Dark Green	607 Turquoise Green	608 Petrol
066 Turquoise Blue	054 Turquoise	055 Mint	056 Ice Blue	053 Light Blue	517 Euro Blue	052 Azure Blue	051 Gentian Blue	067 Blue	536 Middle Blue
86 Brilliant Blue	049 King Blue	065 Cobalt Blue	537 Deep Blue	058 Ultramarine Blue	050 Dark Blue	057 Traffic Blue	518 Steel Blue	532 Black Blue	048 Bordeaux
040 Violet	403 Light Violet	043 Lavender	042 Lilac	041 Pink	077 Telemagenta	044 Magenta	045 Soft Pink	080 Brown	079 Red Brown
083 Nut Brown	081 Light Brown	023 Cream	018 Light Ivory	720 Komatsu Grey	073 Dark Grey	713 Iron Grey	071 Grey	721 Slate Grey	076 Telegrey
074 Middle Grey	072 Light Grey	010 White	090 Silver Grey	930 Gold	824 Imitation Gold	093 Anthracite	070 Black	000 Clear	

*Actual colors may vary slightly from examples shown due to limitations in the printing process.

COMPUTER CUT VINYL

INTERMEDIATE



ARLON

4500/4550 CalPlus 3 mil • 6 Year • Satin Intermediate Calendered Opaque Vinyl

4500/4550 CalPlus is a 3-mil calendered film with permanent clear adhesive that is ideal for a wide variety of applications. This product comes in 28 eye-catching colors and has an outdoor durability of up to 6 years.

Recommended Application:

- Interior/Exterior Graphics • Banners



	168 Daisy Yellow		160 Bright Cardinal Red		137 Blueberry		108 Brown		134 Cloud Gray
	116 Lemon Yellow		173 Dark Red		193 Viking Blue		180 Terra Cotta		149 Light Gray
	106 Yellow		112 Burgundy		130 Dark Blue		159 Imitation Gold		103 Black
	119 Light Orange		110 Purple		171 Teal		182 Beige		102 White
	109 Orange		176 Dark Purple		164 Spring Green		104 Gold Medal		100 Clear
	114 Tomato Red		118 Olympic Blue		111 Green		107 Silver		
	133 Fire Red		198 Medium Blue		135 Imperial Green		150 Dark Gray		
	101 Red		105 Blue		186 Forest Green		140 Gray		

**Actual colors may vary slightly from examples shown due to limitations in the printing process.*

Helpful Tip!

It takes approximately three to four weeks for most paints to cure completely. The paint curing process is very important for **successful** vinyl application.



5000/5050 Series 3 mil • 6 Year • High Gloss Intermediate Vinyl

5000/5050 Series is an ultra thin 2.8-mil (70 micron) calendered film and is one of the most pliable calendered films on the market with permanent clear adhesive. The product has a high gloss finish, and is ideal for signs, graphics or displays requiring vibrant color. This new film is available in 37 bright colors, provides excellent cutting and weeding for improved productivity and has an outdoor durability rating of up to 6 years.

Recommended Application:

- Interior/Exterior Graphics • Banners



68
Daisy
Yellow



31
Rose



71
Teal



04
Gold
Medal



06
Yellow



10
Purple



60
Spring
Green



07
Silver



09
Orange



36
Mission
Blue



11
Green



34
Cloud
Gray



33
Fire
Red



05
Blue



61
Medium
Green



03
Black



01
Red



37
Blueberry



35
Imperial
Green



40
Matte
Black



12
Burgundy



50
Royal
Blue



08
Brown



02
White



32
Cotton
Candy



30
Dark
Blue

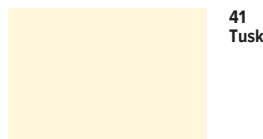

41
Tusk



49
Matte
White

**Actual colors may vary slightly from examples shown due to limitations in the printing process.*

Helpful Tip!

Vinyl & digital rolls are designed to be stored in temperatures between 64°F - 72°F.

COMPUTER CUT VINYL

INTERMEDIATE

ORAFOL® **Oracal 651** 2.5 mil • 6 Year • Intermediate Calendered Vinyl Film

651 is a 2.5-mil, intermediate calendered PVC film with excellent dimensional stability and has clear solvent based permanent adhesive.

*Available in 60 vivid colors plus transparent, matte white and matte black.

Recommended Application:

- Medium-Term Indoor and Outdoor Lettering • Marking • Decoration



000 Transparent	010 White	020 Golden Yellow	019 Signal Yellow	021 Yellow	022 Light Yellow	025 Brimstone Yellow	026 Purple Red
312 Burgundy	030 Dark Red	031 Red	032 Light Red	047 Orange Red	036 Light Orange	035 Pastel Orange	404 Purple
040 Violet	043 Lavender	042 Lilac	041 Pink	045 Soft Pink	562 Deep Sea Blue	518 Steel Blue	050 Dark Blue
085 Cobalt Blue	049 King Blue	086 Brilliant Blue	067 Blue	057 Traffic Blue	051 Gentian Blue	028 Gentian	052 Azure Blue
084 Sky Blue	053 Light Blue	056 Ice Blue	066 Turquoise Blue	054 Turquoise	055 Mint	060 Dark Green	613 Forest Green
061 Green	068 Grass Green	062 Light Green	064 Yellow Green	063 Lime-Tree Green	080 Brown	083 Nut Brown	081 Light Brown
082 Beige	023 Cream	070 Black	073 Dark Grey	071 Grey	076 Telegrey	074 Middle Grey	072 Light Grey
090 Silver Grey	091 Gold	092 Copper					

**Actual colors may vary slightly from examples shown due to limitations in the printing process.*

Nikkalite® 48000 Series 6.2 mil • 7 Year • Flexible Engineer Grade Reflective Vinyl

Nikkalite® Brand 48000 Series Flexible Engineer Grade (ELG) retro-reflective sheeting is a product manufactured for use as fleet markings, vehicle markings, stickers, decals, etc. which can be screened with multi-colored inks that will adhere very well to this sheeting. Coated with a pressure sensitive adhesive protected with an easily removable liner, this white 6.2 mil sheeting is easy to handle because of its great flexibility and is capable of giving high retro-reflectivity.

Recommended Application:

- Commercial Signage • Stickers • Decals • Flat Surfaces • Vehicles



	48077P Orange		48004P Yellow		48012P White
	48008P Green		48046 Sky Blue		48006P Blue
	48005 Red		48035P Ruby Red		48025P Dark Red
	48010P Gold		48009P Brown		48003P Black









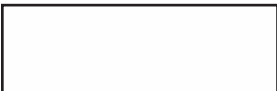

ORAFOL® Oralite 5600 5 mil • 7 Year • Fleet Engineer Grade Reflective Vinyl

5600 is a 5 mil, engineer grade, cast PVC, digitally printable reflective film. It is available in 14 high impact colors. Oracal 5600 Reflective comes with a clear solvent-based permanent adhesive and is good for up to 7 years.

Recommended Application:

- Medium-Term Indoor and Outdoor Lettering • Marking • Decoration

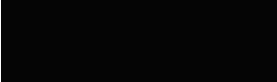

	010 White		020 Yellow		030 Red
	213 Lemon Yellow		035 Orange		364 Ruby Red
	054 Turquoise		050 Blue		060 Green
	070 Black		091 Gold		

**Actual colors may vary slightly from examples shown due to limitations in the printing process.*



SF 100 White Paint Mask 3.2 mil • Calendered Film Clear Removable Acrylic

SF 100 Series paint masks are flexible calendered vinyl with removable adhesive, which will cleanly remove from most OEM surfaces up to 1 year, when removed promptly after painting and curing cycles.

Recommended Application:

- Thermal Die-Cutting
- Drum Roller Sign-Cut
- Steel Rule Die-Cutting
- Sign Stencils
- OEM Stencil
- Removable Letters
- Eradication

SKU	SIZE
A1828-S-A	15" x 10 YD - Perforated
A1828-S-C	15" x 50 YD - Perforated
A1828-S-K	24" x 10 YD - Non-Perforated
A1828-S-M	24" x 50 YD - Non-Perforated
A1828-S-E	30" x 10 YD - Perforated
A1828-S-Q	30" x 50 YD - Non-Perforated
A1828-S-U	48" x 50 YD - Non-Perforated



Lumina 7262 Static Cling 7.5 mil • 3 Months • Calendered Gloss Media

Blockout - No Adhesive - N/A

Eco-Solvent - Solvent - Latex - UV - Screen - Thermal

Lumina 7262 Static Cling print media is a calendered gloss static cling vinyl film designed for printing window graphics & decals. 40°F minimum application temp. Interior or smooth extension & non-perforated.

Recommended Use:

- Glass Application
- Decals

SKU	SIZE	COLOR
7262-WHT-1508	15" x 25	Gloss White
7262-CLR-1508	15" x 25	Gloss Clear
7262-WHT-3008	30" x 25	Gloss White
7262-CLR-3008	30" x 25	Gloss Clear



Lumina 4305 Dry Erase 4.0 mil • 3 Months • Calendered Clear Matte Media

Lumina 4305 Series Promotional Dry Erase Vinyl Film - This is a calendered vinyl film specially formulated for interior use with dry erase type materials. The product can be written on repeatedly then wiped clean with dry erase cleaning fluid. This is for interior use only and not digital print compatible.

Recommended Use:

- Vinyl
- Wall
- Sheeting
- A-Frames

SKU	SIZE	COLOR
4305-243-00	24" x 10YD	Matte Clear
4305-303-00	30" x 10YD	Matte Clear

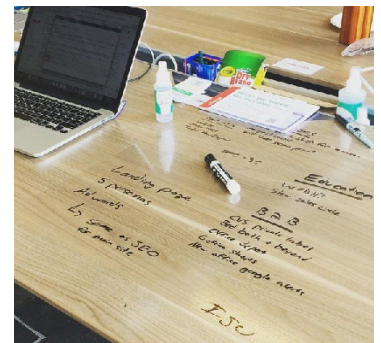

Helpful Tip!

Apply dry erase to any printed media or sign substrate to create your own message center.

ORAFOL® Oracal 8510 3mil • 7 Year • Translucent Etched Glass

8510 gives an amazing etched look without having to use a sand blaster or etching cream. Ideal for decorative design of shop window or glass door. Wet application is recommended. Create beautiful window graphics Indoor or outdoors!

Recommended Application:

- Shop Windows • Glass Doors



Fine Silver

**Actual colors may vary slightly from examples shown due to limitations in the printing process.*

SKU	SIZE
8510-153-90	15" x 10YD
8510-243-90	24" x 10YD
8510-24-90	24" x 50YD
8510-303NP-90	30" x 10YD
8510-30-90	30" x 50YD
8510-483-90	48" x 10YD



Helpful Tip!
Isopropyl alcohol is ideal for cleaning glass surfaces prior to installation of etched glass vinyls.

ORAFOL® Oracal 6510 4 mil • 1 Year • Fluorescent Cast Vinyl Film

6510 is a 4-mil, fluorescent cast PVC film with clear solvent based permanent adhesive and has high visibility when in all daylight conditions. Especially effective in twilight and poor visibility conditions.

Recommended Application:

- Vehicle and Bus Advertising • POP Displays • Labels • Decals • Retail



029 Yellow Fluorescent



069 Green Fluorescent



037 Orange Fluorescent



039 Red Fluorescent



357 Orange Red Fluorescent



046 Pink Fluorescent

SKU	AVAILABLE STRIPE SIZES	
	15" x 10YD	24" x 10YD
Yellow	✓	✓
Green	✓	✓
Orange	✓	✓
Red	✓	✓
Pink	✓	✓
Orange Red	✓	✓



**Actual colors may vary slightly from examples shown due to limitations in the printing process.*

ORAFOL **Oracal 352** 1 mil • 1-2 Year • Thermal Print Polyester

352 is a 1-mil metallized polyester film with excellent dimensional stability. Optimized for screen and thermal print applications, this printable polyester is designed for weather-resistant decorative labels, name, and technical plates, decorations, moldings, and lettering. 901 Chrome and 912 Gold are 2-mil PETP films. Chrome films have a 2 year outdoor rating; gold-colored film has a one year outdoor durability.

*Two-sided gold finish features 1-year outdoor durability



Recommended Application:

- Window Graphics • Mirrors • Partitions • Glass or Clear Substrates • Interior & Exterior Applications

	Gold	SKU	DESCRIPTION	SIZE
		352-153-911	Double Sided	15" x 10YD
		352-15-911	Double Sided	15" x 50YD

SignGold **Quick Sign Gold** 1 mil • 10 • Year 22kt Sign Gold Vinyl Film

Quick 22KT Sign Gold is used around the world to create beautiful graphics indoors and out. 22KT Sign Gold is available in 1" stripe, 15" and 24" wide rolls of non-fading 22KT gold vinyl with a permanent pressure sensitive adhesive for use on CAD/CAM sign making systems. Quick 22KT Sign Gold is guaranteed for 10 year outdoor life.



Recommended Application:

- CAD/CAM Sign Making Systems

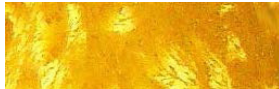
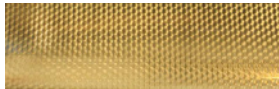
	SKU	AVAILABLE SIZES			
		15" x 2YD	15" x 5YD	24" x 2YD	24" x 5YD
 Florentine Swirl	Gold Florentine Swirl	✓	✓	✓	
	Gold Satin Surface	✓	✓	✓	
	Gold Small Engine Turn	✓	✓		
 Small Engine Turn	Gold Large Engine Turn	✓	✓	✓	✓
	Gold XL Engine Turn	✓	✓	✓	✓

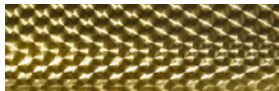
	SKU	AVAILABLE STRIPE SIZES		
		¼" x 50'	½" x 50'	1" x 50'
 Large Engine Turn	Gold Florentine Swirl	✓	✓	
	Gold Satin Surface	✓		✓
	Gold Large Engine Turn		✓	✓

 XL Engine Turn	SKU	AVAILABLE STRIPE SIZES		
		¼" x 50'	½" x 50'	1" x 50'
		Gold Large Engine Turn		✓

Did You Know?

Using appropriate plotter & printer blades will ensure precise cutting & weeding of vinyls.

- Use **45°** Degree blade for High Performance and Intermediate Vinyl
- Use **60°** Degree blade for Reflective, Metalized Polyester, SignGold & Sandblast Stencil.



ORAFOL **Oracal 383** 3.5 mil • 5 Year • Ultraleaf Cast Vinyl Film Perforated/Non-Perforated

383 is a 3.5 mil, 5-year cast film with clear solvent based permanent adhesive and is a cost-effective alternative to 24-carat gold or silver leaf film. ORACAL 383 features a smooth, printable surface and a three-dimensional visual texture. The durable dimensional stability of this film makes it ideal for lettering, marking, decoration of vehicles, windows, & signs requiring longer-term outdoor durability.



Recommended Application:

- Window Graphics • Mirrors • Partitions • Glass or Clear Substrates
- Interior & Exterior Applications

	SKU	AVAILABLE SIZES	
		15" x 10YD	24" x 10YD
 Chrome	Chrome Ultra Leaf	✓	✓
 Gold	Chrome Ultra Leaf	✓	



R.Tape Vinyl Efx 1 mil • 3 Year • Decorative Printable Metallized Vinyl

R.tape Vinyl efx is metallized special effects films have always been popular for decorating race cars, billboards, and short-term promotional signage. Vinyl Efx colors are through-and-through the vinyl - NOT laminated or top coated. Unlike cold-embossed polyesters, our fade-resistant films are hot-embossed, which produces deeper, better defined patterns. The Vinyl Efx Outdoor Durable Series, which provides up to three years of outdoor life, is comprised of a variety of cost-effective simulated metal, light-diffracting and 3-D patterns, designed for long-term outdoor signage. For demanding applications such as truck and boat graphics, the Vinyl Efx Durable Series films provide a superior alternative to the expensive simulated gold-leaf films.

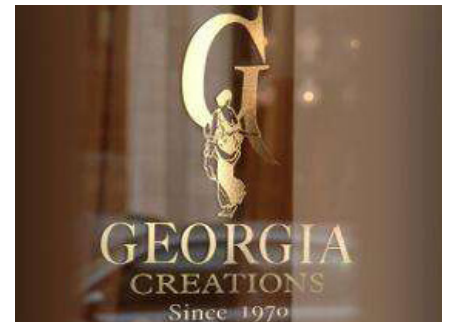

Recommended Application:

- POP posters • Displays • Vehicle Graphics • Window Graphics • Tradeshow Graphics • Boat

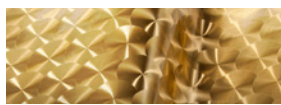

Gold 1" Large Engine Turn



Gold Hammered Leaf



Gold Florentine



Gold Brushed



Gold Smooth Mirror



Silver Diamond Plated

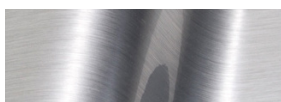

Silver Brushed



Silver Smooth Mirror

SKU	AVAILABLE SIZES	
	15" x 10YD	24" x 10YD
Gold 1" Large Engine Turn	✓	✓
Gold Florentine	✓	✓
Gold Hammered Leaf	✓	✓
Gold Brushed	✓	✓
Gold Smooth Mirror	✓	✓
Silver Diamond Plate	✓	✓
Silver Brushed	✓	✓
Silver Smooth Mirror	✓	✓

**Actual colors may vary slightly from examples shown due to limitations in the printing process.*

Helpful Tip!

Using a 60° Blade on metallized vinyl will ensure a cleaner cut for easier weeding.

COMPUTER CUT VINYL TRANSLUCENT



2500 Series 2 mil • 7 Year • Premium Cast Translucent Gloss Vinyl Film

2500 Series is a premium 2-mil cast vinyl with permanent clear adhesive is designed specifically for back or internally illuminated signage. Now with added colors, Series 2500 is available in 58 standard colors, the palette is endless with Arlon's custom color capabilities. Batch-to-batch consistency ensures the integrity of regional and national programs. Series 2500 is compatible with a wide variety of rigid and flexible substrates.

Recommended Application:

- Interior/Exterior Graphics • Banners



	2037 Yellow		43 Light Tomato Red		63 Rust Brown		557 Imperial Blue		3227 Bright Green
	15 Yellow		83 Regal Red		59 Dark Brown		2940 Blue		26 Green
	1090 Yellow		33 Red		69 Duranodic		3238 European Blue		4028 Green
	525 Bright Yellow		2885 Fox Red		22 Black		36 Dark Blue		76 Holy Green
	125 Golden Yellow		2510 Red		57 Olympic Blue		2114 Blue		2108 Green
	25 Sunflower		75 Dark Red		337 Process Blue		87 Royal Blue		112 Olive Green
	169 Marigold		253 Cardinal Red		127 Intense Blue		236 Turquoise		51 Silver Gray
	84 Tangerine		2283 Red		2930 Blue		246 Teal		71 Shadow Gray
	2119 Orange		49 Burgundy		67 Bright Blue		307 Dark Aqua		20 White
	44 Orange		78 Vivid Rose		2051 Blue		106 Brilliant Green		05 Ivory
	2662 Red		133 Raspberry		97 Bristol Blue		2586 Green		121 Silver Metallic
	415 Fire Red		128 Plum		157 Sultan Blue		146 Light Kelly Green		131 Gold Metallic
	143 Poppy Red		2856 Purple		2870 Blue		156 Vivid Green		

**Actual colors may vary slightly from examples shown due to limitations in the printing process.*

ORAFOL **Oracal 8500** 3 mil • 7 Year • High Performance PVC Vinyl Film

8500 meets the demands of internally illuminated signage with a 7-year durability and unbeatable color consistency from roll-to-roll. The silk-matte finish is perfect for reducing undesired reflection and the workability will change the way you think about translucent film. Series 8500 Film has clear solvent based adhesive and has been designed for producing high quality illuminated signs on rigid & thermo-formed surfaces, & has been approved for prethermo-forming.



Recommended Application:

- Interior/Exterior Graphics • Glass • Backlit Signs

010 White	025 Yellow Brimstone	021 Yellow	013 Zinc Yellow	020 Golden Yellow	207 Ochre Yellow	034 Orange	330 Fox Red	323 Red Coral	032 Light Red	329 Carnation Red
016 Crimson	031 Red	017 Cherry Red	030 Dark Red	085 Pale Pink	413 Light Pink	041 Pink	008 Heather Red	040 Violet	403 Light Violet	012 Lilac
527 Pastel Blue	053 Light Blue	052 Azure Blue	051 Gentian Blue	528 Gray Blue	005 Middle Blue	006 Intensive Blue	049 King Blue	542 Caribic Blue	065 Cobalt Blue	007 Dark Blue
541 Dark Turquoise	066 Turquoise Blue	054 Turquoise	062 Light Green	063 Lime-Tree Green	009 Middle Green	614 Reed Green	068 Grass Green	618 Dragon Green	087 Emerald	060 Dark Green
070 Black	074 Middle Gray	076 Telegay	072 Light Gray	805 Ivory	011 Pale Brown	081 Light Brown	088 Coffee Brown	090 Silver Gray	031 Gold	



**Actual colors may vary slightly from examples shown due to limitations in the printing process.*

Helpful Tip!

Black translucent vinyl is actually opaque which will not allow light to penetrate it.

COMPUTER CUT VINYL METALLICS

ORAFOL Oracal 951M 2 mil • 3 Year • Premium PVC Cast Vinyl Film

Developed to create eye-catching lettering, marking, and decorative elements that meet the most extreme performance requirements. With its superior conformability over rivets and corrugations and unsurpassed dimensional stability, this film is ideal for premium vehicle restyling and fleet advertising applications.

Recommended Application:

- Exterior Graphics • Vehicle Wraps



368 Dark Red Metallic



367 Red Metallic



369 Red Brown Metallic



366 Red Gold Metallic



92 Copper Metallic



920 Bronze Metallic



922 Brass Metallic



923 Light Brown Metallic



921 Antique Bronze Metallic



91 Gold Metallic



925 Pale Gold Metallic



926 Pyrite Metallic



680 Steppe Green Metallic



678 Autumn Green Metallic



677 Fir Green Metallic



676 Wood Green Metallic



679 Foliage Green Metallic



673 Jade Metallic



675 Sea Green Metallic



637 Teal Metallic



199 Turquoise Metallic



194 Grey Blue Metallic



191 Green-Blue Metallic



674 Mint Metallic



681 Grey Green Metallic



195 Dove Blue Metallic



197 Azure Blue Metallic



196 Night Blue Metallic



580 Storm Blue Metallic



193 Navy Metallic



192 Deep Blue Metallic



189 Midnight Metallic



190 Moonlight Metallic



406 Violet Metallic



924 Champagne Metallic

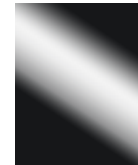

704 Black Metallic



93 Anthracite Metallic



937 Charcoal Metallic



932 Graphite Metallic



936 Silicon Metallic



934 Zinc Metallic



905 Grey Metallic



935 Grey Cast Iron Metallic



906 Silver Metallic



908 Aluminum Metallic



933 Tin Metallic



90 Silver Grey Metallic



904 Silver Lake Metallic

**Actual colors may vary slightly from examples shown due to limitations in the printing process.*

Siser EasyWeed® 3.5 mil • PU Composition with Pressure Sensitive Backing

Semi-gloss finish

EasyWeed® applies at a lower temperature than competitor material, backing can be peeled hot or cold and doesn't lift during weeding. It's also extremely durable wash after wash and uses a lower pressure setting for application. EasyWeed is thinner than others on the market and offers a one-second tack application that's great for multiple layers. EasyWeed has a pressure sensitive carrier that allows you to offer detailed designs on a wide variety of fabrics. EasyWeed can be cut with laser systems.

Recommended Application:

- 100% Cotton • 100% Polyester • Poly/Cotton Blends • Leather



						
01 White	16 Fluorescent Yellow	21 Lemon	06 Yellow	28 Sun	08 Orange	17 Fluorescent Orange
						
74 Texas Orange	72 Maroon	71 Cardinal	14 Burgundy	05 Red	55 Bright Red	84 Fluorescent Coral
						
63 Hibiscus	30 Fluorescent Raspberry	19 Fluorescent Pink	09 Pink	65 Light Pink	79 Bubble Gum	62 Lilac
						
15 Purple	04 Navy Blue	03 Royal Blue	20 Fluorescent Blue	10 Sky Blue	61 Pale Blue	83 Powder Blue
						
27 Turquoise	18 Fluorescent Green	78 Lime	64 Green Apple	07 Green	24 Dark Green	80 Charcoal
						
02 Black	22 Grey	13 Silver	12 Gold	70 Vegas Gold	11 Brown	29 Cream

**Actual colors may vary slightly from examples shown due to limitations in the printing process.*

COMPUTER CUT THERMAL VINYL

Siser EasyWeed® Extra 3.5 mil • PU Composition with Pressure Sensitive Backing

Semi-gloss finish

EasyWeed® Extra is on a pressure-sensitive carrier so you can cut detailed logos and weed them effortlessly. The ability to peel your designs HOT or COLD offers you the option to peel each item as it comes off the press, or to stack all applied garments and peel after the job is complete. Looking to provide multi-color designs for your customers? EasyWeed Extra – with its semi-gloss finish, can be layered, extending your creativity and allowing you to say “yes” to more complicated designs. EasyWeed Extra can be cut with laser systems.

Recommended Application:

• 100% Cotton • 100% Polyester • Poly/Cotton Blends • Leather • Nylon



01
White



05
Red



04
Navy Blue



15
Purple

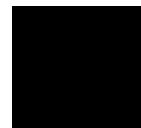

02
Black

Siser EasyWeed® Stretch 3.5 mil • PU Composition with Pressure Sensitive Backing

True matte finish

EasyWeed® Stretch by Siser delivers all the benefits of our EasyWeed heat transfer material and combines it with super stretchability to create one remarkable heat transfer material! The thinnest of any Siser material, EasyWeed Stretch has a true matte finish and a soft hand that's available in 20 popular colors, including sweet mint and coral. While EasyWeed Stretch is ideal for performance apparel, the soft hand and light weight often make it a favorite for other garment decorating. EasyWeed Stretch can be cut with laser systems.

Recommended Application:

• 100% Cotton • 100% Polyester • Poly/Cotton Blends • Leather • Lycra®/Spandex



01
White



05
Red



55
Bright Red



08
Orange



06
Yellow



28
Sun



07
Green



03
Royal Blue



04
Navy Blue



13
Silver



12
Gold



02
Black

**Actual colors may vary slightly from examples shown due to limitations in the printing process.*

Siser Glitter Vinyl 12.8 mil • PU Composition with Pressure Sensitive Backing

Glitter finish

Bling out plain designs for maximum appeal with the best **Glitter HTV** on the market! Available in over 30 vibrant colors, Glitter contains maximum sparkle without shedding any glitter flakes. Kids of all ages love the shimmer and pop, and since it's CPSIA Certified it's safe to apply on kids clothing.

Recommended Application:

- 100% Cotton • 100% Polyester • Poly/Cotton Blends • Leather

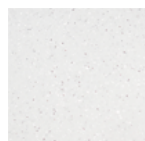

00 White

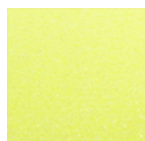

71 Neon Yellow

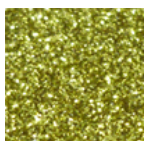

12 Gold

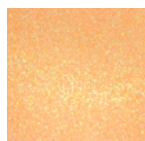

73 Neon Orange

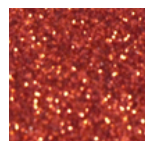

05 Red

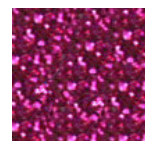

19 Hot Pink

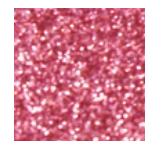

09 Blush

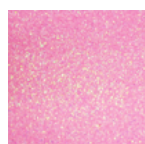

74 Neon Pink

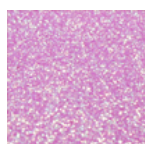

65 Translucent Pink

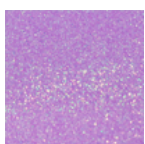

75 Neon Purple

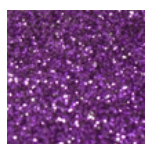

15 Purple



70 Neon Blue

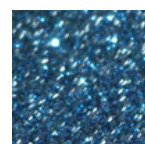

61 Blue

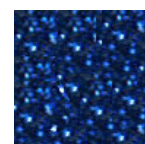

03 Royal

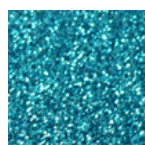

10 Aqua



07 Light Green



72 Neon Green

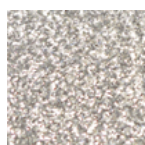

13 Silver

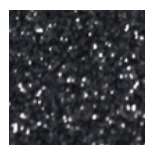

02 Black

**Actual colors may vary slightly from examples shown due to limitations in the printing process.*

Siser EasyWeed® Glow 3.5 mil • PU Composition with Pressure Sensitive Backing

Matte finish

EasyWeed® Glow is available in white and it cuts and weeds like our popular EasyWeed heat transfer vinyl. To get the glow effect, “charge” the material by exposing it to sunlight. The more light you give it, the more it glows in the dark! Great for crafters looking to create kids’ pillow cases with messages that shine at bedtime. EasyWeed Glow is also perfect for simple Halloween costumes and can be layered on other Siser materials! EasyWeed Glow can be cut with laser systems.

Recommended Application:

- 100% Cotton • 100% Polyester • Poly/Cotton Blends • Leather



Glow in the Dark

Siser **Metallic** 3.9 mil • PET Composition with Pressure Sensitive Backing

Gloss finish

This **Metallic Heat Transfer Vinyl** material is great for adding the look of metallic gold or silver to any garment. Siser Metallic gives the shiny look of a colored chrome. Please note that Metallic is a unique product and that cracking and delamination may occur after washing - **The results are not predictable.**

Recommended Application:

- 100% Cotton • 100% Polyester • Poly/Cotton Blends • Leather



44
Metallic Silver



45
Metallic Gold

Siser **Holographic** 4.3 mil • Polyester Composition with Pressure Sensitive Backing

Gloss finish

Holographic contains color changing chips that create the effect of depth and dimension. Holographic can be cut to look exactly like rhinestones, without having to go through all the extra work associated with applying rhinestone designs. Holographic can be cut with laser systems.

Recommended Application:

- 100% Cotton • 100% Polyester • Poly/Cotton Blends • Leather



01 Holographic
Crystal



13 Holographic
Silver

Siser **StripFlock**® 16.1 mil • PVC Composition with Pressure Sensitive Backing

Suede-like finish

A great alternative to embroidery, **StripFlock** gives logos a raised, textured, suede-like feel. Stripflock can be used as a base layer and covered with other materials, giving a very unique, high-end look to logos and designs. In addition, StripFlock is very opaque and has deep, rich colors that are great for animal prints and for layering on top of other materials.

Recommended Application:

- 100% Cotton • 100% Polyester • Poly/Cotton Blends • Leather

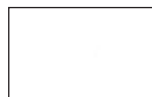

01
White



02
Black

Siser EasyWeed® Electric 3.5 mil • PU Composition with Pressure Sensitive Backing

Semi-gloss finish

EasyWeed® Electric colors are vibrant with a pearlescent metallic sheen. EasyWeed Electric comes on a pressure-sensitive carrier which makes cutting detailed designs and logos a breeze. EasyWeed Electric is durable wash after wash and maintains its bright color and brilliant finish. If you're looking to provide multi-color designs, EasyWeed Electric can be layered.

Recommended Application:

- 100% Cotton • 100% Polyester • Poly/Cotton Blends • Leather



32 Silver Lens



40 Gold Lens



38 Red



44 Rose Gold



75 Columbia Blue



60 Teal

Siser CADflex™ 6.8 mil • PVC Composition with Pressure Sensitive Backing

Semi-gloss finish

CADflex™ is a heat transfer vinyl with a non-stick carrier that makes it perfect for stocking up and storing athletic names, numbers, and team logos. Prepare your team sets ahead of time by cutting multiple numbers and team logos and store them for quick use. CADflex is perfect for all sports including soccer, football, baseball, softball and more!

Recommended Application:

- 100% Cotton • 100% Polyester • Poly/Cotton Blends • Leather



01 White

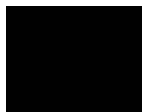

02 Black



05 Red



28 Dark Yellow



03 Royal Blue



04 Navy Blue

Siser EasyReflective® 5.5 mil • PET Composition with Pressure Sensitive Backing

Reflective finish

EasyReflective® is Siser's only reflective material with a pressure sensitive backing! This highly reflective heat transfer vinyl is constructed with glass bead technology to illuminate the darkest of conditions. EasyReflective is a truly exceptional polyurethane product due to its pressure sensitive carrier that allows you to re-stick lifting material or replace a piece that's accidentally removed. With a low application temperature and simple warm peel, EasyReflective can be applied to all kinds of garments and accessories that need to stand out in low lighting.

Recommended Application:

- 100% Cotton • 100% Polyester • Poly/Cotton Blends • Nylon (testing recommended)



Reflective Silver

Siser Heat Press

Siser heat presses are the machines you need to get the job done. The Siser Digital Clam Heat Press is ideal for letters & numbers, left chest logos or full-front designs. The Siser Digital Cap Heat Press is perfect for printing caps and hats, as well as applying labels in shirts, shorts, and bags. Whatever you need to print, Siser has heat presses that will help you get it done!

The Siser Digital Clam Press

The Siser Digital Clam Press is a great, economical heat press that works in the shop or on the go at events for on-demand printing. The Siser Digital Clam Press is easy to operate with a digital time and temperature readout and over-the-center pressure adjustment. The upper flotation platen provides a flat, even surface. Used in conjunction with a heat transfer pillow there's nothing you CAN'T print! The Siser Digital Clam Press is ideal for individuals who are just starting out in the industry, as a second press for home or the shop, or as a travel press that you take to live events like car shows, dance competitions, cheer events and more for complete on-demand heat printing and personalization!



Geo Knight & Co Inc Heat Press

Geo Knight & Co is the premier manufacturer and supplier of heat transfer press machines used for these processes. We specialize in both commercial grade manual heat transfer presses as well as industrial large format automatic equipment.

We accommodate our customers with exactly the machinery they need to transfer press graphics and other embellishments onto a wide variety of materials. We manufacture according to the highest industry standards and only implement solid casting and steel structural frame designs, coupled with state of the art controls and heaters.

Our presses have been the backbone of literally thousands upon thousands of business over the past 4 decades, providing a reliable workhorse of a product that stands up to the demands of imprinting business, manufacturing & personal use.

Swing-Away

Swing-Away presses are used for medium to heavy pressing: garments, plaques, tiles, and other materials.

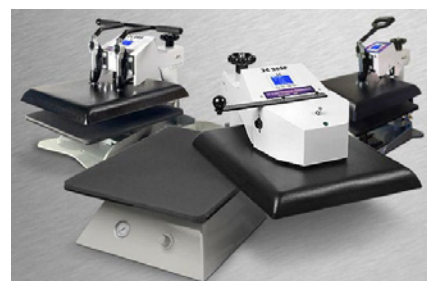

Multipurpose

Our Digital Combo swing-away heat press has a variety of heat platen attachments. This machine does it all.



Clamshell

Our clamshell style of heat press equipment meets business and manufacturing needs worldwide.

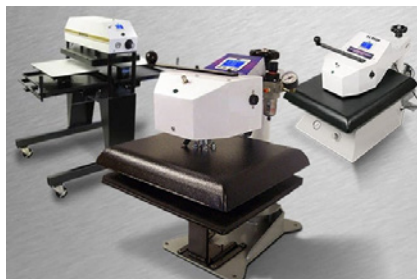

Automatic

These presses operate automatically, relieving the operator of major tasks of manual machines.

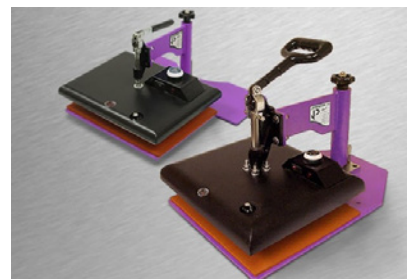

Light Use

The JetPress machines are a heavy duty line of low-cost, economical swing away heat presses.

Roland Eco-Solvent™ Printers

SOLJET® EJ-640

High-Volume Large-Format Printer - Size: 64"



- Dual eight channel piezo inkjet heads with 180 nozzles per channel
- Photographic image quality in all print modes, including high speed
- EJ INK for fast dry times and lower running costs
- Included media take-up system handles rolls up to 110 lbs.

VersaEXPRESS® RF-640

Professional Large-Format Printer - Size: 64"



- Advanced imaging technology with photorealistic imaging at 1440 dpi
- Roland Printer Assist enables printer control from iPad
- Included media take-up system handles rolls up to 110 lbs.

Eco-Solvent™ Printers & Plotters/Cutters

TrueVIS™ VG2 Series

Professional Large-Format Printer - Size: 54" & 64"



- New TR2 ink offers unequalled color reproduction & expanded color gamut
- Elevated print/cut accuracy & smart new automated pinch rollers
- 4-color, 7-color or 8-color configurations— including new Orange ink options
- *Take up unit is included with VG2 models.*

TrueVIS™ SG2 Series

Performance Printer/Cutter - Size: 30", 54" & 64"



- Featuring new TR2 ink for a wider color gamut with brilliantly vivid print output at a very low ink cost per sq/ft
- Offering smart new print/cut features that include automated pinch rollers
- *Take up unit is not included with SG2 models.*

VersaSTUDIO® BN-20

Desktop Inkjet Printer/Cutter - Size: 20"



- Handles a wide variety of jobs on a full spectrum of media
- Includes Metallic Silver and White ink options
- Combine with a heat press to create custom apparel

We stock a wide range of consumable Roland parts.

Please call for availability & pricing!

Roland Plotters/Cutters

CAMM-1 GS-24

Desktop Cutter
Size - 24"



- Efficiently cuts up to 19.7 in/s (500 mm/s)
- Powerful down force of up to 350 gf so you can cut thick materials
- Up to 10x overlap cutting for cutting thicker materials with precision
- Stand included with purchase that holds roll media and offers smooth set up

CAMM-1 GR Series

Professional Cutter
Size - 54" & 64"



- Designed for faster cutting at 58.5 in/s (1,485 mm/s) and an increased down force of 600 gf
- Features 2 blade positions with the front position designed for perforated cutting
- Roland Quadralign™ optical registration system automatically recognizes printer crop marks on printed media

GRAPHTEC Plotters/Cutters

FC8600 Series

Available in 5 Widths



Graphtec FC8600 series high-performance roll feed cutting plotter is an industry leader for sign makers, graphic artists, and other related users. The FC8600 series features a maximum cutting speed of 58.5 in/sec, 4.0 G maximum acceleration, and 20 to 600 g selectable cutting forces, allowing users to process diamond grade, high-intensity reflective film, sandblast resist rubber, automotive window & paint protection films, self-adhesive vinyl, among other media types.

CE6000 Plus Series

Available in 3 Widths



Graphtec CE6000 Plus Series - the built-in front control panel provides complete parameter control including eight preset cutting conditions, as well as advanced features like tangential control mode, down force offset, pen up speed, blade wear monitoring and more. With maximum force of the 4.41 N (450 gf) and a maximum speed of 1000 mm/s, it enable to cut various media with high productivity. With a 25 pin RS-232C or the High Speed USB 2.0 control interface, a newer, larger LCD screen, managing your cutting jobs is simpler than ever!

RS Royal Sovereign Cold Roll Laminators

Entry Level Cold Roll Laminators

The practical and affordable solutions for first time operators entering the wide format lamination industry.



RSC-820CLS (32") & RSC-1401CLTW (55")

- Included stand with casters
- Release liner take-up standard feature
- Durable motor reaching up to 16 ft./min. *(RSC-1401CLTW)
*8ft./min for RSC-820CLS
- Mount substrates up to 5/8" *(RSC-1401CLTW)
*Up to 9/32" for RSC-820CLS

Traditional Level Cold Roll Laminators

Designed and engineered to provide everyday convenience to the advanced user specializing in wide format digital finishing.



RSC-1402CW & RSC-1402HW (55"), RSC-1651LS & RSC-1651LSH (65")

- Lamination speeds over 16 ft./min
- Mount substrates up to 1"
- Foot pedal, cross cutter and rear facing remote standard
- Add front feeder and rear rewinder for roll-to-roll lamination

Roland Eco-Sol Max Ink

Durability up to three years outdoors without lamination. Ink running costs as low as 16¢ per sq. ft. Quick drying time for improved production speed. Improved scratch resistance for increased durability and easy handling. Wider color gamut for reds, blues and greens. Virtually odorless and user-friendly. Aggressively adheres to a broad range of affordable media including Roland's complete line of uncoated and coated media.



SKU	SIZE	COLOR
220ESL3-CN / 440ESL3-4CN	220ml / 440ml	Process Cyan
220ESL3-MG / 440ESL3-4MG	220ml / 440ml	Process Magenta
220ESL3-YE / 440ESL3-4YE	220ml / 440ml	Process Yellow
220ESL3-BK / 440ESL3-4BK	220ml / 440ml	Process Black
220ESL3-LC / 440ESL3-4LC	220ml / 440ml	Light Cyan
220ESL3-LM / 440ESL3-4LM	220ml / 440ml	Light Magenta
220ESL3-MT / 440ESL3-MT	220ml / 440ml	Metallic

Roland Cleaning Solution
500ml Bottle for Eco-Sol Max
SKU: ROL-21755107

Roland Eco-Sol Max2 Ink

Designed especially for the New SOLJET Pro 4 XR-640 printer/cutter, Eco-Sol MAX 2 produces even richer, more consistent colors and ensures both the smoothest gradations and sharpest photographic details. SOLJET Pro XR-640 only. Nine colors formulated for even greater density (CMYK+ Lc+Lm, Light Black, White and Metallic Silver) Brighter, more opaque white for bolder results. Denser, more reflective metallic silver for added impact. Light black for even smoother gray scale gradations, more natural skin tones and the sharpest photographic images.



SKU	SIZE	COLOR
ESL4-4CYMAX2	440ml	Process Cyan (CY)
ESL4-4MGMAX2	440ml	Process Magenta (MG)
ESL4-4YEMAX2	440ml	Process Yellow (YE)
ESL4-4BKMAX2	440ml	Process Black (BK)
ESL4-4LCMAX2	440ml	Light Cyan (LC)
ESL4-4LMMAX2	440ml	Light Magenta (LM)
ESL4-4LKMAX2	440ml	Light Black (LK)
ESL4-WHMAX2	220ml	White (WH)
ESL4-MTMAX2	220ml	Silver (MT)
ESL4-CLMAX2	220ml	Clean (CL)

Roland Eco-UV Ink

Specifically formulated for the VersaUV's curing system, ECO-UV Ink is perfect for curing at all available print speeds, delivering high color density and wide gamut for exceptional images print after print. ECO-UV adheres to a wide range of coated and uncoated media, including foils, paper, clear films and vinyl for increased versatility. Instantly-drying and extremely flexible, ECO-UV ink produces graphics that can be stretched and applied around curved surfaces and edges without cracking. With ECO-UV, users can choose from two different formulations. ECO-UV stretches up to 220 percent with no signs of peeling and cracking, making it ideal for printing on shrink sleeves and shrink wraps, wrapping PET bottles, and for vacuum forming applications.



SKU	SIZE	COLOR
EUV-CY	220ml	Process Cyan
EUV-MG	220ml	Process Magenta
EUV-YE	220ml	Process Yellow
EUV-BK	220ml	Process Black

Solaris Eco-Solvent Inks & Flushing Fluid Cartridges

Solvent inks for Roland VersaCAMM VS, VersaStudio, VersaArt and SOLJET SJ-1045EX printers.

Maximum outdoor life for prints due to the use of automotive grade pigments. Maximum print head and damper life due to the purity of the ink. Delivers excellent adhesion, superior scratch resistance and quick drying times. Chipped 220ml and 440ml cartridges work with all firmware versions. Mix & match with OEM inks without flushing or re-profiling.

SKU	SIZE	COLOR
RMLES4-CN	440ml	Process Cyan
RMLES4-MG	440ml	Process Magenta
RMLES4-YW	440ml	Process Yellow
RMLES4-BK	440ml	Process Black
RMLES4-LCN	440ml	Light Cyan
RMLES4-LMG	440ml	Light Magenta
RMLES2-CLR	220ml	Flushing Fluid

Roland True-VIS Ink

TrueVIS INK combines with the latest Roland inkjet devices that boast four FlexFire™ print heads. Every drop of ink falls exactly where it is intended, delivering beautiful images and uniform colors at production speeds. Wide color gamut printing at a lower cost. No sacrificing color or image quality at production speeds. Pouches slide into hidden ink bay for clean use and less waste.

Lasts up to 3 years outdoors with no-lamination. Super fast dry times. GREENGUARD Gold Certified Ink UL 2818



SKU	SIZE	COLOR
TR-CY-500ML	500ml	Cyan
TR-MG-500ML	500ml	Magenta
TR-YEL-500ML	500ml	Yellow
TR-BK-500-ML	500ml	Black
TR-LT-CY-500ML	500ml	Light Cyan
TR-LT-MG-500ML	500ml	Light Magenta
TR-LT-BK-500ML	500ml	Light Black
TR-CLEAN-500ML	500ml	Cleaning Solution

Roland True-VIS2 Ink



Convenient 500ml pouches with super fast dry times. Reproduce specific colors for logos and branding with Orange ink printing. Lasts up to 3-years outdoors with no-lamination. Low-running cost ink production without sacrificing color or image quality at production speeds. True Rich Color for incomparable realism and complexity. GREENGUARD Gold Certified Ink UL 2818.



SKU	SIZE	COLOR
TR2-CY-500ML	500ml	Cyan
TR2-MG-500ML	500ml	Magenta
TR2-YEL-500ML	500ml	Yellow
TR2-BK-500-ML	500ml	Black
TR2-LT-CY-500ML	500ml	Light Cyan
TR2-LT-MG-500ML	500ml	Light Magenta
TR2-LT-BK-500ML	500ml	Light Black
TR2-OR-500ML	500ml	Orange
TR2-WH-250ML	250ml	White
TR2-CLEAN-500ML	500ml	Cleaning Solution

DuraCoat® For Gerber Edge

Sign shops and printers can create high quality, durable signs and graphics with DuraCoat® foils for Gerber Edge, Edge 2 and Edge FX printers. Available in over 30 process and spot colors, products include 55 yard cartridges and refills in 55 and 100 yard lengths. DuraCoat is designed with resins and automotive grade pigments delivering superior vibrancy and excellent UV resistance for both indoor and outdoor applications. DuraCoat saves more per square foot, when compared to OEM prices, without sacrificing print quality.

Process Colors

	Cyan	Magenta	Yellow	Black
55 Yards	C R	C R	C R	C R
100 Yards	R	R	R	R

C = CASSETTE
R = REFILL

Spot Colors

	Black	Super Opaque Black	Super Opaque White	Burgundy	Intense Red	Ruby Red	Tomato Red	Orange	Golden Yellow	Leaf Green	Pine Green	Blue	Bright Blue	Olympic Blue	Sapphire Blue
55 Yards	C		R		C									R	
100 Yards	R	R		R	R	R	R	R	R	R	R	R			R

Replacement Blades

Roland 45 Degree Carbide Blade

This 45 degree blade is used for cutting standard thickness materials. It is excellent for general purpose cutting of 2-3 mil adhesive backed substrates. The C145 is compatible with all Roland vinyl cutters and printer/cutters.

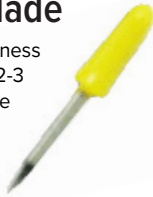

ROL-C145-SING

Roland 60 Degree Carbide Blade

This 60 degree blade is used for cutting thick materials. It is excellent for general purpose cutting of 4 mil and greater adhesive backed substrates. The C160 is compatible with all Roland vinyl cutters and printer/cutters.



ROL-C160-SING

45 Degree Carbide Plotter Blades

Our unique plotter blade design enhancement reduces blade drag and improves cutting of small characters and graphics on standard pressure-sensitive materials. Use the following recommended plotter blade angles when cutting these material thicknesses: 30 degree 2-4 mil / 45 degree 4-12 mil / 60 degree 12 mil+.

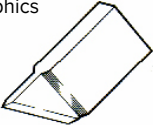

SC-1045

Target Plotters:

Anagraph Excel 1/1m
Compugraphicarty
Gerber III/IV, S/750 Sprint Series Lettersmith,GS15 Plus

45 Degree Carbide Plotter Blade

Substitutes for the Mutoh 300936 30 degree, 300937 45 degree and 300938 60 degree blades. For best results, use the following recommended blade angles when cutting these material thicknesses: 30 degree 2-4 mil / 45 degree 4-12 mil / 60 degree 12 mil+ with an offset of .021.



SC-3845

Target Plotters:

Mutoh XP-Series
Gerber Emboss Track, Odyssey
P-Cut 630 Creation

45 Degree Carbide Plotter Blades

Substitute for Ioline PN 103233. For best results, use the following recommended blade angles when cutting these material thicknesses: 30 degree 2-4 mil / 45 degree 4-12 mil / 60 degree 12 mil+ with an offset of .015.



SC-1445

Target Plotters:

Techno-Arts Switchblades
Classic
K-Cad-RBL-C
Ioline Studio 7/8 Artpro Series / Super 88 / Smartrac

45 Degree Carbide Plotter Blades

Substitute for Roland ZEC-U1001 blade. Designed for cutting very small lettering and graphics. For best results, use for cutting on 2-6 mil materials with an offset of .010.



SC-2945

Target Plotters:

All Roland
Allen Datagraph 936/800
CSR Ecom-2

45 Degree Carbide Plotter Blades

Similar to CB-09U blade. Carbide tipped blades offer much better durability and longer performance. For best results, use the following recommended blade angles when cutting these material thicknesses: 45 degree 2-6 mil / 60 degree 6 mil+. with an offset of .0175.



SC-1945

Target Plotters:

Nova Cut
American Graphtec Cutting Pro / FC-Series

60 Degree Carbide Plotter Blades

Similar to CB-09U blade offered by plotter manufacturer, except Simple Solutions' blade tips have the advantage of being constructed out of carbide, not steel! Carbide tipped blades offer much better durability and longer performance. Use the following recommended blade angles when cutting these material thicknesses: 45 degree 2-6 mil / 60 degree 6 mil+. with an offset of .0175.



SC-1960

Target Plotters:

American Graphtec Cutting Pro / FC-Series
Nova Cut

45 Degree Supersteel Blade 0.9mm (2 Pack)

These blades are genuine Graphtec 0.9mm, 45 degree Tungsten Carbide replacement blades. They fit the Graphtec CE-5000-60 and Craft ROBO Pro plotter cutters that we offer and are what comes with the original plotter cutter. Spare blades are the one item that we would have, above all else.



CB09UB-2PACK

GRAPHTEC Blue Tip Blade Holder 0.9mm

CB09 series blades for FC, FCX, CE Series



PHP33-CB09N-HS

45 Degree Supersteel Blade 1.5mm (2 Pack)

This specialty blade is useful if you are cutting a lot of rhinestone stencils or vinyl flock. It must be used only with the Red Tip blade holder (PHP32-CB15N-HS). The extra thick blade and very robust Red Tip holder provide a very long lasting cutting platform.

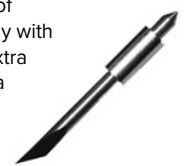

CB15UB-2PACK

GRAPHTEC Red Tip Blade Holder 1.5mm

CB15U series blades for FC, FCX, CE Series



PHP33-CB15N-HS

EQUIPMENT

FLETCHER CUTTERS



	Fletcher 2200	Fletcher 3000	Fletcher 3100	Gemini	Titan	FSC
Matboard	✓ ¹	✓	✓			
Glass up to ¼" (6mm)		✓ ²	✓ ²			
Hardboard			✓ ³			
Acrylic ¼" (6mm)		✓ ⁴	✓ ⁴			✓
Canvas				✓	✓	
Digital Prints				✓	✓	
Laminated Art/Photos (mounted on foamboard)				✓ ⁵	✓ ⁵	✓ ⁶
Foamboard ½" (13mm)	✓	✓ ⁷	✓	✓	✓	✓
Aluminum Composites (up to 4mm)						✓
Aluminum Sheets			✓ ⁸			✓ ⁹
Corrugated Plastics ½" (13mm)			✓	✓	✓	✓
PVC ½" (13mm)					✓ ¹⁰	✓ ¹⁰

- 2200 cuts up to 8-ply, cuts bevels & V-Grooves
- 3000/3100 features a built-in breakout anvil
- 3100 cuts up to 3/32" (2.4mm)
- 3000/3100 features score & break technique
- Contains a sight line strip for cutting accuracy
- FSC has a laser sight line for cutting accuracy
- 3000 cuts up to ¼"
- 3100 cuts .040
- FSC cuts .063
- Cuts up to ¼"

Fletcher 2200 Mat Cutter

Table Top Cutters

Professional level mat or mount board cutter for creating bevels and producing V-Grooves as decorative features and finishes in matboard up to 4-ply. Features a dual cutting feature for matboard specialty cutting or a 90° cutting feature for sizing matboard or cutting of foamboard up to ½" (13mm).

Available machine sizes, 48" (1.2m) or 60" (1.5m).



Titan - Trimmer | Cutter

Table Top Cutters

Designed with a dual position cutting head for cutting semi-rigid materials and a trimming feature for flexible materials such as photo paper and canvas. Engineered with a green cutting strip that gives operator a visible cut line, meaning no need for guesswork and reduces scrap from cutting mistakes.

Mounts on tabletop or stand for shop mobility. Offered in sizes from 40" (1.0m) up to 120" (3.0m).



Fletcher 3000 Multi-Material Cutter

Wall-Mounted - Free Standing Cutters

Features a 3-position cutting turret containing a glass scoring wheel, scoring tip for scoring acrylic materials and a cutting blade for picture frame matboard and foam board materials up to ¼" (6mm). A ramping feature allows the lifting of scoring wheel on top edge of glass resulting in a cleaner edge break when scoring glass. Handles material sheets up to 60" high (1.52m). Mounts on wall or freestanding installation.



Fletcher 3100 Multi-Material Cutter

Wall-Mounted - Free Standing Cutters

Versatile Wall Cutter designed with an interchangeable cutting head platform that uses multiple cutting blades, scoring tips and cutting wheel holders for cutting and scoring a large variety of materials. Handles material sheets up to 63" high (1.6m) and features an acrylic breakout function. Mounts on wall or freestanding installation.



Fletcher FSC Multi-Material Cutter

Wall-Mounted - Free Standing Cutters

Heavy-duty cutter designed with an interchangeable cutting head platform that uses multiple cutting blades, scoring tips and cutting wheel holders. Includes a V-Groove Cutting Tool used with ACM material to allow bending and fabrication techniques. Cutter handles material sheets up to 65" high (1.65m), includes a laser sight line for cutting pre-printed graphics and is equipped with a twin handle cutting head for operator control and dexterity. Mounts on wall or freestanding installation.



GeminiPro - Large Format Cutter

Table Top Cutters

Recommended for cutting large format graphics. Replaces the common method of a straight edge and knife. Offers sizes up to 120" (3.0m), eliminating the need to re-position the straight-edge. Sight line strip allows operator to line up material for entire length of cut, increasing cutting accuracy.



Premium Series Scroll Bracket

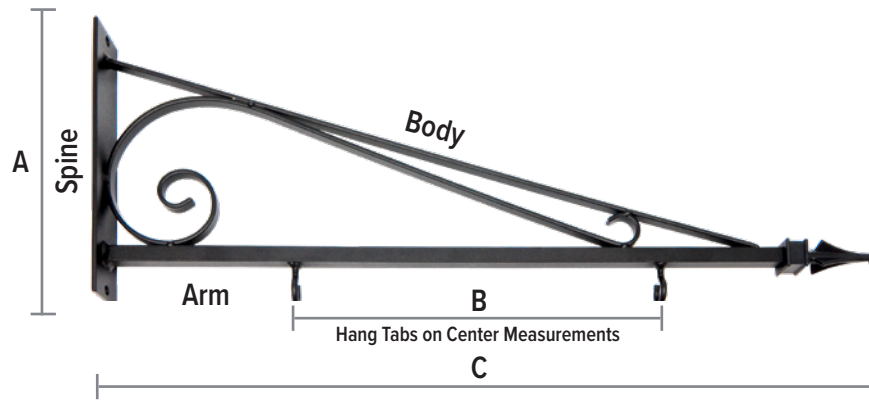

Specifications

SKU	Description	A	B	C	Spine	Body	Arm	Hang Tabs
SB20-Prem	20" Premium Scroll Bracket	8"	8"	20"	3/16" x 1 1/2" with 3/8" holes	3/16" x 1/2"	1/2" x 1/2"	3/16" wire with 1/2" hole
SB26-Prem	26" Premium Scroll Bracket	9"	12"	26"	3/16" x 2" with 3/8" holes	3/16" x 1/2"	5/8" x 5/8"	1/4" wire with 5/8" hole
SB30-Prem	30" Premium Scroll Bracket	10 1/2"	14"	30"	3/16" x 2" with 3/8" holes	3/16" x 1/2"	5/8" x 5/8"	1/4" wire with 5/8" hole
SB36-Prem	36" Premium Scroll Bracket	10 1/2"	20"	36"	3/16" x 2" with 3/8" holes	3/16" x 1/2"	5/8" x 5/8"	1/4" wire with 5/8" hole
SB42-Prem	42" Premium Scroll Bracket	11 3/4"	21 7/8"	42"	3/16" x 2" with 3/8" holes	3/16" x 1/2"	5/8" x 5/8"	1/4" wire with 5/8" hole

Standard Series Scroll Brackets

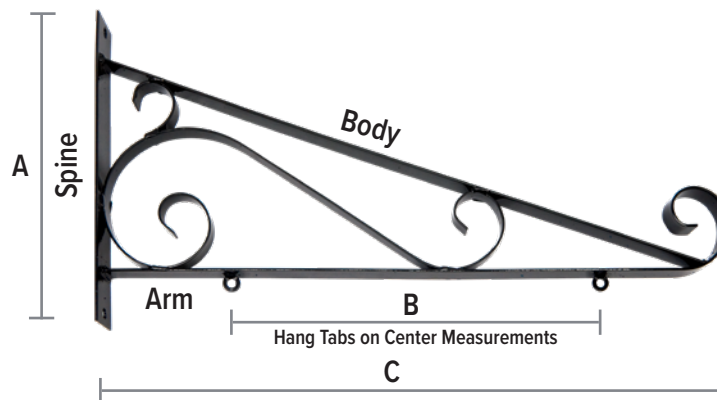

Specifications

SKU	Description	A	B	C	Spine	Body	Arm	Hang Tabs
SB18	18" Standard Scroll Bracket	11"	6 1/4"	18"	1/16" x 1 1/4" with 1/4" holes	1/16" x 3/4"	1/16" x 3/4"	3/8" washers
SB24	24" Standard Scroll Bracket	11"	10 1/4"	24"	1/8" x 1 1/4" with 1/4" holes	1/8" x 1"	1/8" x 1"	3/8" washers
SB30	30" Standard Scroll Bracket	15"	17 1/4"	30"	1/8" x 1 1/2" with 1/4" holes	1/8" x 1"	1/8" x 1"	3/8" washers
SB36	36" Standard Scroll Bracket	15"	20 7/8"	36"	1/16" x 1 1/2" with 1/4" holes	1/16" x 1"	1/16" x 1"	3/8" washers
SB42	42" Standard Scroll Bracket	16"	24"	42"	1/8" x 1 1/2" with 1/4" holes	1/8" x 1"	1/8" x 1"	3/8" washers
SB48	48" Standard Scroll Bracket	16"	23"	48"	1/8" x 1 1/2" with 1/4" holes	1/8" x 1"	1/8" x 1"	3/8" washers

*Custom made for NEPCO, therefore pricing will be higher on 30" than 48".

PREMADE PRODUCTS

BRACKETS

New England Series Scroll Bracket

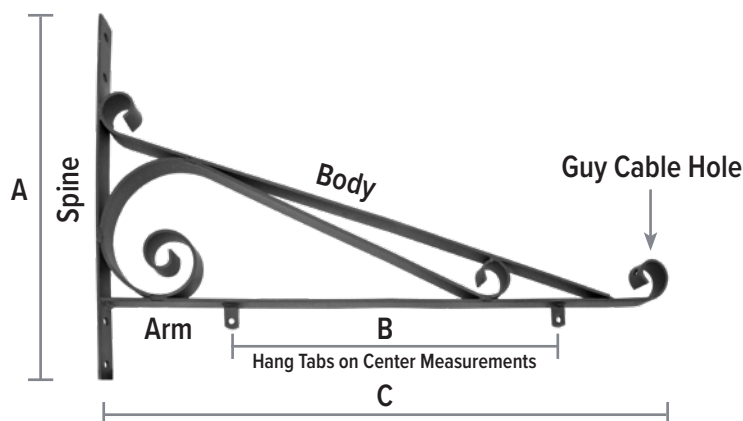
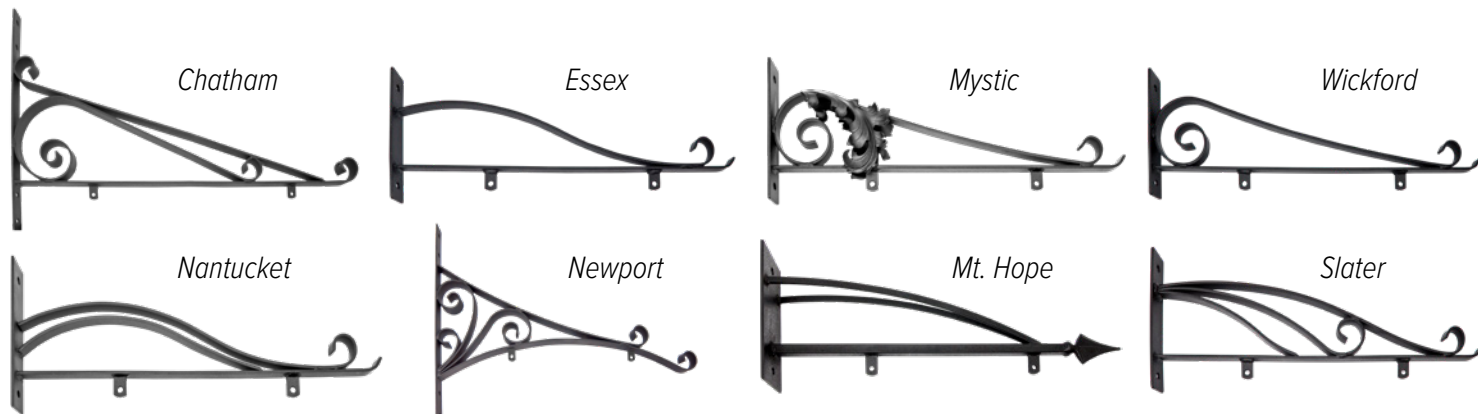

Specifications

SKU	Description	A	B	C	Spine	Body	Arm	Hang Tabs
SB30-100	30" Essex	11"	14"	30"	1/4" x 2" with 9/16" holes	1/4" x 1"	1/4" x 1"	1/4" x 1" with 7/16" holes
SB42-101	42" Essex*	13 1/2"	24"	42"	1/4" x 2" with 9/16" holes	1/4" x 1 1/2"	1/4" x 1 1/2"	1/4" x 1" with 7/16" holes
SB30-102	30" Nantucket	11 1/2"	14"	30"	1/4" x 2" with 9/16" holes	1/4" x 1"	1/4" x 1"	1/4" x 1" with 7/16" holes
SB42-103	42" Nantucket*	14 1/2"	24"	42"	1/4" x 2" with 9/16" holes	1/4" x 1 1/2"	1/4" x 1 1/2"	1/4" x 1" with 7/16" holes
SB30-104	30" Wickford	11 1/4"	14"	30"	1/4" x 2" with 9/16" holes	1/4" x 1"	1/4" x 1"	1/4" x 1" with 7/16" holes
SB42-105	42" Wickford*	13 1/2"	24"	42"	1/4" x 2" with 9/16" holes	1/4" x 1 1/2"	1/4" x 1 1/2"	1/4" x 1" with 7/16" holes
SB30-108	30" Mount Hope	10 1/2"	14"	30"	1/4" x 4" with 9/16" holes	3/4" x 3/4"	1/4" x 1/2"	1/4" x 1" with 7/16" holes
SB42-109	42" Mount Hope	11"	24"	42"	1/4" x 4" with 9/16" holes	3/4" x 3/4"	1/4" x 1/2"	1/4" x 1" with 7/16" holes
SB36-110	36" Newport*	28"	16 1/2"	36"	1/4" x 1 1/2" with 9/16" holes	1/4" x 1 1/2"	1/4" x 1 1/2"	1/4" x 1" with 7/16" holes
SB48-111	48" Newport*	32 1/2"	22 1/4"	48"	1/4" x 1 1/2" with 9/16" holes	1/4" x 1 1/2"	1/4" x 1 1/2"	1/4" x 1" with 3/8" holes
SB60-112	60" Newport*	36 3/4"	27 1/2"	60"	1/4" x 1 1/2" with 9/16" holes	1/4" x 1 1/2"	1/4" x 1 1/2"	1/4" x 1" with 3/8" holes
SB42-113	42" Chatham*	26"	24"	42"	1/4" x 1 1/2" with 9/16" holes	1/4" x 1 1/2"	1/4" x 1 1/2"	1/4" x 1" with 3/8" holes
SB54-114	54" Chatham*	25 1/2"	34"	54"	1/4" x 1 1/2" with 9/16" holes	1/4" x 1 1/2"	1/4" x 1 1/2"	1/4" x 1" with 3/8" holes
SB30-115	30" Slater	12"	14"	30"	1/4" x 2" with 9/16" holes	1/4" x 1"	1/4" x 1"	1/4" x 1" with 3/8" holes
SB42-116	42" Slater*	13 1/2"	24"	42"	1/4" x 2" with 9/16" holes	1/4" x 1 1/2"	1/4" x 1 1/2"	1/4" x 1" with 3/8" holes
SB30-117	30" Mystic	11 1/4"	14"	30"	1/4" x 2" with 9/16" holes	1/4" x 1"	1/4" x 1"	1/4" x 1" with 3/8" holes
SB42-118	42" Mystic*	13 1/2"	24"	42"	1/4" x 2" with 9/16" holes	1/4" x 1 1/2"	1/4" x 1 1/2"	1/4" x 1" with 3/8" holes

Special Notes:

- *Guy Cable Hole = 1/2"
- Chatham and Newport spine has four holes for additional support.
- All Brackets have a black textured powder coated finish.

Wall Mount - Straight Arm Brackets

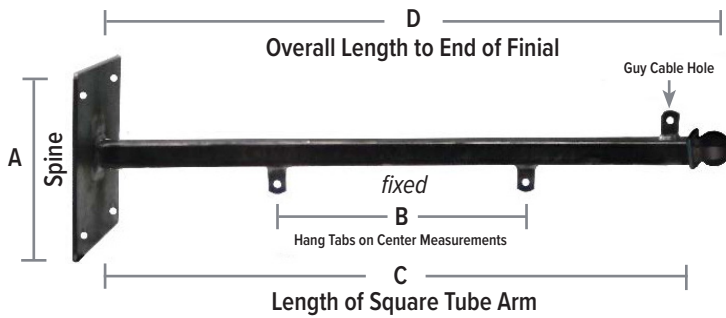

Four Unique Style Finials

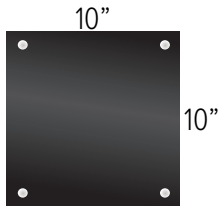

Wall Mount Baseplate Size

Special Notes:

- All steel brackets are powder coated textured black paint.
- **Guy Cable Hole = 1/4" x 1" with 7/16" Hole**
- Extra wide spine (base plate) for more surface attachment to the wall.

Specifications

SKU	A	B	C	D	Spine	Arm	Hang Tabs	End Style
SB36-119	10"	20"	36"	36 1/2"	1/4" x 10" x 10" with 9/16" holes	1 1/2" x 1 1/2" x 1/8" wall	1/4" X 1" with 7/16" holes	Flat
SB48-120	10"	28"	48"	48 1/2"	1/4" x 10" x 10" with 9/16" holes	1 1/2" x 1 1/2" x 1/8" wall	1/4" X 1" with 7/16" holes	Flat
SB60-121	10"	40"	60"	60 1/2"	1/4" x 10" x 10" with 9/16" holes	1 1/2" x 1 1/2" x 1/8" wall	1/4" X 1" with 7/16" holes	Flat
SB36-122	10"	20"	36"	38 1/2"	1/4" x 10" x 10" with 9/16" holes	1 1/2" x 1 1/2" x 1/8" wall	1/4" X 1" with 7/16" holes	Ball
SB48-123	10"	28"	48"	50 1/2"	1/4" x 10" x 10" with 9/16" holes	1 1/2" x 1 1/2" x 1/8" wall	1/4" X 1" with 7/16" holes	Ball
SB60-124	10"	40"	60"	62 1/2"	1/4" x 10" x 10" with 9/16" holes	1 1/2" x 1 1/2" x 1/8" wall	1/4" X 1" with 7/16" holes	Ball
SB36-125	10"	20"	36"	44 1/2"	1/4" x 10" x 10" with 9/16" holes	1 1/2" x 1 1/2" x 1/8" wall	1/4" X 1" with 7/16" holes	Flat Spear
SB48-126	10"	28"	48"	56 1/2"	1/4" x 10" x 10" with 9/16" holes	1 1/2" x 1 1/2" x 1/8" wall	1/4" X 1" with 7/16" holes	Flat Spear
SB60-127	10"	40"	60"	68 1/2"	1/4" x 10" x 10" with 9/16" holes	1 1/2" x 1 1/2" x 1/8" wall	1/4" X 1" w/ 7/16" holes	Flat Spear
SB36-128	10"	20"	36"	42 1/4"	1/4" x 10" x 10" with 9/16" holes	1 1/2" x 1 1/2" x 1/8" wall	1/4" X 1" with 7/16" holes	Sq. Spear
SB48-129	10"	28"	48"	54 1/4"	1/4" x 10" x 10" with 9/16" holes	1 1/2" x 1 1/2" x 1/8" wall	1/4" X 1" with 7/16" holes	Sq. Spear
SB60-130	10"	40"	60"	66 1/4"	1/4" x 10" x 10" with 9/16" holes	1 1/2" x 1 1/2" x 1/8" wall	1/4" X 1" with 7/16" holes	Sq. Spear
*SB48-131-ADJ	10"	ADJ.	48"	48 1/2"	1/4" x 10" x 10" with 9/16" holes	1 1/2" x 1 1/2" x 1/8" wall	5/16" S.S. Eyebolts w/ HDWE	Flat
*SB60-132-ADJ	10"	ADJ.	60"	60 1/2"	1/4" x 10" x 10" with 9/16" holes	1 1/2" x 1 1/2" x 1/8" wall	5/16" S.S. Eyebolts w/ HDWE	Flat
*SB48-133-ADJ	10"	ADJ.	48"	50 1/2"	1/4" x 10" x 10" with 9/16" holes	1 1/2" x 1 1/2" x 1/8" wall	5/16" S.S. Eyebolts w/ HDWE	Ball
*SB60-134-ADJ	10"	ADJ.	60"	62 1/2"	1/4" x 10" x 10" with 9/16" holes	1 1/2" x 1 1/2" x 1/8" wall	5/16" S.S. Eyebolts w/ HDWE	Ball
*SB48-135-ADJ	10"	ADJ.	48"	56 1/2"	1/4" x 10" x 10" with 9/16" holes	1 1/2" x 1 1/2" x 1/8" wall	5/16" S.S. Eyebolts w/ HDWE	Flat Spear
*SB60-136-ADJ	10"	ADJ.	60"	68 1/2"	1/4" x 10" x 10" with 9/16" holes	1 1/2" x 1 1/2" x 1/8" wall	5/16" S.S. Eyebolts w/ HDWE	Flat Spear
*SB48-137-ADJ	10"	ADJ.	48"	54 1/2"	1/4" x 10" x 10" with 9/16" holes	1 1/2" x 1 1/2" x 1/8" wall	5/16" S.S. Eyebolts w/ HDWE	Sq. Spear
*SB60-138-ADJ	10"	ADJ.	60"	66 1/4"	1/4" x 10" x 10" with 9/16" holes	1 1/2" x 1 1/2" x 1/8" wall	5/16" S.S. Eyebolts w/ HDWE	Sq. Spear

* All brackets with **adjustable hang tabs** allow the flexibility to compensate for a projecting soffit/jet work and are sold with two stainless steel eye bolts, washers, nuts and UV stabilized rubber washers to seal elements from entering the arm. Simply drill two holes at the desired eyebolt locations and the sign is ready to hang.

Pole Mount - Straight Arm Brackets

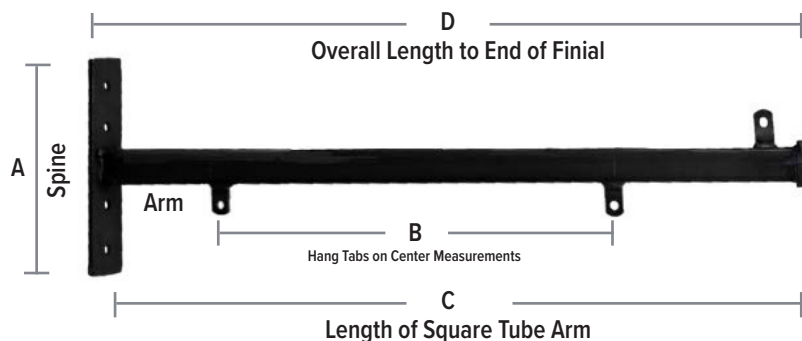

Special Notes:

- All steel brackets are powder coated textured black paint.
- Custom Steel Bracket work available - scaled drawing required for estimating.
- * Pole mount straight arm brackets can be mounted to walls.

Narrow SPINE (baseplate) specifically designed for pole mount applications.

Pole Mount Baseplate Size

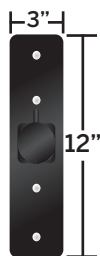

Fixed, Welded Hang Tabs Only



Two Unique Style Finials



Specifications

SKU	A	B	C	D	Spine	Arm	Hang Tabs	Guy Cable Tab	End Style
SB36-142	12"	20"	36"	38½"	¾" x 12" x 3" w/ ¼" holes	1½" x 1½" x ⅛" wall	¼" x 1" w/ ⅞" holes	¼" x 1" w/ ⅞" hole	Flat
SB48-143	12"	28"	48"	50½"	¾" x 12" x 3" w/ ¼" holes	1½" x 1½" x ⅛" wall	¼" x 1" w/ ⅞" holes	¼" x 1" w/ ⅞" hole	Flat
SB60-144	12"	40"	60"	62½"	¾" x 12" x 3" w/ ¼" holes	1½" x 1½" x ⅛" wall	¼" x 1" w/ ⅞" holes	¼" x 1" w/ ⅞" hole	Flat
SB36-145	12"	20"	36"	38½"	¾" x 12" x 3" w/ ¼" holes	1½" x 1½" x ⅛" wall	¼" x 1" w/ ⅞" holes	¼" x 1" w/ ⅞" hole	Ball
SB48-146	12"	28"	48"	50½"	¾" x 12" x 3" w/ ¼" holes	1½" x 1½" x ⅛" wall	¼" x 1" w/ ⅞" holes	¼" x 1" w/ ⅞" hole	Ball
SB60-147	12"	40"	60"	62½"	¾" x 12" x 3" w/ ¼" holes	1½" x 1½" x ⅛" wall	¼" x 1" w/ ⅞" holes	¼" x 1" w/ ⅞" hole	Ball

Projection Stationary Brackets

Projection stationary brackets are welded & pre-punched using the highest grade of 1/4" steel wall plate. Horizontal projection tubes are made of 1" x 1" x 1/8" heavy square steel with end caps for protection from moisture penetration. Each bracket is textured powder coated black for ultimate weather protection.

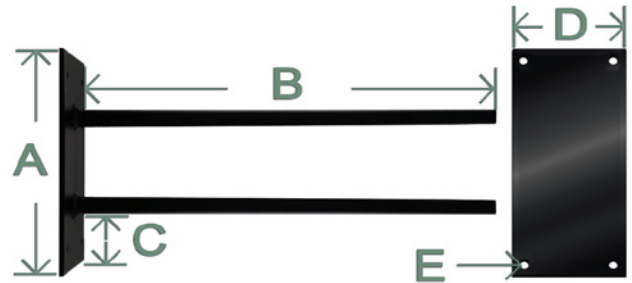

SKU	A	B	C	D	E
SB26-139	13"	26"	3"	1/4" x 8"	7/16"
SB34-140	18"	34"	4"	1/4" x 8"	7/16"
SB46-141	23"	46"	5"	1/4" x 8"	7/16"

3 Size Options!

Mounting Examples

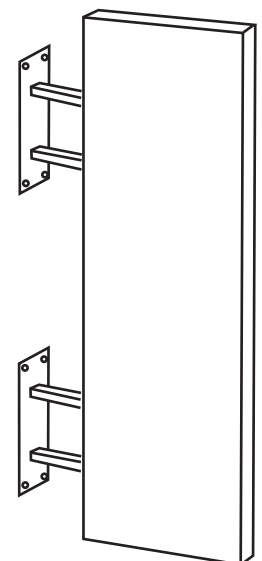
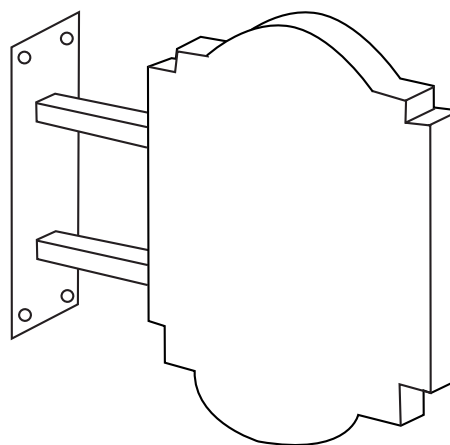
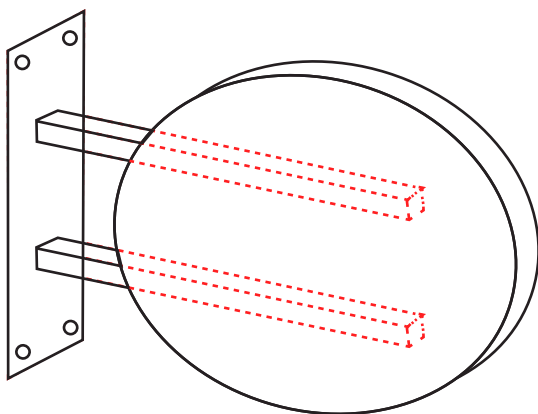

All Projection Stationary Brackets can be used with Single Face & Double Faced Applications!

PREMADE PRODUCTS BRACKETS

Universal Sign Brackets

Universal Sign Brackets are welded & pre-punched using the highest grade of $\frac{3}{16}$ " steel available. Each bracket is powder coated white for ultimate protection and has four $\frac{2}{16}$ " holes in each corner & $\frac{1}{4}$ " counter sink for multi-fastening options.

Designed to be used with a wide variety of signage types including, but not limited to, high density urethane, wood, illuminated & non-illuminated types of signage.

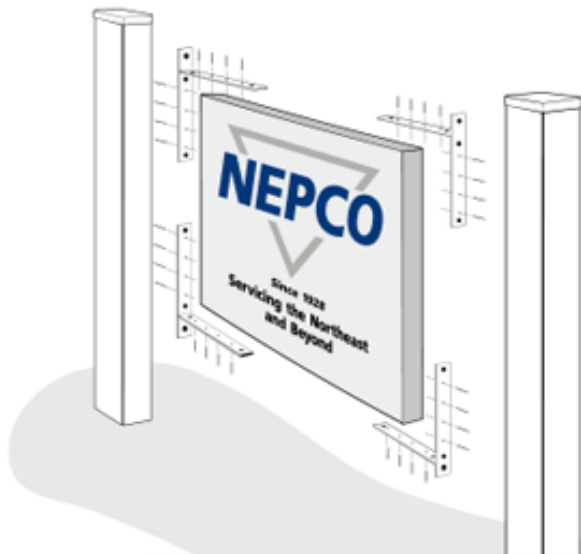

4 Bracket Size Options!

SKU	VERTICAL DIMENSION	HORIZONTAL DIMENSION
UNIV-XSM	7.5"	6 $\frac{3}{16}$ "
UNIV-SM	13.5"	11.5"
UNIV-MED	24"	22"
UNIV-LG	24"	44"

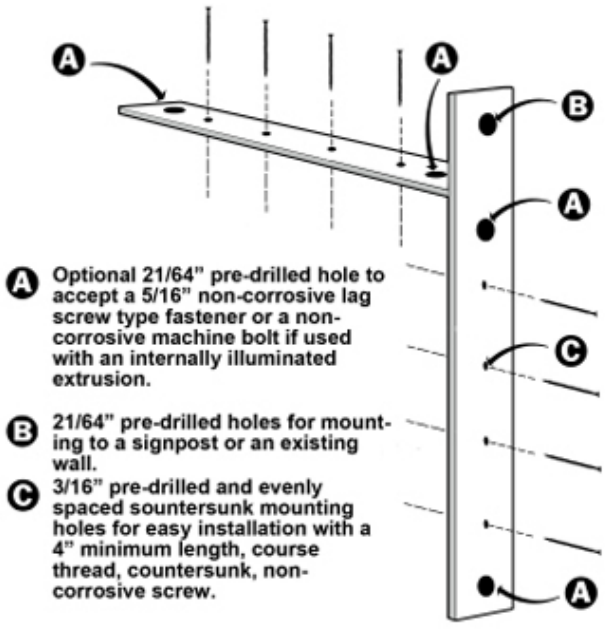

Sign Mounting Examples

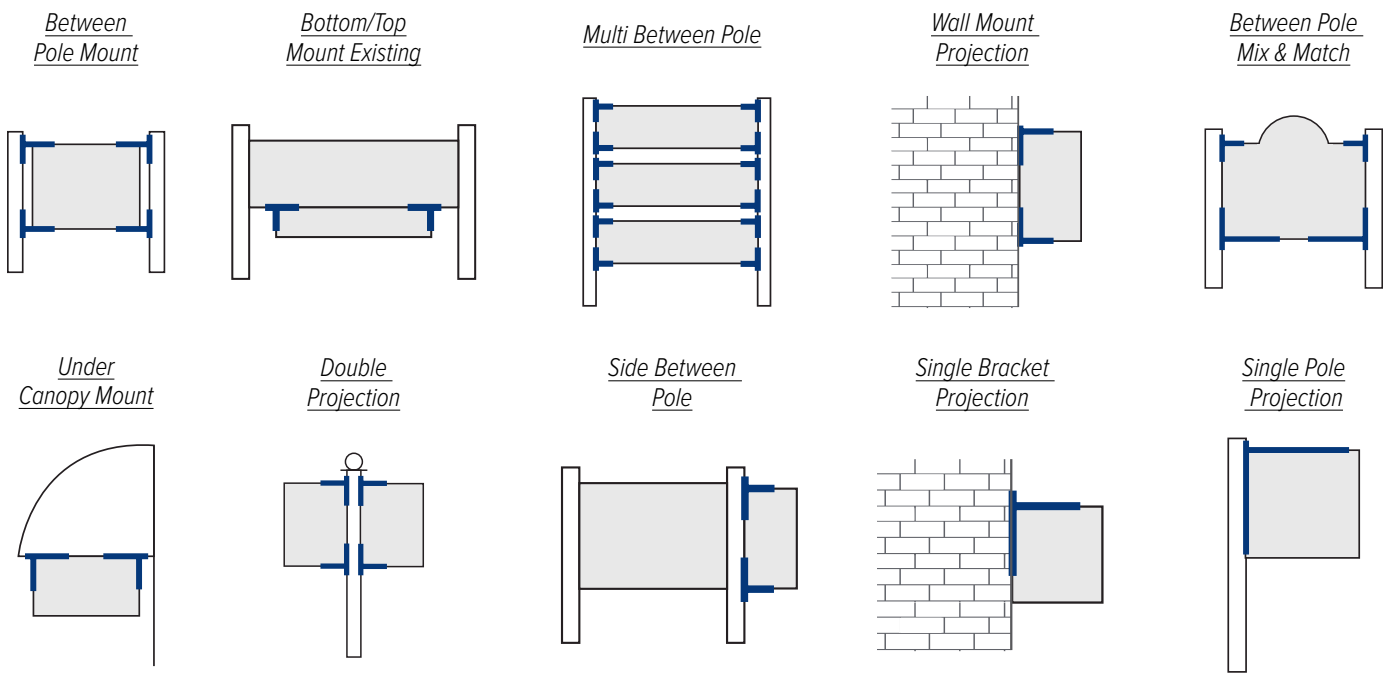

FastClip No Weld Aluminum Bracket System

The FastClip system completely eliminates the need to weld awning or sign components together. All you need is a screw gun and self-tapping Tek screws. Great to fix broken welds in the field!

FastClip #1
SKU: AWG-1CLIP

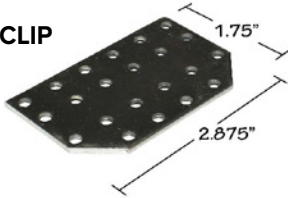

FastClip #2
SKU: AWG-2CLIP

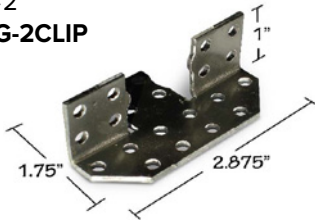

FastClip #3
SKU: AWG-3CLIP

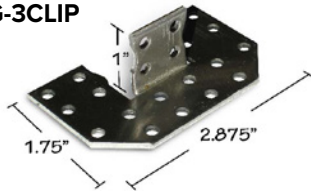

FastClip #4L
SKU: AWG-4LCLIP

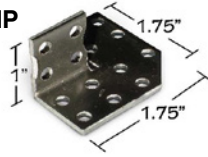

FastClip #4R
SKU: AWG-4RCLIP

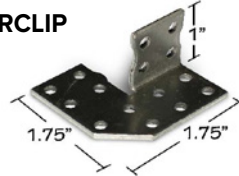

FastClip #5L
SKU: AWG-5LCLIP

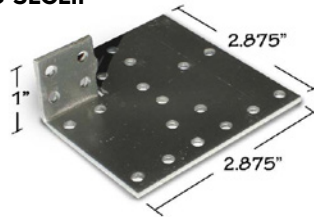

FastClip #5R
SKU: AWG-5RCLIP

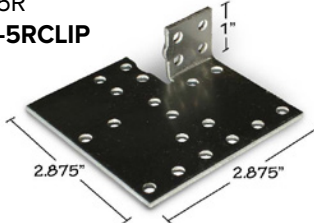

FastClip #6
SKU: AWG-6CLIP

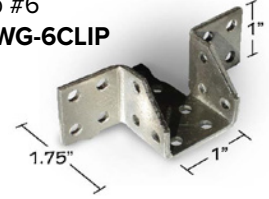

FastClip #7
SKU: AWG-7CLIP

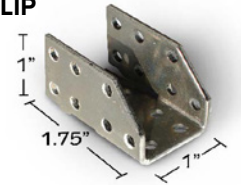

FastClip #8
SKU: AWG-8CLIP

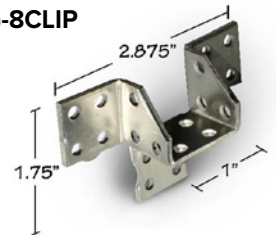

FastClip #9
SKU: AWG-9CLIP

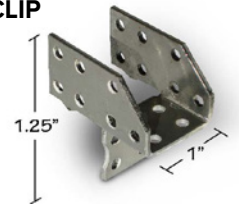

How To Use It

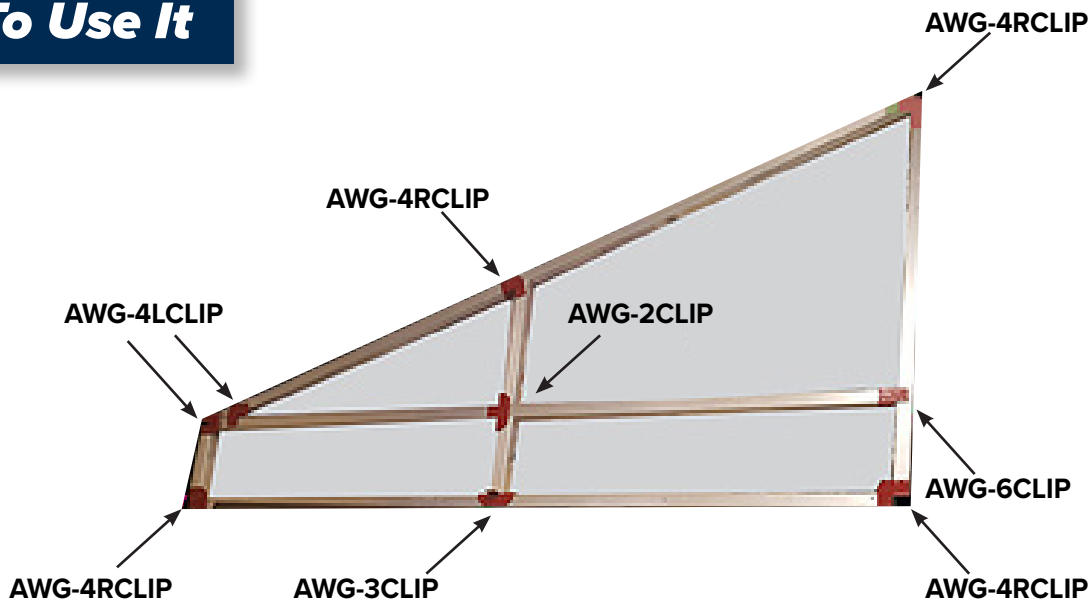

PREMADE PRODUCTS

BRACKETS

Aluminum Tube Frame Sign Brackets & Moldings

Fabricating Aluminum Commercial Signs

Assemble a 1" x 1" perimeter frame of aluminum tubing with corner brackets. For larger signs additional support can be obtained by installing tubing at intervals along the frame.

Install a pre-finished 040 aluminum face sheet in your choice of background color. You can then letter your copy or mount pressure sensitive graphics or drill the background sheet to mount plastic letters.

Install a pre-finished aluminum frame molding to complete the sign.

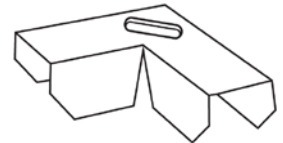
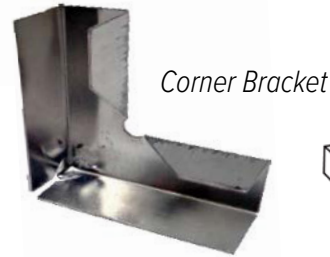
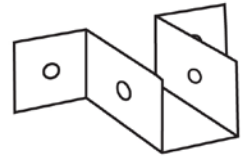
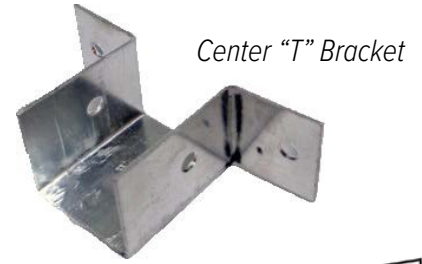
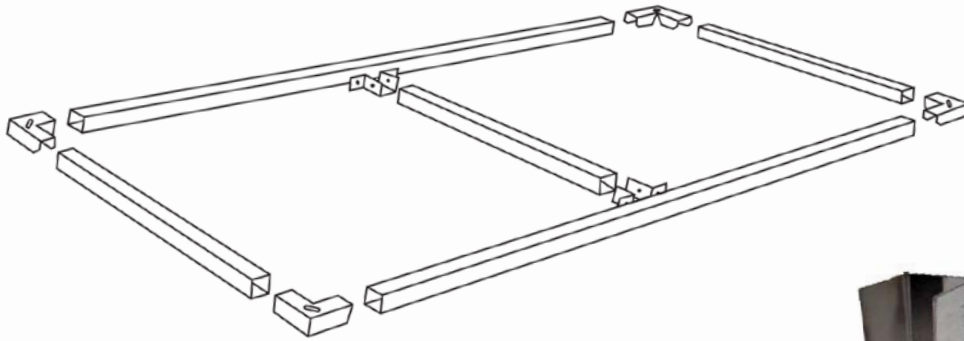

SKU	DESCRIPTION
CRN/BRK	Corner Bracket
TEE/BRK	Center "T" Bracket

Black "J" Molding 1 3/8" x 1/4" x 24'5" Lengths

Clean up any of your signs with our professional black powder coated molding! 1 3/8" x 1/4" x 24'5" Lengths .0625" - 1/16" Thickness.

SKU	COLOR
1943/BLK	Black

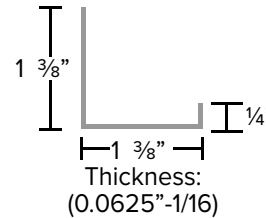

Clear "L" Molding 3/4" x 1" x 21' Lengths

Clean up any of your signs with our molding with brushed aluminum exterior! 3/4" x 1" x 21' Lengths - .0625" - 1/16" Thickness.

SKU	COLOR
994440CLR	Brushed Silver

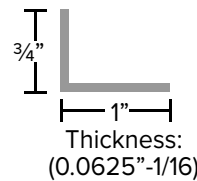

Chrome Aluminum Tubing 1" x 1" x 21' x .031

Size: 1" x 1" Thickness: .031 Length: 21 feet Finish: Chrome Mill

SKU	FINISH
21/1/TUBE	Chrome Mill



Post Clip - Multi-Use Sign Hanger



Dimensions: 3" L x 1.5" W x 1.5" H
Substrate Screw Hole: 1/4"
Post Screw Hole: 3/8"



Post Clip™ Features & Benefits

- Strong and Lightweight
- .090 Corrosion-Resistant **Stainless Steel**
- Strong, Folded, Single-Piece Construction
- Bright White, Powder-Coated Finish
- Saves time & money with easy installation
- Eliminates Sign Failure From Sagging or Twisted L-Bracket
- No Welds to Break
- **NO RUST!**

Order by Substrate Thickness (1/4", 1/2" or 3/4")

Available Individually or in Case Quantity (100 pcs/case)
 (Parts are individual plastic bagged to prevent scratching)

SKU	SIZE
1/4PSTCLP-SS	1/4"
1/2PSTCLP-SS	1/2"
3/4PSTCLP-SS	3/4"

*Fits perfectly on any post 3" x 3" or greater.
 Attaches to wood, metal, or nearly any
 substrate using stainless steel screws.*

"U" Brackets for Solid Substrate Mounting

- Mount Solid Substrate between post or off wall
- Can use Super center brackets for added strength
- Aluminum white powder coated finish and will not rust
- Available in 3 sizes 1/4" – 1/2" – 3/4"

Order by Substrate Thickness (1/4", 1/2" or 3/4")

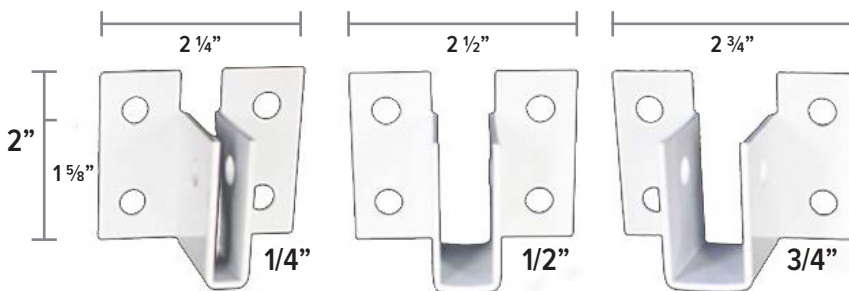

Post Bolt Fasteners SKU: PB2

Designed to be used in an application where access is restricted to one side only.

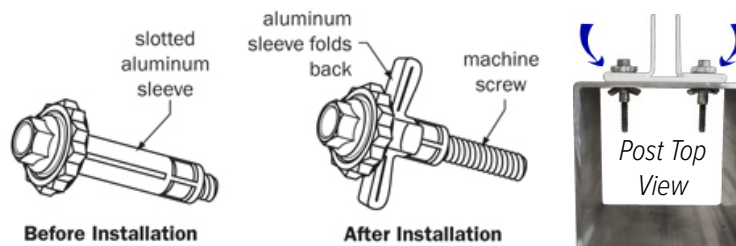

Mill Finish Aluminum Corner Angles for Sign Mounting

Part Number - #5318

Description - Medium Body Corner Angle

Size - Height 1 3/4" x Width 1 3/4" x Thickness 1/4" x Length 6 7/8"

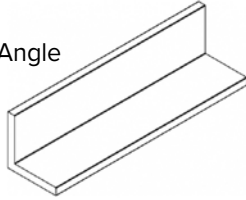

Part Number - #5978

Description - 1Part 2Part 9" D/F Body Corner Angle

Size - Height 1 3/4" x Width 1 3/4" x Thickness 1/4" Length 6 5/16"

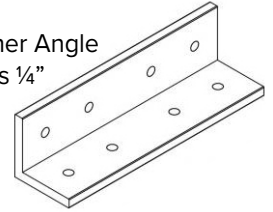

Part Number - #5304

Description - Frame Corner Angle

Size - Height 2" x Width 2" x Thickness 3/16" x Length 9/16"

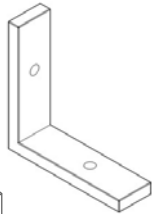

Part Number - #5981

Description - 1Part 2Part 6" S/F Body Corner Angle

Size - Height 1 3/4" x Width 1 3/4" x Thickness 1/4" x Length 4 3/16"

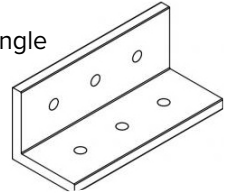

Part Number - #5305

Description - Frame Corner Angle

Size - Height 1 3/4" x Width 1 3/4" x Thickness 1/4" x Length 1 1/16"

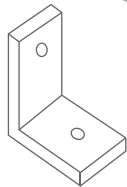

Part Number - #5985

Description - 1Part 2Part 6" D/F Body Corner Angle

Size - Height 1 3/4" x Width 1 3/4" x Thickness 1/4" x Length 3 3/4"

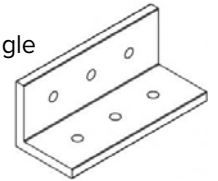

Part Number - #5325

Description - Corner Angle, Extended 1/4 Round Retainer/ with Reveal

Size - Height 1" x Width 1" x Thickness 1/8" x Length 1/2"

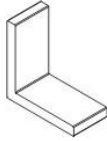

Part Number - #5312

Description - Wide Body Corner Angle

Size - Height 1 3/4" x Width 1 3/4" x Thickness 1/4" x Length 10 1/16"

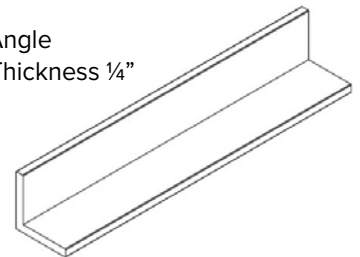

Part Number - #5335

Description -Series 3 Slide Body Corner Angle

Size - Height 1" x Width 1" x Thickness 1/8" x Length 2 1/4"

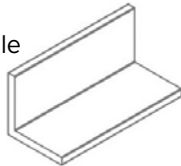

Part Number - #5977

Description - 1Part 2Part 12" D/F Body Corner Angle

Size - Height 1 3/4" x Width 1 3/4" x Thickness 1/4" x Length 9 5/16"

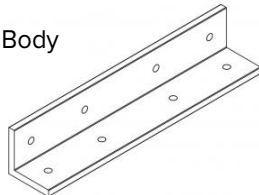

Part Number - #5979

Description - 1Part 2Part 8" S/F Body Corner Angle

Size - Height 1 3/4" x Width 1 3/4" x Thickness 1/4" x Length 6 3/16"

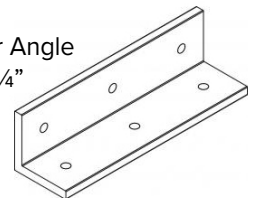

Sign Mounting Examples

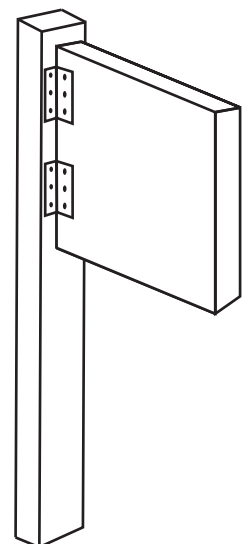
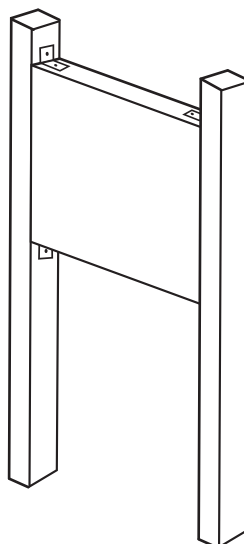
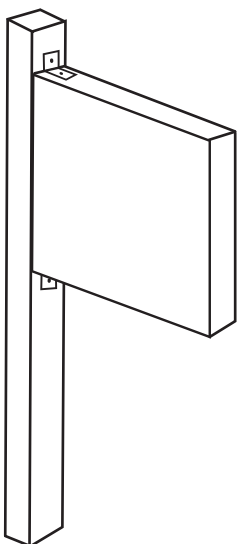

Galvanized Steel Wall Brackets



301



304



306



307

SKU	SIZE	ANGLE	HOLE	SLOT
301	3/16" x 2" x 2 1/2" x 2 1/2"	90°	5/8"	9/16" x 1"
304	3/16" x 1 1/2" x 2" x 2"	45°	5/8"	9/16" x 1"
306	3/16" x 2" x 2 1/2" x 5"	90°	5/8"	9/16" x 1"
307	3/16" x 1 1/2" x 2" x 2"	90°	5/8"	9/16" x 1"

Sign Hangers



Stainless Steel



Stainless Steel
with white powder coating



6209
Galvanized Steel

SKU	DESCRIPTION	SIZE	HOLES
LG-HANG	Stainless Steel	3/4" x 3" long x 1" wide	3/4"
LG-HANG-WHT	Stainless Steel w/ white powder coating	3/4" x 3" long x 1" wide	3/4"
SM-HANG	Stainless Steel	1/2" x 3" long x 1" wide	1/2"
SM-HANG-WHT	Stainless Steel w/ white powder coating	1/2" x 3" long x 1" wide	1/2"
6209	Galvanized Steel pole mounting bracket	3/16" x 1/2" x 7 1/4" x 7 1/4"	3/8"

Chain Link Linklip Bracket Mounting System

Linklip is a link clip bracket mounting system for attaching signs to chain link fence. One size Linklip fits all four chain link fence sizes. Each Linklip includes one bolt for fastening sign to fence. Linklip is ideal for hanging corrugated plastic, metal signs, banners and substrates. Linklips take the hassle out of hanging signs on chain link.

Clip Size - 7/8" W x 2 5/8" L x 1/4" H

Bolt Thread - 5/16-18"



SKU	QTY
SLK300B	100 pack'



Can be used with new or old sign construction!

Dividers

Part Number - #1946
Description - 1" Z-Molding

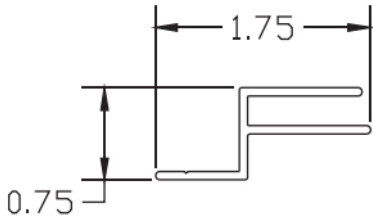

Part Number - #2140
Description - 1 5/16" Econo Divider

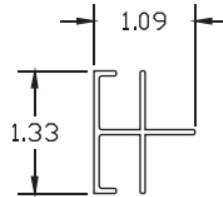

Part Number - #2133
Description - 1 1/2" Divider

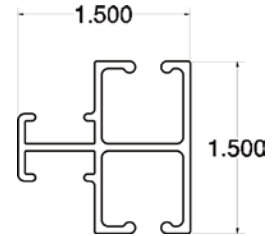

Part Number - #1910
Description - 1 1/2" Divider

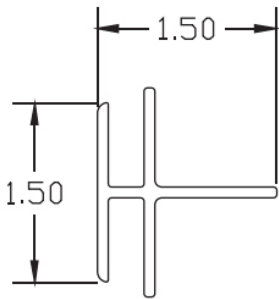

Part Number - #1905
Description - 1.625" Divider

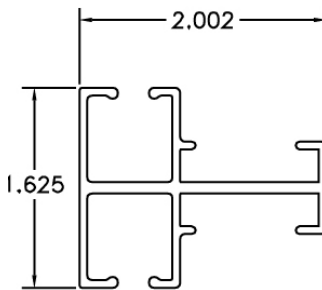

Part Number - #2138
Description - 2" Divider

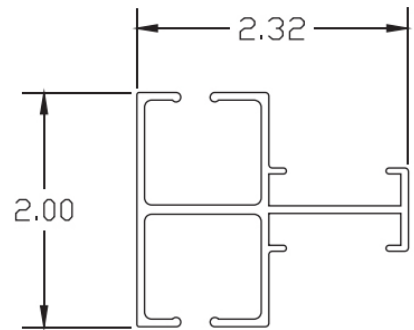

Divider Angles

Part Number - #5300
Description - Frame Corner Angle
 1 3/4" x 1 3/4" x 1/4" (1 1/16") w/ Notches

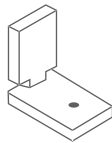

Designed to be used with

Part Number - #2138
Description - 2" Divider

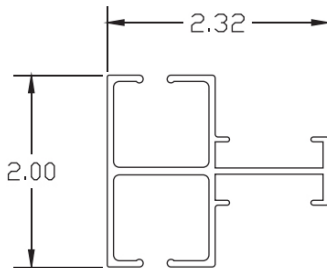

Part Number - #5301
Description - Divider Corner Angle With
 Notches 2" x 2" x 3/16" (9/16") For part #2053

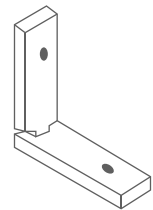

Designed to be used with

Part Number - #2133
Description - 1 1/2" Divider

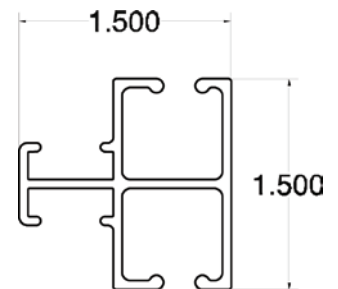

The Billboard™

- **Twice as big as a Signicade**
- Perfect for eye-catching outdoor advertising
- **Six Signs per Frame**
- Two 36" x 48" signs
- Two side signs
- Two sided top rider
- **Wheels for easy movement**
- No installation needed
- **Quick-Change™ Feature**
- Change signs in seconds, slide in a sign
- **"Stay Tabs" hold main signs securely in place**
- **Internally weight with dry sand**



SKU	OUTSIDE DIMENSION
A-FRAME-198W	58"H x 39"W x 3.125"D



Signicade® Deluxe

- **Change signs in seconds**
- With patented Quick-Change™ feature, signs easily slide in and out
- Use Coroplast™ signs or other rigid sign material 3/16" thick or less
- Holds two signs, 24"W x 36"H
- **Stay Tabs™ ensure signs stay securely in place**
- **No Maintenance**
- All plastic, use indoors and outdoors
- **No tape, Velcro®, or screws needed**
- Eliminates fastener damage to signs
- **Can internally weight with sand**
- **Hinges lock in open position**
- **Weight:**
20 lbs
- **Available Colors:**
Black or White



SKU	OUTSIDE DIMENSIONS
A-FRAME-DLX-BLK	46.375"H x 27.125"W x 3.125"D
A-FRAME-DLX-WHT	46.375"H x 27.125"W x 3.125"D

White 24 Gauge Steel A-Frame

This frame is a sturdy magnetic receptive steel white powder coated frame that is ready to apply vinyl graphics.

SKU	SIZE
MCA 24x34	34 3/4"H x 24"W

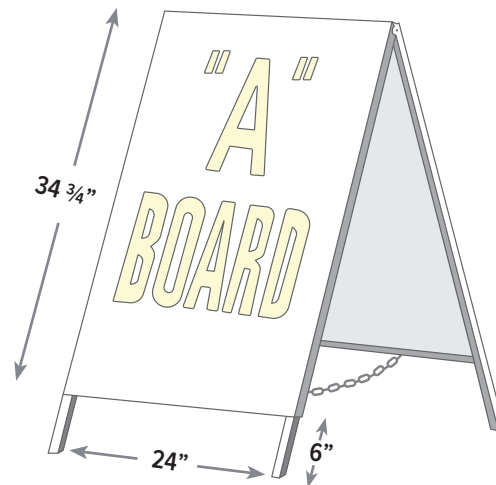

PREMADE PRODUCTS

A-FRAMES

Signicade®

- All Plastic Sign Frame
- Recessed sign area helps to protect sign faces
- Holds two signs, 24"W x 36"H
- Sign face can receive vinyl sheeting (with surface preparation), metal, Coroplast™, or acrylic sign blanks
- Can be internally ballasted with sand
- Molded-in handle for easy portability
- Stacking lugs facilitate handling by keeping stacked units from sliding and damaging sign faces
- **Weight:** 18 lbs



PLASTICADE®

Need an Inexpensive Blank for your Signicade?

NEPCO offers pre-cut
23 3/4" x 35 3/4" x .040
white styrene blanks.
*see page 86

SKU	OUTSIDE DIMENSIONS
A-FRAME-PLAS	45"H x 25"W x 3"D

Quik Sign®

- Change signs in seconds
- With patented Quick-Change™ feature, signs easily slide in and out
- Use Coroplast signs or other rigid material
- 3/16" thick or less
- Holds two signs, 24"W x 18"H
- "Grabber Hinges" hold a sign rider
- All plastic sign frame - no rust, splinters, discoloration, or maintenance
- Won't tear or scratch car seat upholstery
- Molded-in handle assures easy portability
- Stacking lugs nest into each other when units are stacked which prevents sliding
- **Weight:** 7.5 lbs



SKU	OUTSIDE DIMENSIONS
QUIK	31.5"H x 26"W x 2"D

Windsigns Frame

Bundle Pack



Specifications:

Dimensions (Frame Only): 42.9"H x 26"W x 2.5"D

Dimensions (Base Only): 7.1"H x 28.7"W x 18.1" D

Dimensions Assembled: 53"H x 28.7"W

Total Weight Assembled: 25 lbs.

Weight (Base Only): 9 lbs.

Sign Insert Size: 24" x 36" (3/16" thick)

Sign Insert Weight Limit: Max. of 5 lbs. per side

- Resists head-on winds up to 60 mph *wind resistance varies for each size frame*
- Change signs in seconds
- "Quick-Change"™ feature, signs easily slide in and out
- Use Coroplast™ signs or other material 3/16" thick or less
- All plastic frame (Eliminates torn, bent, or rusted frames) - powder coat finish!
- Plastic base has two built-in wheels (Can be filled with dry sand)
- Tool free assembly

SKU	SIZE
1822-SIGN-KIT	2' x 3' Sign-Kit
1822-BASE-KIT	2' x 3' Base-Kit

Bundle Pack Includes:
1822-SIGN-KIT - 1822 Windsign II 2' x 3' Sign-Kit
1822-BASE-KIT - 1822 Windsign II 2' x 3' Base-Kit

Real Estate Frames

All Real Estate Frames are either bolt in, slide in or clip in - except the Swing/Folding Frame.

SKU	TYPE OF FRAME	SIZE	CLIPS (OPTIONAL)
A-B24	Top & Bottom Ryder Frame	18" H x 24" W	8 Clips
B-F24	No Ryder Frame	18" H x 24" W	4 Clips
C-FF24	Folding A-Frame	18" H x 24" W	2 Sides - 8 Clips
D-FF36	Folding A-Frame	36" H x 24" W	2 Sides - 8 Clips
F-HR24	Bottom Ryder Frame	18" H x 24" W	6 Clips
G-HR2436	Bottom Ryder Frame	24" H x 36" W	8 Clips
K-HR28	Bottom Ryder Frame	20" H x 28" W	6 Clips
S904SWING	Swing/Folding Frame	18" H x 24" W	N/A*

*Item is 2 sided with 3/8" round rod with 2 rings attached

Don't Forget Clips!

3/4" clips snap onto 3/4" angle iron securing panels to frame.
Available in Black SKU: CLIP1

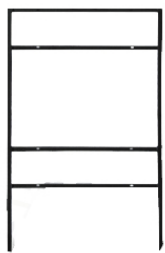

A-B24

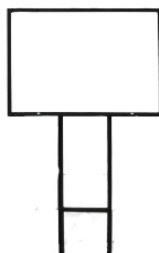

B-F24



C-FF24



D-FF36

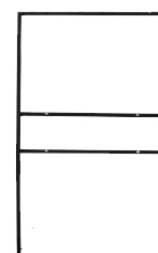

F-HR24

G-HR2436

K-HR28



S904SWING

Step Stakes



Standard Stake



Sturdy Stake

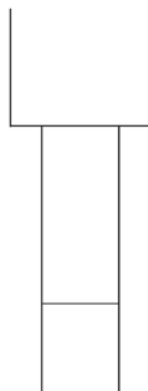

Medium Stake

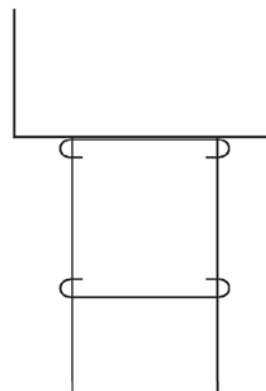

Heavy-Duty Stake

SKU	DESCRIPTION	SIZE
CORO1I-RR	Standard Stake	10" W x 30" H with 7 1/2" tall prongs
CORO1SS	Sturdy Stake	10" W x 30" H with 7 1/2" tall prongs
CORO12I	Medium Stake	12" W x 33" H with 9" tall Prongs
CORO18I	Heavy-Duty Stake	18" W x 27" H with 9" tall Prongs

Quantity pricing available - Call for more information

Buy any combination of 100 or more Step Stakes / Coroplast Blanks & receive additional discounts!

*Coroplast Blanks on page 86

PREMADE PRODUCTS

LETTERS & TRACK

Pronto Rigid Letter Set .080" Thickness



Pronto Changeable Copy Letters and Numbers Set is a cut above the traditional saw-cut changeable copy. Its patented acrylic panel design prevents scratches and its UV Inks have no harmful VOCs. It also has molded feet to keep panels from sticking within the track.

****Designed to be used with Pronto Track only!**

ADM Style **ABCDEFGHIJKLMN
OPQRSTUVWXYZ
1234567890.,:;-
&¢\$?!'"" % /**

CHARACTER	QUANTITY	COLOR
E	7	Black
A I	6	Black
O U	5	Black
L N R S T P	4	Black
F G H M	3	Black
B C D	3	Black
J K V W Y Z	2	Black
Q X \$ ¢	1	Black
0 1 2 3 4 5 6 7 8 9	1	Red
Total	100	

SKU	SIZE
4-PRONTO	4"
6-PRONTO	6"
8-PRONTO	8"

Check Out These Additional Accessories

Acrylic Pronto Letter Tracks (.250 Thickness)

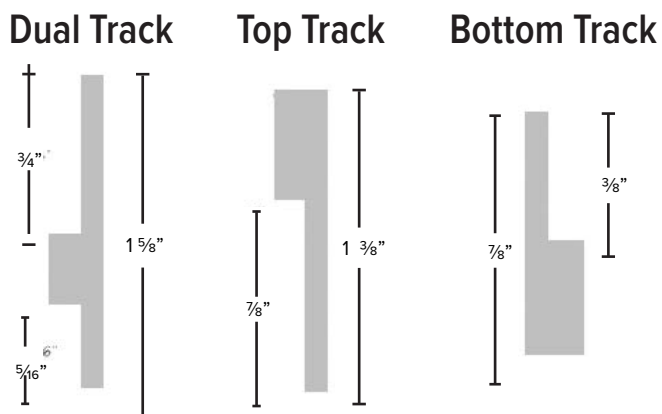

SKU	TRACK TYPE	SIZE
D-PRONTO	Dual Track	8'
D-PRONTO-12	Dual Track	12'
T-PRONTO	Top Track	8'
T-PRONTO-12	Top Track	12'
B-PRONTO	Bottom Track	8'
B-PRONTO-12	Bottom Track	12'

Pronto Change Arms

SKU	SIZE
3318	6'-18' with 3 3/4" Standard Cup



Flex Changeable Letter Sets - .030 Thickness

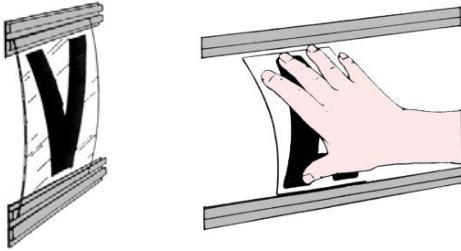

Flex Changeable Copy Letters and Numbers Set is a low-cost economical letter set. With its clear PVC backing, these letters are **not designed to be laid flat against surfaces. They must be bowed to allow wind to pass for expansion and contraction.** Flex Changeable Copy Letters and Numbers must be used in a well vented application. They cannot be used in a non-vented vandal-proof application due to the fact that they heat & warp.

****Designed to be used with Texas Track only!**

4" Height - .030" Thickness (Bold)

CHARACTER	QUANTITY	COLOR
A E I N O R S T	12	Black
L	8	Black
B C D F G H J K M P U Y	6	Black
Q V W X Z , & * !	4	Black
! % / . -	2	Black
6	8	Red
5	5	Red
0 1 2 3 4 7 8	4	Red
. ¢ \$ - →	2	Black
Total	273	

**ABCDEFGHIJKLMNPO
QRSTUVWXYZ
! % , / & . - \$ * ¢ →
012345678**

SKU	SIZE
4-FLEX-BOLD(48)	4"

6" Height - .030" Thickness (Bold)

CHARACTER	QUANTITY	COLOR
A E N O R S T	12	Black
B C D F G H I J K L M P Q U V X Y Z	6	Black
0 1 2 3 4 5 6 7 8 9	6	Red
% ¢ - . \$	6	Black
Total	288	

**ABCDEFGHIJKLMNPO
QRSTUVWXYZ
! % , / & . - \$ * ¢ →
012345678**

SKU	SIZE
6-FLEX-BOLD(46)	6"

6" Height - .030" Thickness (Condensed)

CHARACTER	QUANTITY	COLOR
A E I N R S	12	Black
O T	8	Black
B C D F G H J K L M P U	6	Black
Q V W X Y Z . - * !	4	Black
% /	2	Black
0 6	12	Red
5	9	Red
1 2 3 4 7 8 \$	6	Red
Total	279	

**ABCDEFGHIJKLMNPO
QRSTUVWXYZ
& % / . - * !
123456780**

SKU	SIZE
6-FLEX-COND(44)	6"

PREMADE PRODUCTS

LETTERS & TRACK

8" Height - .030" Thickness (Condensed)

CHARACTER	QUANTITY	COLOR
A E I N O R S T	14	Black
B C D F G H J K L M P Q U W . ! :	6	Black
V X Y Z	4	Black
1 2 3 4 7 8 \$ -	4	Red
0 5	7	Red
6	14	Red
% ¢ * . /	6	Red
Total	300	

ABCDEFGHIJKLMN
OP
QRSTUVWXYZ
& % / . - * !
123456780

SKU	SIZE
8-FLEX-COND(28)	8"

8" Height - .030" Thickness (Bold)

CHARACTER	QUANTITY	COLOR
A E N O R S T	10	Black
B C D G H J L Q U W	6	Black
F K M P V X Y Z % - ? "	5	Black
:, ! .	6	Black
" #	2	Black
6	12	Red
0 1 2 3 4 5 7 8 \$ ¢ -	6	Red
& * /	2	Black
Total	312	

ABCDEFGHIJKLMN
OP
QRSTUVWXYZ
! % , / & . - \$ * ¢ →
012345678

SKU	SIZE
8-FLEX-BOLD(36)	8"

Don't Forget!

Texas Track (For Flex Letters - 7'6" - .040" Thickness)



This Letter Track holds Flex Changeable Copy Letters and Numbers Set onto any Sign. The Texas Track is made of Polycarbonate plastic with a length of 7'6" long (or 90 inches) and can be cut to the sign size you need. To attach you can drill a hole at the center of the track and use screws or rivets into your letter board. You can also use double-sided VHB tape to secure it as well as glue.

SKU	SIZE
7-6-TT (94)	7' 6"

Sign Bases

Stable for high-winds, heavy traffic areas, schools, economical and pedestrian Friendly!

The rubber and steel sign bases are ideal for parking lots, crosswalks, guard booths, schools, malls, industrial and construction sites, or anywhere portable or where temporary signs are needed.

The 60lb. rubber base unit is stable enough to withstand high winds and bad weather, as well as heavy traffic areas. For excessive high wind areas there is also an optional 30 pound extender to add to our octagon bases creating additional stability. (Special Order Only.) The 30lb. rubber base & our 22lb. steel bases are ideal for indoor or light temporary use.

SKU	SIZE
GP4-BASE	22 LB.
TSB-30-BASE	30 LB.
TSB-60-BASE	60 LB.



22lb. Steel Base
with Set Screw Bolt

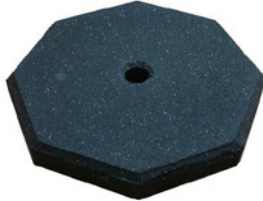

30lb. Rubber Base

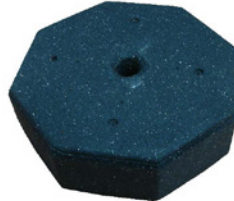

60lb. Rubber Base



Stop Signs

Available in 2 sizes

24" x 24" x .080
SKU: R-1-24

30" x 30" x .080
SKU: R1-1

Don't forget about additional accessories!

The 30lb & 60lb base are compatible with ALL accessories.
The 22lb base is only compatible with the GP-POST & TSB-POST-5.

Base Wheels

SKU: TSB-WHEELS



12" Adapter - with 2 Bolts

SKU: TSB-ADP



6' 1.12lb U-Channel Post

SKU: U-6-1LB



9lb. Steel Post

SKU: GP-POST



60" PVC Post - with 2 Brackets

SKU: TSB-POST-5



Galvanized Steel Round Sign Post

Providing an aesthetic appearance and durable exterior life, cities, counties and state departments use round posts as their choice of sign post.

SKU	SIZE
SPR10	2 3/8" x 10'
SPR12	2 3/8" x 12'



SKU: PPB-12



You may also need... Steel Post Brackets

Two-piece cast aluminum clip for attaching signs to 2 3/8" round pipe posts. Single-face only. Sold in pairs.

PREMADE PRODUCTS

TRAFFIC SIGNS & POST

Reflective Premade Traffic Signs

- Holes: Two 3/8 inch mounting holes top and bottom centered.
- Can be installed on to a post, wall, or a fence.
- Meets MUTCD sign regulations for parking lots.

SKU	SIZE
HANDICAPPED-REF	12" x 18"
NO-PARKING	12" x 18"
R-1-24	24" x 24"
R1-1	30" x 30"



R-1-24 & R1-1



NO-PARKING



HANDICAPPED-REF

Aluminum Sign Post

- Bright white, powder-coated finish
- Will not crack, rot, twist or warp!
- No painting required!
- No trips to the lumber yard needed!
- Comes with a plastic protective sleeve

SKU	SIZE
A-1480-123	2" x 2" x 8' x .093"
A-1480-124	2" x 2" x 12' x .093"
WLB-582-10	4" x 4" x 10' x .125"
WLB-605-16	6" x 6" x 16' x .150"
WLB-605-8	6" x 6" x 8' x .150"



Post Bolt Fasteners
SKU: PB2
Designed to be used in an application where access is restricted to one side only.

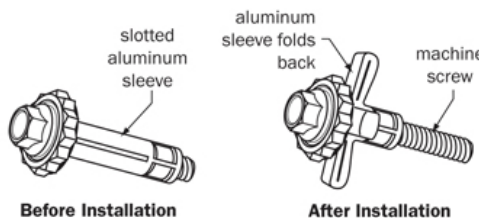

Galvanized Perforated Steel Square Sign Post

Known for superior strength and a geometry that allows signage to be mounted in 4 different directions, square posts have become a common choice for many municipalities.

SKU	SIZE
SPSQ10	1 3/4" x 10'
SPSQ12	1 3/4" x 12'
SPSQ3	2" x 3' **

**Breakaway



U-Channel Sign Post

U-channel posts are the most common post used throughout the United States. They are also one of the most economical choices for a sign mounting post. U-channel posts are available in both green and galvanized.

SKU	BASE
U-6-1LB*	6'
U-6*	6'
U-8-1LB*	8'
U-8*	8'
U-8-GALV**	8'
U-10*	10'
U-10-GALV**	10'
U-12*	12'
U-12-GALV**	12'

* Color = Green

** Galvanized



Plastic Caps



All stocking post caps are designed to be used with aluminum square posts. They can be used with wooden posts but adjustments will need to be made.

SPECIFICATIONS		
SKU	NAME	DESCRIPTION
4CAP/BALL	Ball	4" Slide Over
4CAP/BRIDGEPORT**	Bridgeport	4" Slide Over
4CAP/CLS	Classic	4" Slip Over
4CAP/CLS-NE	Classic New England	4" Slide Over
4CAP/COACHMAN	Coachman	4" Slide Over
4CAP/FEDERATION**	Federation	4" Slide Over
4CAP/GTH	Gothic	4" Slide Over
4CAP/PYD-OVER	Over Pyramid	4" Slide Over
4CAP/PYD	Internal Pyramid	4" Slip In
6CAP/BRIDGEPORT**	Bridgeport	6" Slide Over
6CAP/FEDERATION**	Federation	6" Slide Over
6CAP/HAMPTON*	Hampton	6" Slide Over
6CAP/HORSE*	Horse	6" Slide Over
6CAP/PRINCETON*	Princeton	6" Slide Over
SQR-2-10-14-WHT	Internal Flat Plug (white only)	2" Slip In
SQR-100MM	Internal Flat Plug (black only)	4" Slip In



* Style only available in 6 Inch
** Style available in both 4 inch & 6 inch

PREMADE PRODUCTS

POST CAPS

Aluminum Caps



Pyramid
2" Slide Over



Pyramid
4" Slide Over



Ball
2" Slide Over



Ball
4" Slide Over

SKU	NAME	DESCRIPTION
18-807-D	Pyramid	2" Slide Over
18-809-D	Pyramid	4" Slide Over
18-118-ALD	Ball	2" Slide Over
18-119-ALD	Ball	4" Slide Over

All Aluminum caps are manufactured with 1/8" thick aluminum with a gloss white powder coat finish.

Duracap High Density Urethane Post Cap



3 1/4" Acorn Post Cap
with mounting lag screw.



3 3/8" Ball Post Cap
with mounting lag screw.



Flat Bevel
4" Edge Post Cap



Flat Ogee
4" Edge Post Cap

SKU	NAME	DESCRIPTION
4-51A6	Acorn Post Cap	3 1/4" Mounting Screw
4-51A1	Ball Post Cap	3 3/8" Mounting Screw
51F1B	Flat Bevel Edge Post Cap	4" Slide Over
51F10	Flat Ogee Edge Post Cap	4" Slide Over

Create Your Own Post Cap Combination

Visit our website for "Sign Post Cap Ideas".

Steel Post Cap

*Steel post cap designed to be used with 2 3/8" round galvanized steel posts. *see page 68*



SKU: PC238AD-STEEL

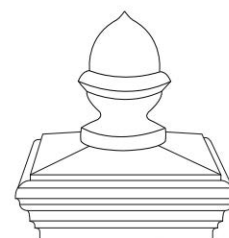
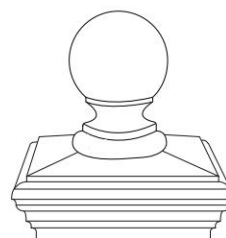

Carvagio HDU Blanks

Carvagio Sign Blanks are created for America's towns & historic districts. Carvagio blanks are pre-primed white single face and are manufactured from cast high density urethane. HDU will not rot, warp, crack or split even after prolonged outdoor exposure. For best results, use high quality latex or oil based paints as a top coat. All HDU blanks are sold without graphics and can be carved, routed & gold leafed. **ALL HDU blanks are SPECIAL ORDER only.**

Madison Presidential Collection

Graphic Area: 54"x44"



SKU	SIZE
M-59x49	59" x 49" x 3.5"

Yorktown Plaque

Graphic Area: 19"x26"



SKU	SIZE
Y-21X28	21" x 28" x 1.25"

Olde Towne Collection Classic Oval

Graphic Area: 15"x19"



SKU	SIZE
OT-19x23	19" x 23" x 1.5"

Jefferson Presidential Collection

Graphic Area: 54"x44"

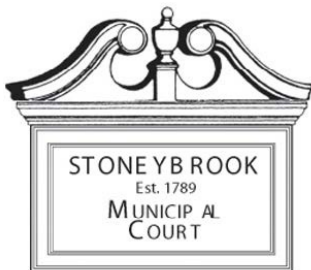

SKU	SIZE
J-59x49	59" x 49" x 3.5"

Savannah Rose Plaque

Graphic Area: 8"x11"



SKU	SIZE
SR-13x16	13" x 16" x 1.50"

Olde Towne Collection Banner

Graphic Area (Med): 5"x36"

Graphic Area (Lg): 9"x55"



Medium



Large

SKU	SIZE
OT-9x40	9" x 40" x 1.5"
OT-13x59	13" x 59" x 1.5"

Washington Presidential Collection

Graphic Area (Med): 54"x39"

Graphic Area (Lg): 54"x47"

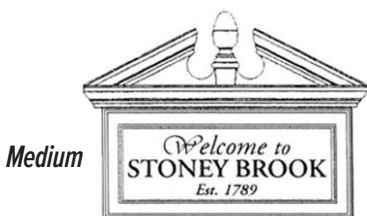

Medium

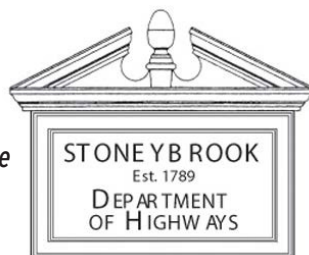

Large

SKU	SIZE
W-59x44	59" x 44" x 3.5"
W-59x52	59" x 52" x 3.5"

Olde Towne Collection Tablet

Graphic Area (Med): 25"x21"

Graphic Area (Lg): 37.5"x23.5"



Medium

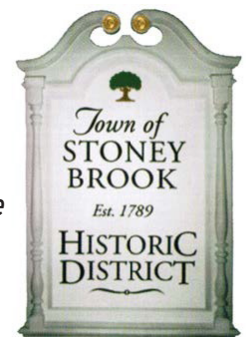

Large

SKU	SIZE
OT-30x26	30" x 26" x 3.5"
OT-40x26	40" x 26" x 3.5"

PREMADE PRODUCTS

HDU BLANKS

Oakwood Oval Collection

Graphic Area (Sm): 5"x7"
 Graphic Area (Med): 8.5"x11.50"
 Graphic Area (Lg): 12"x23"x1.50"
 Graphic Area (XL): 30.75"x40.75"

Small



Medium



Large



Extra Large



SKU	SIZE
OO-9x11	9.5" x 11.5" x 1"
OO-13x16	13" x 16" x 1.50"
OO-12x23	12" x 23" x 1.50"
OO-33x43	33" x 43" x 3.5"

Mount Vernon Tablet Collection

Graphic Area (Sm): 7"x8"
 Graphic Area (Med): 15"x18"
 Graphic Area (Lg): 39"x26"

Small



Medium



Large



SKU	SIZE
MV-11x12	11" x 12" x 1.25"
MV-19x22	19" x 22" x 1.5"
MV-43X30	43" x 30" x 2"

Tablet Name Plates

Graphic Area: 3"x20"

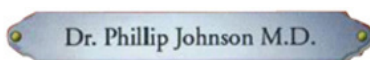

SKU	SIZE
TNP-3X22	3.5" x 22" x 1"

Annapolis Arch

Graphic Area: 37"x25"



SKU	SIZE
AA-42x30	42" x 30" x 3"

Princeton Peak

Graphic Area: 37"x27"



SKU	SIZE
PP-43x30	43" x 30" x 3.5"

Olde Towne Collection Classic Banner

Graphic Area: 6"x28"



SKU	SIZE
OT-7x32	7.5" x 32" x 1"

SignComp Sign Extrusion Kits

SignComp™ Vandal Systems

Single Faces & Double Face Slide Face System

- Provides the best vandal cover security system in the industry
- SAVE TIME with fast & easy assembly
- Inner hinge system allows system to be stacked or side hinged
- Outer doors easily hinge open using simple locking mechanism.
- The side retainers remove easily for service.
- Each kit comes complete with keys and locks
- Optional gas support allows customer to change messages without the worry of falling hinge frame.



Available Stocking Profiles

Vandal System: 2-Part 6" S/F Body
w/ 2-Part Inner & Outer Frame
(7" Depth)

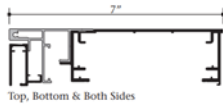

OF 1942 IF 1960 B 1926

Vandal System: 2-Part S/F Body
w/ 2-Part Inner & Outer Frame
(9" Depth)

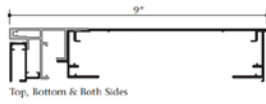

OF 1942 IF 1960 B 1926

Vandal System: 2-Part S/F Body
w/ 2-Part Inner & Outer Frame
(11" Depth)

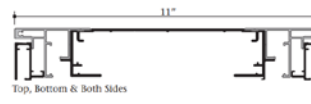

OF 1942 IF 1960 B 1928

Vandal System: 2-Part S/F Body
w/ 2-Part Inner & Outer Frame
(14" Depth)

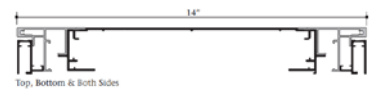

OF 1942 IF 1960 B 1929

SignComp™ Standard Rigid Systems

Single Faces & Double Face Slide Face System

Included in Sign Cabinet Kit Pricing

- Dark Bronze finish
- Three pieces of cut to size and mitered 1Part 12" Double Face Body, Part #1924
- One piece of cut to size and mitered 2Part 12" Double Face Body, Part #1929
- Two pieces of cut to size and mitered 2Part Retainer, Part #1944
- All screws required to assemble by mechanical fastening.
- All body corner angles and/or Corner Keys required.
- Packaging

Optional Accessories

- Pre-punched Raceways • Radius Corner • Divider Bar • Faces • Lamps • Ballast • LED • Aluminum Backer

Not Included in Sign Cabinet Kit Pricing

- Face or Backing • Divider Bar • Electrical Components • Ballast Bracket(s) • Back Braces and Gussets • Radius Corners



Available Stocking Profiles

1-Part 8" S/F Body & 2-Part S/F Body with
2-Part Retainer (8" Depth)

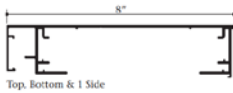

R-1944 B-1922

2-Part S/F Body with 2-Part
Extended Retainer (9" Depth)

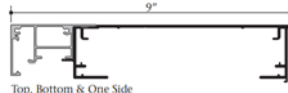

R-1940 B-1927

1-Part 9" Double Faced Body
(9" Depth)

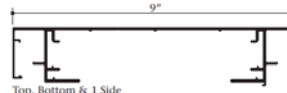

R-1944 B-1923

2-Part D/F Body with
2-Part Extended Retainer (14" Depth)

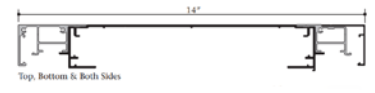

R-1940 B-1929

2- Part S/F Body with Retainer
All Around (8" Depth)

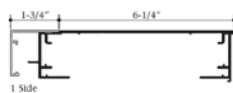

R-1944 RB-1927

1-Part 6" S/F Body
(6" Depth)

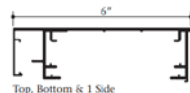

R-1944 B-1926 RB-1921

1-Part 12" Body
with 2-Part Retainer (12" Depth)



R-1944 B-1924 RB-1929

Why It's Important to use NEPCO for all your SignComp Kits

- Knowledgeable sales staff • Accurate saw cuts • Quick & accurate price quotes • NEPCO stocks a wide range of extrusion profiles
- 48 hour turn around times for most sign kits • Delivery service to RI, MA, CT, NH, ME & Albany, NY.

PREMADE PRODUCTS

EXTRUSION KITS

SignComp™ Commercial Rigid Systems

Single Face & Double Face Hingeable Rigid Face System

Now Offering with new 1 1/2" Retainer II. Allows face to be removed from one end

Included in Sign Cabinet Kit Pricing

- Cut to size and mitered body extrusion
- Cut to size and mitered retainers
- When using 2053 one vertical side will be 1 1/2" Frame with 1 1/2" cover to allow for sliding in and out the rigid plastic face.
- One vertical side will be dual frame with 2 1/4" dual frame cover to allow for sliding in and out of the rigid face.
- All screws required to assemble by mechanical fastening (note: Raceway Cover Screws are not included)
- All Body Corner Angles required
- All Corner Keys requires
- Packaging

Not Included in Sign Cabinet Kit Pricing

- Face or Backing • Divider Bar • Electrical Components • Ballast Bracket(s) • Back Braces and Gussets • Radius Corners



Optional Accessories

- Raceway Covers • Radius Corner
- Divider Bar • Faces • Lamps • Ballast
- Aluminum Backer

Available Stocking Profiles

Single Faced Body with NEW 1-1/2" II Retainer
(8-1/4" Depth)

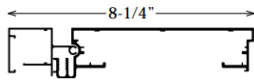

R-2053 B-2025

Medium Body with NEW 1-1/2" II Retainer
(11-3/4" Depth)

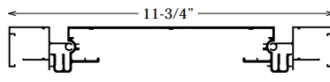

R-2053 B-2015

Wide Body with NEW 1-1/2" II Retainer
(15" Depth)

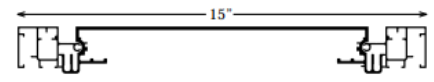

R-2053 B-2005

Single Faced Body with 2-1/4" Retainer
(9-1/4" Depth)

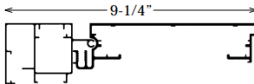

R-2045 DF-2065 DFC-2075 B-2025

Medium Body with 2-1/4" Retainer
(13-3/4" Depth)

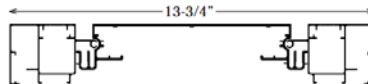

R-2045 DF-2065 DFC-2075 B-2015

Wide Body with 2-1/4" Retainer
(17" Depth)

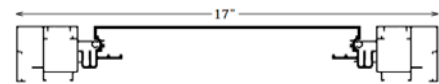

R-2045 DF-2065 DFC-2075 B-2005

SignComp™ EconoComp Rigid Face

Single Faces & Double Face Slide Face System

Included in Sign Cabinet Kit Pricing

- Dark Bronze finish
- Four pieces cut to size & mitered filler
- Cut to size & mitered retainers as needed
- All corner keys required
- All necessary screws
- Packaging

Not Included in Sign Cabinet Kit Pricing

- Face or Backing
- Divider Bar
- Electrical Components
- Ballast Bracket(s)
- Back Braces and Gussets
- Radius Corners - see optional accessories

Optional Accessories

- Raceway Covers • Radius Corner • Divider Bar • Faces • Lamps • Ballast • LED • Aluminum Backer



Available Stocking Profiles

Single Faced Filler with Econo Molding
(6 1/2" Depth)



R-2056 B-2034

Large Double Faced Filler with Econo Molding
(9" Depth)



R-2056 B-2032

Medium Double Faced Filler with Extended Econo Molding
(8" Depth)



R-2058 B-2036

Single Faced Body with Extended Econo Molding
(8" Depth)



R-2058 B-2034

Large Double Faced Filler with Econo Molding
(12" Depth)



R-2058 B-2032

Medium Double Faced Filler with Econo Molding
(5" Depth)

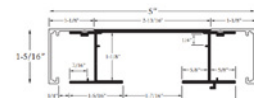

R-2056 B-2036

3 1/4" Post and Panel System Kits

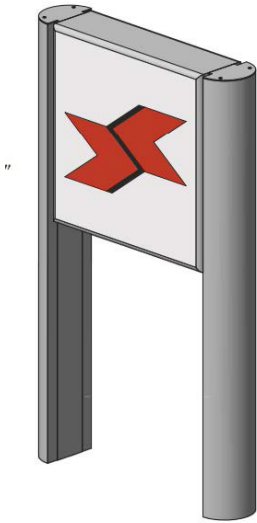

Body

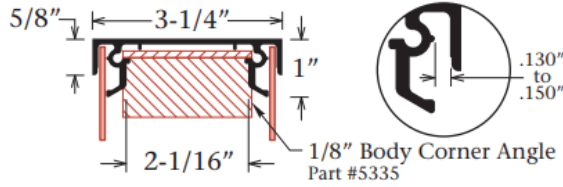

SKU Number: #1260
Part: Slide Body
 For Removable Faces



OPTIONAL POST

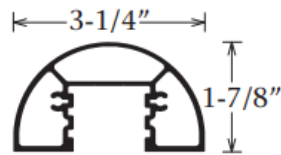
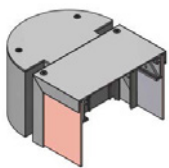

SKU Number: #1210
Part: Radius Post

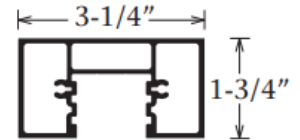
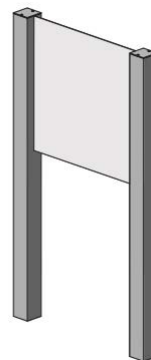

SKU Number: #1220
Part: Rectangular Post

SignComp Aerosol Matching Paint Bronze

Quaker Dark Bronze touch up paint for SignComp aluminum extrusion. Comes in a 12 oz. aerosol can.

SKU	SIZE
A-4679/BRONZE	12 oz



SignComp™ Channel Letter Raceway Bundles

Features & Benefits:

- New 1 Piece profile design.
- Intermediate screw boss added to accommodate ease of service access for LED power supplies.
- New Lifting Bracket
- Braces/Brackets can also be used to mount the power supply. (Allows for the required UL clearance off the bottom).
- Slide in mounting clips. (Top and Bottom).
- Drops can be easily joined/spliced together.
- Raceway and Cover can be cut at the same time.

1 Piece 5" Narrow Channel Letter Raceway with Cover

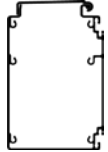

SKU Number: #B1970N
Finish: Mill Finish
Length: 24' 2"
Part: 5" Narrow Raceway & Cover
Not Included: Hardware, Brace/Brackets, Mounting Clips or End Caps

2 Piece 8" Narrow Channel Letter Raceway with Cover



SKU Number: #B1982
Finish: Mill Finish
Length: 24' 2"
Part: 2 PC, 8" Narrow Raceway & Cover
Not Included: Hardware, Brace/Brackets, Mounting Clips or End Caps

OPTIONAL HARDWARE



Optional 5" Narrow End Cap
SKU Number: #5987N



Optional Small Mounting Bracket
SKU Number: #1989-SMALL

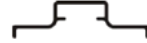

Optional Narrow Channel Letter Lifting
SKU Number: #1975N



Optional 8" Narrow End Cap
SKU Number: #5987N-8



Optional Large Mounting Bracket
SKU Number: #1989-LARGE

SignComp™ Socket Raceway II & Cover

Application examples for Button Type Sockets & Tombstone Type Sockets.

Using Button Type Socket

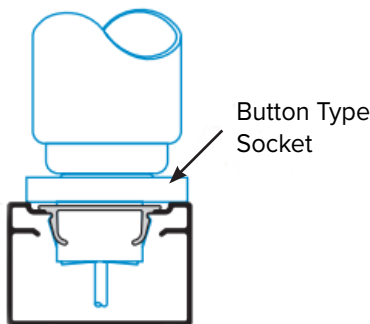

Using Tombstone Type Socket

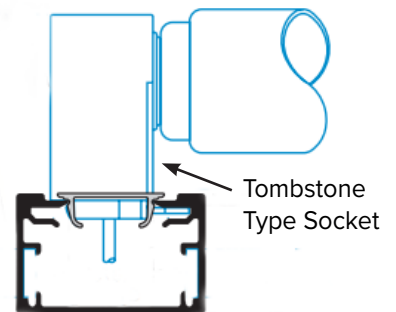
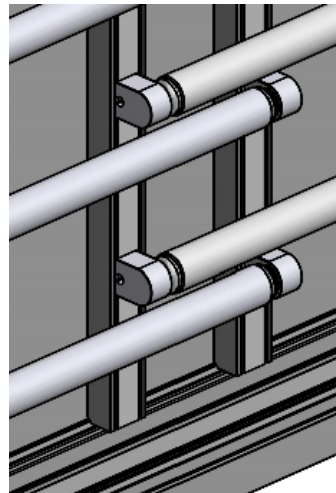

Aluminum Pop Rivet AA Series

Wide rivet range. Provides strong, low cost fastenings. Open-end rivets are ideal for a wide variety of applications.

SKU	RIVET SIZE	GRIP (D)	COLOR	QTY/BOX
A/A42D	1/8"	1/8"	Mill	1000/BOX
A/A42DBRZ	1/8"	1/8"	Bronze	1000/BOX
A/A42DW	1/8"	1/8"	White	1000/BOX
A/A43D	3/16"	1/8"	Mill	1000/BOX
A/A43DBLK	3/16"	1/8"	Black	1000/BOX
A/A43DBRZ	3/16"	1/8"	Bronze	1000/BOX
A/A43DW	3/16"	1/8"	White	1000/BOX
A/A44D	1/4"	1/8"	Mill	1000/BOX
A/A44DWHT #500	1/4"	1/8"	White	1000/BOX
A/A46D	3/8"	1/8"	Mill	1000/BOX
A/A48D	1/2"	1/8"	Mill	1000/BOX
A/A64D	1/4"	3/16"	Mill	1000/BOX
EA/A-66D	3/8"	3/16"	Mill	1000/BOX
EA/A-68D	1/2"	3/16"	Mill	1000/BOX
HA/A43LF**	3/16"	1/8"	Mill	100/BOX

**Large Flange

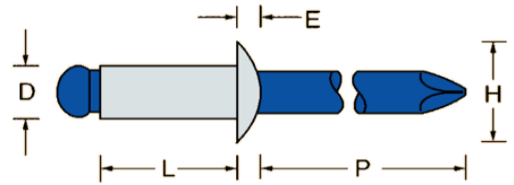

OTC Daihen Long Welding Tip

SKU	QTY	SIZE
U2075J07	10/Pack	.030 Tip



OTC Daihen Welding Wire

SKU	MATERIAL	SIZE
MB-4043-030	Aluminum	.030
MB-50-303	Mild Steel	.030

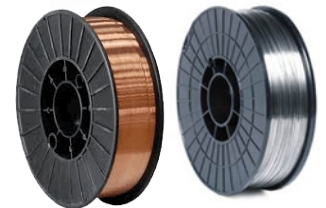

Small Clear Acrylic Block

Small Clear Acrylic Letter Mounting Blocks for use with #10-24 studs.

SKU	QTY	SIZE
PLA-BLOCKS	100/Bag	1/2" x 1/2" x 3/4"



Fully Threaded Aluminum Stud

Aluminum has a high strength-to-weight ratio and is wear resistant, nonmagnetic and conductive. It is easier to form and machine than steel and is naturally noncorrosive.

SKU	LENGTH	SIZE
4-STUDS	4 inch	3/16" 10/24 Thread
5-STUDS	5 inch	3/16" 10/24 Thread
6-STUDS	6 inch	3/16" 10/24 Thread
6-STUDS/1/4/20	6 inch	1/4" -20 Thread



Banner Stand Retractable Economy



The most economical retractable banner stand on the market. The Economy Retractable Banner Stand has a medium duty mechanism making it appropriate for temporary and full time displays or for advertising seasonal specials. This banner stand features a durable aluminum construction with a Black (**RU1332B-BLACK**) or Silver (**RU1332S**) finish. For easy storage, this economy banner stand and pole fold down into the base. When not in use, simply store the unit within the included bag to maintain the condition of the graphics and other components.

SKU	SIZE	ADJUSTABLE	VIEWABLE GRAPHIC SIZE	PRINTED GRAPHIC SIZE
RU1332B-BLACK	39.5" x 5.5" x 5.5"	NO	33.5" x 78.7"	33.5" x 84.7"
RU1332S	39.5" x 5.5" x 5.5"	YES	33.5" x 78.7"	33.5" x 84.7"

Banner Stand Retractable Premium Single-Faced Adjustable Height



The Premium Retractable Banner Stand System makes traveling from trade show to future customer easy. Take off the end caps, slide out the old print and put the new print, pull it up and done. Variable heights allow you to set on a table or on the floor without towering over your audience. Add Dye Sub print and a light and let the graphic do all the talking.

SKU	SIZE	ADJUSTABLE	VIEWABLE GRAPHIC SIZE	PRINTED GRAPHIC SIZE
RU13380S	33.5" x 11.5" x 5.5"	YES	33.5" x 61"- 86"	33.5" x 67"- 92"

You may also need...
Replacement Clip Top Rail & Replacement Poles
 Both are available upon request. Call to find out more.

Banner Stand X-Style Standard

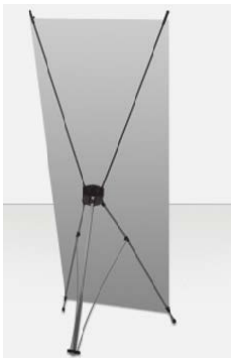

With its professional appearance and quick setup, the Standard X Banner Stand is a lightweight display that makes a great addition to any trade show exhibit. This lightweight display is made from fiberglass and plastic.

SKU	SIZE	ADJUSTABLE	VIEWABLE GRAPHIC SIZE	PRINTED GRAPHIC SIZE
XBS2423B	39.5" x 11.5" x 5.5"	N/A	24" x 63"	24" x 63"

Need Banner Material?
 See all stocking banner material on pages 19-20!

Lumina FDC 7604 Roll Up 13 oz • 1 Year • Super Smooth 1 Sided Printable

Blackout - 100%
 Eco-Solvent - Solvent - UV

Lumina 7604 Series is a scrimless non-curling 13 oz. PVC banner designed for printing pop-up or roll-up displays. It is a super smooth one side printable non-top coated media with a grey polyester back that provides opacity and obstructs light.

Recommended Use:

- Pop Up Displays
- Roll Up Displays

SKU	SIZE	COLOR
7604-38X40-049M	38" x 40YD	White Matte
7604-54X40-049M	54" x 40YD	White Matte



Pre Grommetted White Banner Material

The patented Bandanna Banner product is made from quality 14oz vinyl material and has thermo hemmed edges. The banners use a double grommet system with sets of 2 grommets spaced 3 inches apart. They also have a 'no-waste' system of grommets every 24 inches along the top and bottom of the banners. This system allows you to cut in between the two stainless steel grommets and not waste any material.

SKU	SIZE
2MATL/BF	22" x 24yds
3MATL/BF	34" x 24yds
4MATL/BF	45" x 24yds



Boulevard Banner Brackets

Boulevard Banners decorate your city streets, school campus or mall parking lots. Banner Brackets can attach to any light or street pole! Boulevard Banners serve the multiple purposes of attracting attention while adding atmosphere and delivering important information.

Each Boulevard Banner kit comes with:

- 2/ea Aluminum Brackets
- 2 3/4" Diameter Round Fiberglass Rods
- 2 Split Rings
- 2 Clevis Pins
- 2 Cable Ties
- 2 Rubber Caps
- 4/ea 47" Stainless Steel Straps



SKU	SIZE
BBK18	18 1/2" Boulevard Banner Kit
BBK24	24 1/2" Boulevard Banner Kit
BBK30	30 1/2" Boulevard Banner Kit
BBK36	36 1/2" Boulevard Banner Kit

Need an extra?

Boulevard Banner Bracket Strap

SKU: BBK-STRAP



#2 Grommet

3/8" self-piercing grommets. Can be used with our Hand Press Machines and/or our PRES-N-SNAP tool. Available in Brass and Nickel only. Bags of 500



SKU	FINISH
SPGW2N	Nickle
SPGW2B	Brass

Grommet Hand Press High Production

Free standing or bench mount hand press. Best quality. Deep throat. *Requires grommet die.

SKU
TEP-3



#2 Grommet Die Set

For #2 self-piercing grommets. Comes with #2 Rolling Die and #2 Anvil Die. 24 Line (9/16" 15mm) Snap dies are compatible with Dot, Fasnab, Rau, Ossian, Stocko, Vicar & YKK (Formerly Universal) Fasteners.

SKU	SIZE
GROM-DIE#2	9/16" (15mm)



Ace in the Hole Metal Grommets

3/8" Self piercing **extra long** barrel brass metal grommet. Bags of 500

SKU	FINISH
GRM2SPXLBB	Brass



ALUPANEL Standard - 0.30mm Aluminum Composite Material

Manufactured by UK-based MultiPanel, AluPanel is an Aluminum Composite Material manufactured with two .012" aluminum faces sandwiching a solid polyethylene core. (Compare to Dibond) The result is a lightweight, rigid signboard -- and we think it's the best one available! Tough polyester paint finish -- ONE SIDE GLOSS and ONE SIDE MATTE! Extensive range of finishes including metallic and mirror finishes. Both sides are masked for protection from handling damage. All AluPanel sheeting is designed to be digital printed.



SKU	DESCRIPTION - BLACK & WHITE	AVAILABLE SIZES			
		4' x 8'	4' x 10'	5' x 10'	5' x 12'
ALUWTXXXX	White Gloss/Matte - 3mm	✓	✓	✓	✓
ALUWTXXXX-6MM	White Gloss/Matte - 6mm	✓	✓	✓	
ALUBLKXXXX	Black Gloss/Matte - 3mm	✓	✓	✓	
ALUBLK4896-6MM	Black Gloss/Matte - 6mm	✓			
ALUDIGWT4896-8M	Ultrawhite Matte/Matte - 8mm	✓			



SKU	DESCRIPTION - COLORS	AVAILABLE SIZES	
		4' x 8'	5' x 10'
ALUBLUDKXXXX	Dk. Blue Gloss/Matte - 3mm	✓	✓
ALUBLULTXXXX	Lt. Blue Gloss/Matte - 3mm	✓	✓
ALUGRNDKXXXX	Dk. Green Gloss/Matte - 3mm	✓	✓
ALUGRNTREFXXXX	Lt. Green Gloss/Matte - 3mm	✓	
ALUIVYXXXX	Ivory Gloss/Matte - 3mm	✓	✓
ALUREDXXXX	Red Gloss/Matte - 3mm	✓	✓
ALUYLWXXXX	Yellow Gloss/Matte - 3mm	✓	✓



SKU	DESCRIPTION - METALLICS	AVAILABLE SIZES	
		4' x 8'	5' x 10'
ALUSILVMET4896	Silver Met. Gloss/Matte - 3mm	✓	
ALUBRHGLDEOP4X8	Brush Gold/Brush Copper - 3mm	✓	
ALUSILVMIR4896	Silver Mirror/Brush Copper - 3mm	✓	
ALUBRZDK4896	Dark Bronze/Matte - 3mm	✓	
ALUBURG4896	Burgundy Gloss/Matte - 3mm	✓	
ALUBRHALUMXXXX	Brush Alum./Silver Met. Matte - 3mm	✓	✓
ALUBRHALUM4X86M	Brush Alum./Silver Met. Matte - 6mm	✓	

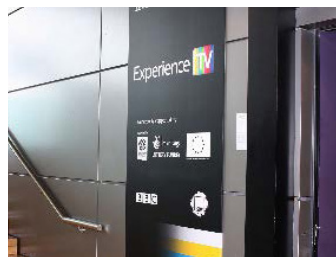
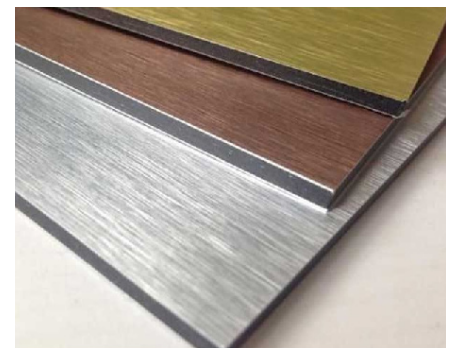

Beware of the aluminum composite panel imposters!
 Multipanel offers the widest selection for every purpose. Be sure to compare aluminum skin thicknesses as they do vary by manufacturers.

ALUPANEL LITE® - 0.21mm Aluminum Composite Material

Alupanel LITE® is a reduced weight aluminum composite panel with a matt/gloss dual sided finish, designed for use in advertising, sign making and other projects where high load-bearing capacity is not required. Available in one of the widest color ranges on the market, all standard PE colors come with a 5 year external guarantee.

SKU	DESCRIPTION - BLACK & WHITE	AVAILABLE SIZES		
		4' x 8'	4' x 10'	5' x 10'
ALU/LITEWTXXXX	White Gloss / Matte - 3mm	✓	✓	✓
ALU/LITEWT48-6M	White Gloss / Matte - 6mm	✓		
ALU/LITEBLKXXXX	Black Gloss / Matte - 3mm	✓	✓	✓

SKU	DESCRIPTION - COLORS	SIZE
ALU/LITEBLULT48	Lt. Blue Gloss / Matte - 3mm	4' x 8'
ALU/LITERED48	Red Gloss/Matte - 3mm	4' x 8'
ALU/LITEYLW48	Yellow Gloss/Matte - 3mm	4' x 8'



ECOPANEL Double Sided Economy - 0.15mm Aluminum Thickness

Providing amazing value for the money Alupanel®Eco is the obvious choice for short term projects where no load will be applied to the panels.

SKU	DESCRIPTION	SIZE
ALUECOSATWHT3M	White Satin / Satin - 3mm	4' x 8'

Only Available in White

GREAT FOR CUTTING INTO SIGN BLANKS!

EMAXX PANEL Single Sided Economy - 0.15mm Aluminum Thickness

EMaxx is a reduced weight aluminum composite panel with an ultra matte white on one side and a mill finish on the backside. Designed for use in single sided sign making & other projects where high load-bearing capacity is not required.

SKU	DESCRIPTION	AVAILABLE SIZES
ALUEMAXXXXXXXW	White Matte / Mill - 3mm	4' x 8' & 5' X 10'

MULTISHIELD - 0.25 mm Thickness Galvanized Steel

Both sides of the panel have a flat, smooth, uniform surface. Available coatings include a digital finish to help produce vibrant, color-fast prints, and a whiteboard coating, suitable for use with dry-wipe markers. Multishield® is available in either digital/digital or digital/whiteboard options. Ideal for hoarding panels, whiteboards, printing and many other applications, the galvanized steel provides additional strength plus the versatility of a magnetically receptive surface. Multishield® panels can be fabricated, are strong, self-supporting and offer outstanding reliability with the backing of a 5 year guarantee * for interior use.

SKU	DESCRIPTION	SIZE
ALUMSWTM/DRYE	Dry Erase Magnetic Board - 3mm	4' x 8'
ALUMSWTM/M48	Digital Print Magnetic Board - 3mm	4' x 8'



CELTEC Expanded PVC

VYCOM'S Celtec® Expanded PVC graphic and display materials are designed with a unique combination of features that make it ideal for digital screen printing, signage, exhibits, POP, and more. Vycom's PVC signage materials are lead and heavy metal free, which allows them to optimize performance while being environmentally friendly.



STANDARD WHITES		
SKU	DESCRIPTION	SIZE
PVC4896WT50	White with masking one side - 12mm	4' x 8' x 1/2"
PVC48120WT50	White with masking one side - 12mm	4' x 10' x 1/2"
PVC4896WT75	White with masking one side - 19mm	4' x 8' x 3/4"
PVC48120WT75	White with masking one side - 19mm	4' x 10' x 3/4"
PVC4896WT1	White with masking one side - 25mm	4' x 8' x 1"

VIVID WHITES FOR FLAT BED PRINTING		
SKU	DESCRIPTION	SIZE
FMW2-VIVWT	Vivid White without masking - 2mm	4' x 8' x 5/64"
FMW3-VIVWT	Vivid White without masking - 3mm	4' x 8' x 1/8"
FMW3-410-VIVWT	Vivid White without masking - 3mm	4' x 10' x 1/8"
FMW3-510-VIVWT	Vivid White without masking - 3mm	5' x 10' x 1/8"
FMW6-VIVWT	Vivid White without masking - 6mm	4' x 8' x 1/4"
FMW6-410-VIVWT	Vivid White without masking - 6mm	4' x 10' x 1/4"
FMW6-510-VIVWT	Vivid White without masking - 6mm	5' x 10' x 1/4"



STANDARD BLACKS		
SKU	DESCRIPTION	SIZE
FMBK3	Black without masking - 3mm	4' x 8' x 1/8"
FMBK6	Black without masking - 6mm	4' x 8' x 1/4"
PVC4896BK50	Black without masking - 12mm	4' x 8' x 1/2"
PVC4896BK75	Black without masking - 19mm	4' x 8' x 3/4"
PVC4896BK1	Black without masking - 25mm	4' x 8' x 1"

STANDARD COLORS		
SKU	DESCRIPTION	SIZE
FMBL3	Blue with masking one side - 3mm	4' x 8' x 1/8"
FMBL6	Blue with masking one side - 6mm	4' x 8' x 1/4"
FMGY3	Dk. Grey with masking one side - 3mm	4' x 8' x 1/8"
FMGY6	Dk. Grey with masking one side - 6mm	4' x 8' x 1/4"
FMLGY3	Lt. Grey with masking one side - 3mm	4' x 8' x 1/8"
FMR3	Red with masking one side - 3mm	4' x 8' x 1/8"
FMY6	Yellow with masking one side - 6mm	4' x 8' x 1/4"

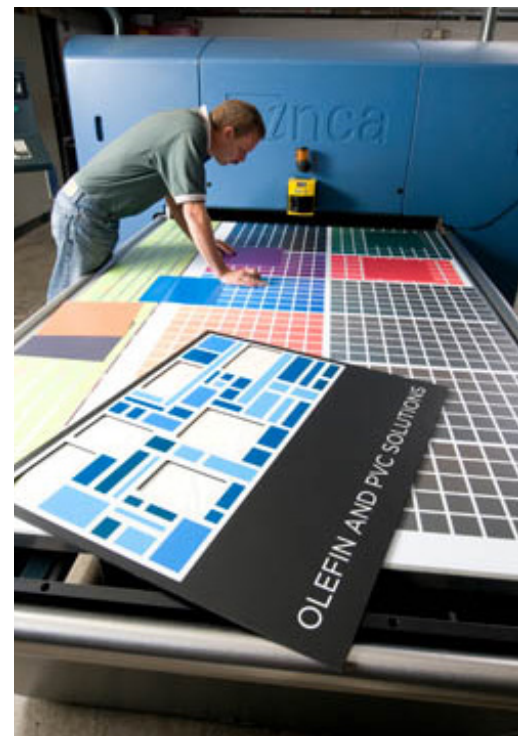

Integral (Smooth Hard Surface) PVC

Integral PVC IF is a chemically formed, light weight, rigid extruded sheet with a fine and homogeneous closed cell structure. It has a **smooth, glossy hard finish** on both sides and is non-corrosive making it suitable for both indoor and outdoor use.

Integral PVC IF is recommended for graphics applications including digital direct imaging, screen inks, lettering enamels, and vinyl graphics. Its great characteristics make it perfect for applications in many different industries, including construction, advertising, photographic, electrical, and more.

SKU	DESCRIPTION	SIZE
13MWT-INTEGRAL	White smooth hard surface PVC - 13mm	4' x 8' x ½"
19MWT-INTEGRAL	White smooth hard surface PVC - 19mm	4' x 8' x ¾"

Helpful Tip!

*Expanded PVC should be cleaned with isopropyl or denatured alcohol and wiped thoroughly in one direction. Human hands contain oils and acids that alter the characteristics of **ALL** substrates. Oils and acids can potentially affect adhesion of vinyls, inks and paints. All personnel that handles PVC sheeting should always wear clean cotton disposable gloves. *see page 101**

MULTIPANELUK[®] PVC

Multipanel PVC sheets are made using the free foam extrusion process. A lightweight brilliant white panel, they have a flat, smooth, uniform surface which gives optimum ink adhesion to produce vibrant, color-fast prints. Their rigidity, fine cell structure and smooth surface makes our PVC boards the preferred choice for professional printers, sign makers and exhibition contractors throughout the world. Designed for printing and other flat applications, Multipanel PVC offer outstanding reliability and performance creating excellent results time after time.

Features & Benefits:

- Masked on one side
- 550 & 600 Density
- Strong and Durable
- Anti-Bacterial
- Ultra White/Black
- Fire Resistant
- 100% Recyclable
- Anti-static Properties
- Weather and UV Stability
- Lightweight yet rigid
- Will not warp, delaminate, cup or twist
- Thermal and Sound Insulating
- Excellent for flat bed printing
- Can be used indoors or outdoors

SKU	SIZE	DENSITY	COLOR
PVCW3-600	4'x 8'x ⅛"	600	White
PVCW6-600	4'x 8'x ¼"	600	White
PVCW12-550	4'x 8'x ½"	550	White
PVCB3-600	4'x 8'x ⅛"	600	Black
PVCB6-600	4'x 8'x ¼"	600	Black
PVCB12-550	4'x 8'x ½"	550	Black



Helpful Tip!

Chromatic Universal Acrylic Primer is a fantastic choice for priming Expanded PVC.

SUBSTRATES

ALUMINUM CORRUGATED POLYPROPYLENE



Single Face Aluminum - Corrugated Plastic Core

Econolite is a strong, aluminum composite panel with a high-density corrugated polyallomer (CPA) core that will not swell, corrode, rot, wick water, or delaminate even under prolonged water exposure. Econolite panels also feature a single-sided, finished surface of high-gloss factory baked polyester painted aluminum. Each panel is also backed with an unpainted aluminum sheet for added balance. The painted surface is warranted not to crack, chip, flake, or peel. Econolite panels are field-tested through extensive freeze/thaw cycling tests with no significant structural panel failure.

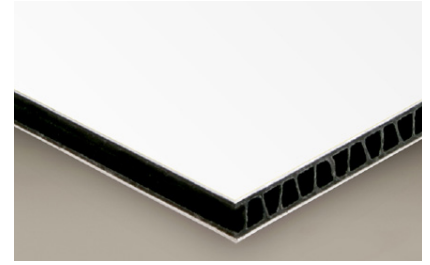

Features:

- Econolite has all the benefits of Alupalite but with only **1 finished aluminum side**; Alupalite has 2 finished sides
- Ideal for paints, digital inks (both UV or solvent cured), screen print inks, and pressure-sensitive vinyl

SKU	SIZE	COLOR
EL-WHT-C48YWGN	4' x 8' x 1/4"	White
EL-BLU-C48AAGN	4' x 8' x 1/4"	Blue
EL-BLK-C48BRGN	4' x 8' x 1/4"	Black
EL-GRN-C48CBGN	4' x 8' x 1/4"	Green

- Strong and lightweight
- Routs and cuts easily using standard carpentry tools
- Wind-resistant - when properly fastened between two post Econolite can withstand winds over 120 mph
- Weather-resistant with a "Class A" flame spread rating.
- The surface is formulated to resist outdoor dirt and is practically "self-cleaning".



Alupalite

Alupalite is a strong, aluminum composite panel with a high-density corrugated polypropylene core that will not swell, corrode, rot, wick water, or delaminate even under prolonged water exposure. The factory-baked polyester painted aluminum faces add high gloss brilliance and rigidity and are warranted not to crack, chip, flake, or peel. Field-tested through extensive freeze/thaw cycling tests with no significant structural panel failure. Routs and cuts easily using standard carpentry tools; even bends around corners. Wind-resistant—when properly fastened between two posts, Alupalite can withstand winds over 120 mph Alupalite offers a colorfast 10 year limited warranty. It's ideal for paints, digital inks (both UV or solvent cured), screen print inks, and pressure-sensitive vinyl.

Recommended Applications:

- General Signage • Architectural Signage • Digital Print • Post & Panel Signs
- Real Estate • Dimensional Letters / Cut-outs • POP Displays & Exhibits

SKU	SIZE	DESCRIPTION
AL-WHT-C48YWYW	4' x 8' x 1/4"	White Double-Face
AL-WHT-C40YWYW	4' x 10' x 1/4"	White Double-Face
AL-WHT-C50YWYW	5' x 10' x 1/4"	White Double-Face

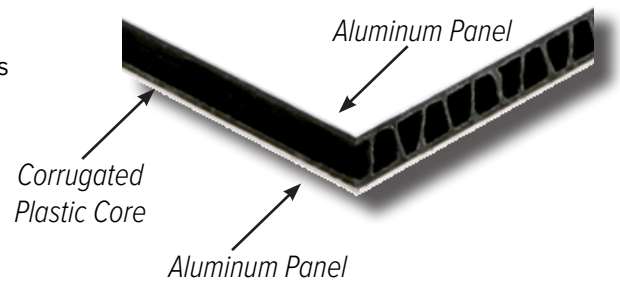

PVC Edge Caps

These durable edge caps definitely will give life to the perimeter of your signs, giving them a smooth and professional look. This short edge cap also makes it easy to conform to any letter! Choose from a variety of attractive colors to accent the perimeter of your sign.

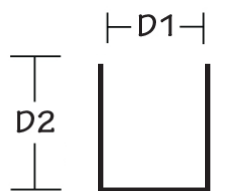

Thickness:
(0.030")

SKU	LENGTH	D1	D2	COLOR
50199-98/BLK	98'	1/4"	1/4"	Black
50203-98/BLK	98'	1/2"	1/2"	Black
50200-98/WHT	98'	1/4"	1/4"	White
50230-98/WHT	98'	3/8"	3/8"	White
50201-98/WHT	98'	1/2"	1/2"	White
50226-98/WHT	98'	3/4"	3/4"	White
50208-98/BLU	98'	1/4"	1/4"	Blue
50217-98/BLU	98'	1/2"	1/2"	Blue
50230-98/RED	98'	1/4"	1/4"	Red
50231-98/RED	98'	1/2"	1/2"	Red
50229-98/GRN	98'	1/2"	1/2"	Green

Coroplast® Corrugated Plastic Sheeting

Features & Benefits

- No warping or bowing
- Square cut
- Consistent color
- Superior Protective Packaging
- Consistent flute size throughout
- Corona treated two sides



SKU	SIZE	COLOR
CORA-BLK	4' x 8' x 4mm	Black
CORA-BLUE	4' x 8' x 4mm	Blue
CORA-BLUE-DK	4' x 8' x 4mm	Dark Blue
CORA-BLUE-NAVY	4' x 8' x 4mm	Navy Blue
CORA-GREEN	4' x 8' x 4mm	Green
CORA-IVORY	4' x 8' x 4mm	Ivory
CORA-ORANGE	4' x 8' x 4mm	Orange
CORA-RED	4' x 8' x 4mm	Red
CORA-WHT	4' x 8' x 4mm	White
CORA-WHT-10MM	4' x 8' x 10mm	White
CORA-WHT-4X10	4' x 10' x 4mm	White
CORA-WHT-5X10	5' x 10' x 4mm	White
CORA-WHT-6MM	4' x 8' x 6mm	White
CORA-WHT-OPAQUE	4' x 8' x 4mm	White Opaque
CORA-YEL	4' x 8' x 4mm	Yellow

Beware! Competitive manufacturers don't always offer square cut and corona treatment, which promotes surface adhesion on corrugated sheeting.

Coroplast Blanks ALL BLANKS ARE TRIMMED AND SQUARED

The most economical substrate-perfect for yard signs and other temporary signage- limited exterior life. Used extensively for indoor and outdoor signage, display panels, real estate & election signs, shipping containers, packaging, and architectural modeling. Can be grommetted, mounted in sign frames, or supported with Step-Stakes.

SKU	SIZE	COLOR
CORA-BLK-36X24	36" x 24" x 4mm	Black
CORA-WHT-24X18	24" x 18" x 4mm	White
CORA-WHT-36X24	36" x 24" x 4mm	White
CORA-WT-OPQ2418	24" x 18" x 4mm	White Opaque
CORA-YEL-24X18	24" x 18" x 4mm	Yellow
CORA-YEL-36X24	36" x 24" x 4mm	Yellow

Buy any combination of 100 or more Step Stakes / Coroplast Blanks & receive additional discounts!

Styrene Sheet & Blank

High-Impact Matte Finish and 1-Year Exterior Life.

SKU	SIZE	COLOR
STY/48/040/WHT	4' x 8' x .040	Styrene Sheet - White
STY/48/060/WHT	4' x 8' x .060	Styrene Sheet - White
STY/48/080/WHT	4' x 8' x .080	Styrene Sheet - White
STY-PLASTICADE	23 3/4" x 35 3/4" x .040	Styrene Blank - White

Need an Inexpensive Blank for your Signicade?

*NEPCO offers pre-cut 23 3/4" x 35 3/4" x .040 white styrene blanks. *see page 63-64*

SUBSTRATES

POLYCARBONATE



Sign Grade Polycarbonate Cut to Length Reels

Tuffak® SL Sign Grade polycarbonate sheet, available in sheet and reel, is an enhanced UV resistant product with exceptional weatherability and superior impact strength. Available in clear or white, and SL Matte, Tuffak® SL polycarbonate meets UL 879 for electrical signage. Tuffak® SL can be easily fabricated, thermoformed, and decorated, and has a proven track record of

DESCRIPTION	SKU	SIZE - CUT TO LENGTH
2' White	L-POLY2W177	3/16" thick roll x 30" min. width
3' White	D-POLY3W150	5/32" thick roll x 40" min. width
4' White	A-POLY4W177	3/16" thick roll x 52" min. width
4' White	B-POLY4W118	1/8" thick roll x 52" min. width
4' Clear	F-POLY4CC177	3/16" thick roll x 52" min. width
4' Clear	E-POLY4CC118	1/8" thick roll x 52" min. width
6' White	H-POLY6W177	3/16" thick roll x 76" min. width
6' Clear	J-POLY6CC177	3/16" thick roll x 76" min. width
5' White	C-POLY5W177	3/16" thick roll x 64" min. width
8' White	I-POLY8W177	3/16" thick roll x 100" min. width

outstanding performance in any environment. With Tuffak® SL and Tuffak SL Matte polycarbonate sign grade products, you can be confident your company image is secure.

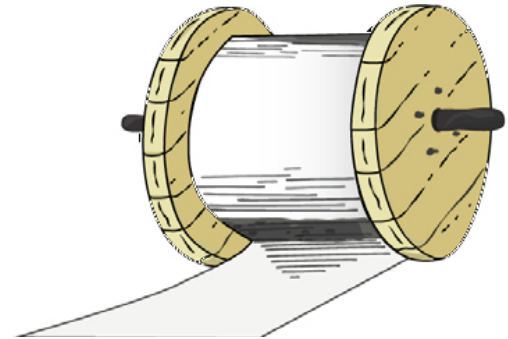

Printable Polycarbonate Film Roll

This film is extremely versatile film used in broad range of applications: instrument panels, trade show displays, membrane switches, control panels and decals. They offer excellent light-diffusing characteristics, NON UV and chemical resistance and other proven properties. Typical applications are automotive, labels, control panels, membrane switches, nameplates, light diffusion, packaging and automotive interior decoration. Tuffak PC VM is available in various standard thicknesses from 0.005 to 0.030 (125 microns to 750 microns). The surface combination of Tuffak PC VM is one side velvet and one side matte.

Recommended Applications:

- General Signage • Marine • Displays • Instruments • Glazing • Automotive

DESCRIPTION	SKU	SIZE
Film Roll, Clear Velvet Matte	PCVM/25	48" x 25' x .020



General Purpose Polycarbonate Sheet

Solid Tuffak® GP sheets are clear, polished, UV-stabilized polycarbonate sheets. They offer extreme impact strength that exceeds the physical properties of other products of their class. Tuffak® sheets resist temperatures of -100 to +120 C, exhibit high optical clarity and have a good fire rating.

DESCRIPTION	SKU	SIZE
GP Polycarbonate Sheet, Clear	48/060/CLR/POLY	48" x 96" x .060"
GP Polycarbonate Sheet, Clear	48/080/CLR/POLY	48" x 96" x .080"

Vacuum Formed PAN Faces

Pan faces are formed with 10 year White or Clear TUFFAK sign grade Polycarbonate. Pan faces are an excellent alternative to standard flat faces. The face is vacuum formed to a depth of 2.25" which brings the surface further away from fluorescent lamps than a standard flat face. The added depth allows for better light diffusion and can sometimes eliminate hot and cold spots that are seen when lamps are mounted too close to a flat face. Pan faces are available in all standard sizes that range from 12"x24" to 48"x120". Larger sizes can be ordered as TWO PIECE. Custom sizes, radius corners and embossed pan faces are also available.



Call today for a quote!!

Acrylic Sheeting

General Purpose Acrylic Sheeting is durable, weather-resistant and lightweight for easy transport and storage. It also offers a high molecular weight for ease of fabrication, low heat loss for economy & an attractive clear edge color. It also is recognized as a cast acrylic, with film.

SKU	SIZE	COLOR
48/3M/2025BKA	4' x 8' x 1/8"	Black
48/4.5M/2025BKA	4' x 8' x 3/16"	Black
48/.220/2025BKA	4' x 8' x 1/4"	Black
48/.500/2025BKA	4' x 8' x 1/2"	Black

SKU	SIZE	COLOR
48/3M/7328WTA	4' x 8' x 1/8"	White
48/4.5M/2447WTA	4' x 8' x 3/16"	White
48/4.5M/7328WTA	4' x 8' x 3/16"	White
48/.220/7328WTA	4' x 8' x 1/4"	White
48/.500/7328WTA	4' x 8' x 1/2"	White
410/4.5M/7328WA	50" x 120" x 3/16"	White

SKU	SIZE	COLOR
48/4.5M/2283RDA	4' x 8' x 3/16"	Red
48/4.5M/2793RDA	4' x 8' x 3/16"	Red
48/4.5M/2037YWA	4' x 8' x 3/16"	Yellow
48/4.5M/2051BLA	4' x 8' x 3/16"	Blue



SKU	SIZE	COLOR
48/3M/CLR-A	4' x 8' x 1/8"	Clear
48/4.5M/CLR-A	4' x 8' x 3/16"	Clear
48/.220/CLR-A	4' x 8' x 1/4"	Clear
48/.375/CLR-A	4' x 8' x 3/8"	Clear
48/.500/CLR-A	4' x 8' x 1/2"	Clear
48/.750/CLR-A	4' x 8' x 3/4"	Clear
48/.236/CLR3030	4' x 8' x 1/4"	Green Edge
48/.500/CLR3030	4' x 8' x 1/2"	Green Edge

Specialty Acrylic

P95 Acrylic Sheet has a matte finish that reduces reflected light. The perfect choice for displays hot-stamping, silk-screening, & vinyl sign-making. Use the sheet for privacy windows, pantry and cupboard doors. It can be used for residential, commercial, industrial & professional applications. The P95 sheets can be fabricated without altering the optical or mechanical properties of the product.

SKU	DESCRIPTION	SIZE
48/3M/CLR/P95	1/8" Thick Clear Matte Acrylic Sheet	4' x 8' x .118
48/.220/CLR/P95	1/4" Thick Clear Matte Acrylic Sheet	4' x 8' x .220
48/.500/CLR/P95	1/2" Thick Clear Matte Acrylic Sheet	4' x 8' x .500
48/3M/2025BKP95	1/8" Thick BLACK Matte Acrylic Sheet	4' x 8' x 1/8"
48/3M/7328WTP95	1/8" Thick WHITE Matte Acrylic Sheet	4' x 8' x 1/8"



P99 Acrylic Sheet non-glare sheet is designed to minimize glare and reflection and maximize the unhindered viewing of framed artwork and prints. Lightweight, easily fabricated and can be painted or silk-screened for a variety of applications. The non-glare is also available with UV filtering properties.

SKU	DESCRIPTION	SIZE
48/060/CLR/NG	1/16" Thick Clear Non-Glare Acrylic Sheet	4' x 8' x .060
48/3M/CLR/NG	1/8" Thick Clear Non-Glare Acrylic Sheet	4' x 8' x 1/8"
48/.220/CLR/NG	1/4" Thick Clear Non-Glare Acrylic Sheet	4' x 8' x .220

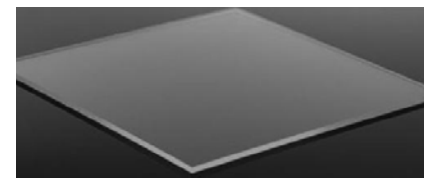



Scooter Board

Pre-finished Ready-to-Go Hardboard - Scooter Board is moisture resistant and weighs 1/3 less than high-density hardboards. It has a brilliant white finish that is stain resistant and tougher than roller-coated applied paints. Solid 1/2" core and is great for outdoor short-term signage. Vinyl and UV print receptive and is perfect for routing and cutting.

SKU	DESCRIPTION	SIZE
SB-48X96X1/2-UV	White/White	4' x 8' x 1/2"



Lusterboard

Lusterboard has a hardwood core and is composed of a premium, exterior furniture-grade plywood, featuring smooth, tight, sanded veneers for optimum surface beauty. Lusterboard has factory-baked polyester painted aluminum surfaces that covers both sides of the hardwood core, creating a smooth, glossy finish. Lusterboard is great for Cut-Outs, Billboards, Scoreboards and much more! Light, yet rigid construction, allowing for easier handling and installation. Lusterboard's surface is warranted not to fade, flake, or peel. Easy to fabricate with standard carpentry tools.

SKU	DESCRIPTION	SIZE
LB-H48BWBW	Lusterboard - White	4' x 8' x 1/2"
LB-H40BWBW	Lusterboard - White	4' x 10' x 1/2"



MDO (Medium Density Overlay)

Plum Creek MDO 2 step process overlaid, hardwood faced plywood with tight core for superb machinability and weatherability.

Features & Benefits:

- Tightly laid core for excellent machinability
- High strength, light weight
- Excellent for flat signage and cut out letters
- Long term smooth surface for paint and coatings
- Very low formaldehyde

SKU	DESCRIPTION	SIZE
GS-2 1/2-PRIME	Double Face 5-ply - Primed	4' x 8' x 1/2"
GS-2-75-PRIME	Double Face 2-step 7-ply - Primed	4' x 8' x 3/4"
GS-2-75-10	Double Face 7-ply - Natural	4' x 10' x 3/4"



Treated Wood Composite Panel

Can be routed, carved or sandblasted.

Tough and Revolutionary Performance in Exterior Environments! Sanded two sides (S2S) for a smooth, unprimed surface. Moisture, rot and termite resistant. No added urea formaldehyde; made from sustainable materials. One piece solid substrate - not laminated. Moisture resistant: As measured by ASTM D1037 for water absorption and thickness swelling. Rot resistant: As measured by AWP A E-16 Field Test for Evaluation of Wood Preservatives To Be Used Out of Ground Contact: Horizontal Lap-Joint Method. Termite resistant: As measured by AWP A E-7 Standard Method of Evaluating Wood Preservatives by Field Tests with Stakes. 5-year limited warranty!

SKU	DESCRIPTION	SIZE
EXT4X8X75	Treated Wood Composite	4' x 8' x 3/4"
EXT4X8X1	Treated Wood Composite	4' x 8' x 1"
AVAILABLE FOR SPECIAL ORDER*		
EXT2X16X75*	Treated Wood Composite	2' x 16' x 3/4"
EXT4X16X1.25*	Treated Wood Composite	4' x 16' x 1 1/4"
EXT4X16X75*	Treated Wood Composite	4' x 16' x 3/4"
EXT4X8X.5*	Treated Wood Composite	4' x 8' x 1/2"
EXT4X8X1.25*	Treated Wood Composite	4' x 8' x 1 1/4"

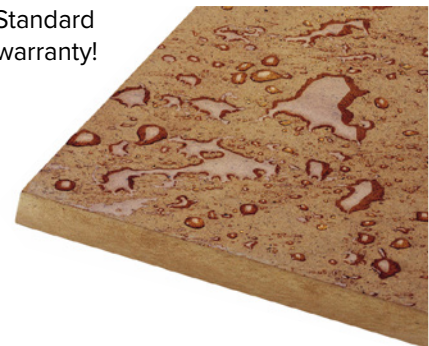



High Density Urethane Sheeting

Discover SignFoam4, the ultimate artist's sign board for dimensional signage and displays. Available in 15lb. and 18lb densities, this next-generation material provides the crisp, clean edges and detailed definition that you demand – plus so much more. Its advanced microcell technology produces an exceptionally fine, grain-free surface that minimizes sanding, and greatly reduces priming, painting and finishing time. Imagine, ultra-smooth painted finishes with fewer coats and less process labor. SignFoam4's tough-yet-refined cell structure accommodates virtually any design you envision, whether milled by machine, carved by hand, or sandblasted. It's a superb board for CNC-machining finely detailed designs and lettering, and nearly invisible surface textures. The advantages of SignFoam4's tighter microcell texture include:

- Boards that are easier to machine
- Faster, more precise hand carving
- Crisper, cleaner, stronger edges
- Less filling, sanding, priming and painting
- Finer, more intricate 3-D details
- Greater endurance in outdoor applications
- Excellent small-shape durability
- Wood-like shavings vs. dust when machining
- Ultra-smooth surfaces with less work

4'x8'x3" (15lb)

BACK BY POPULAR DEMAND & NOW STOCKING.

SKU: SF4-15-3-4X8



**Magnum
Magnetics**

Magnetic Sheeting

All ProMAG® Magnetic Sheeting is available in standard magnetic strength. Our magnetic sheeting can be magnetized single sided or double sided for thickness above .030". This high-quality magnetic material can be coiled to a 1/2" (12.7 mm) radius without cracking at 68 F. The performance range for temperature is -15 F to 160 F (-26 C to 71 C). With thicknesses ranging from .015" to .060", the wide range of thicknesses available in ProMAG magnetic sheet can be your competitive edge. ProMAG is available with several colored vinyl laminates: Matte white, black, blue, yellow, gloss white, red and green. ProMAG is available in both rolls and sheets. ProMAG magnetic sheeting is magnetized with equally spaced magnetic poles running parallel to the length of the rolls.



SKU	DESCRIPTION	SIZE
25AFG028243701	Printable Roll - White	24" X 25' X 0.30mil
50AFG028243701	Printable Roll - White	24" X 50' X 0.30mil

Helpful Tip!

- To guard against moisture and dirt buildup between the magnet and the metal surface (particularly on outdoor applications), remove the magnet at regular intervals.
- Clean both the magnet and metal surface with mild detergent; wipe with a soft cloth or allow to air-dry. (For vehicle-mounted signs, remove and clean DAILY.)
- After waxing and polishing, allow 2 days for wax to cure before applying magnets.



SKU	SIZE	DENSITY
SF4-15-75-2X8	2' x 8' x 3/4"	15 lb.
SF4-15-1-2X8	2' x 8' x 1"	15 lb.
SF4-15-1.5-2X8	2' x 8' x 1 1/2"	15 lb.
SF4-15-2-2X8	2' x 8' x 2"	15 lb.
SF4-15-75-4X8	4' x 8' x 3/4"	15 lb.
SF4-15-1-4X8	4' x 8' x 1"	15 lb.
SF4-15-1.5-4X8	4' x 8' x 1 1/2"	15 lb.
SF4-15-2-4X8	4' x 8' x 2"	15 lb.
SF4-15-75-4X4	4' x 4' x 3/4"	15 lb.
SF4-15-1-4X4	4' x 4' x 1"	15 lb.
SF4-15-1.5-4X4	4' x 4' x 1 1/2"	15 lb.
SF4-15-2-4X4	4' x 4' x 2"	15 lb.
SF4-15-3-4X8	4' x 8' x 3"	15 lb.
SF4-15-1.5-4X10	4' x 10' x 1 1/2"	15 lb.
SF4-15-2-4X10	4' x 10' x 2"	15 lb.
SF4-15-2-5X8	5' x 8' x 2"	15 lb.
SF4-15-1.5-5X10	5' x 10' x 1 1/2"	15 lb.
SF4-15-2-5X10	5' x 10' x 2"	15 lb.
SF4-18-1-4X8	4' x 8' x 1"	18 lb.
SF4-18-1.5-4X8	4' x 8' x 1 1/2"	18 lb.
SF4-18-2-4X8	4' x 8' x 2"	18 lb.

ENCORE Foam Boards - Limited Rigidity

Features & Benefits

- Limited rigidity & least expensive of ALL Encore sheeting
- Clay coated paper surface available in black or white
- Digital & silk screen receptive
- Tough, yet pliable polystyrene core

Applications

- Digital imaging • Exhibits • Laminating • Litho mounting • Painting • Signs
- Air brushing • POP displays • Models • Vinyl lettering • Screen printing

Fabrication

- Machine cutting • Die cutting • Embossing • Hand cutting • Scoring

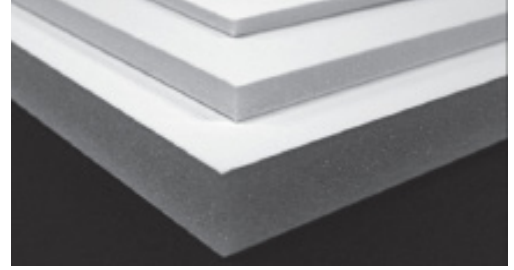

SKU	DESCRIPTION	SIZE
ENCOREBK4812	Black-On-Black® Foam Board	4' x 8' x 1/2"
ENCOREBK48316	Black-On-Black® Foam Board	4' x 8' x 3/16"
ENCOREEXT4812	Extreme White Foam Board®	4' x 8' x 1/2"
ENCOREEXT48316	Extreme White Foam Board®	4' x 8' x 3/16"

ENCORE MightyCore® - Medium Rigidity

Features & Benefits

- Medium rigidity
- Heavy duty paper surface available in white or black
- Digital, paint & silk screen receptive
- Rigid polystyrene core

Applications

- Digital imaging • Exhibits • Framing • Litho mounting • Painting • Air brushing
- POP displays • Screen printing • Vinyl lettering • Models • Signs

Fabrication

- Machine cutting • Die cutting • Hand cutting

SKU	DESCRIPTION	SIZE
MIGHTYBK4812	Black Mighty Foam Board	4' x 8' x 1/2"
MIGHTYBK4814	Black Mighty Foam Board	4' x 8' x 1/4"
MIGHTYWT4812	White Mighty Foam Board	4' x 8' x 1/2"
MIGHTYWT4814	White Mighty Foam Board	4' x 8' x 1/4"

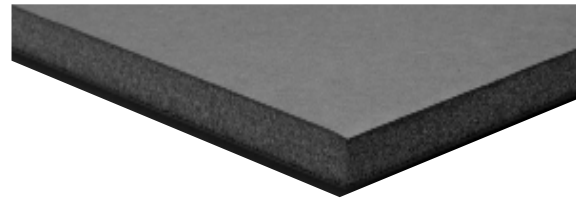

ENCORE DuraPrime - Highest Rigidity

Features & Benefits

- Highest rigidity & the most durable of ALL Encore sheeting
- 0.015 polystyrene surface available in white or black
- Vinyl, digital, paint & silk screen receptive
- Rigid polystyrene core-dent and wrap resistant

Applications

- Digital imaging • Exhibits • Laminating • Litho mounting • Painting • Signs
- Air brushing • POP displays • Models • Vinyl lettering • Screen printing

Fabrication

- Machine cutting • Die cutting • Embossing • Hand cutting • Scoring

SKU	DESCRIPTION	SIZE
DURABK4812	Black DuraPrime Foam Board	4' x 8' x 1/2"
DURABK48316	Black DuraPrime Foam Board	4' x 8' x 3/16"
DURAWT4812	White DuraPrime Foam Board	4' x 8' x 1/2"
DURAWT48316	White DuraPrime Foam Board	4' x 8' x 3/16"



Cooley-Brite® LITE 8 Year Warranty

Cooley-Brite Lite is based on the same proven technology as Cooley-Brite. Cooley-Brite Lite is lighter in weight, 16 oz., offering unique flexibility for ease of installation. As with Cooley-Brite it is translucent, flexible, durable and is engineered for high color brilliance and consistent color transparency.

Available Rolls Sizes: 6'6" x 10yds, 6'6" x 25yds & 6'6" x 50yds
Custom Cut to Size Lengths Available

SKU	COLOR
CBL0606	White
CBL1	Cherry Red
CBL10	Black
CBL11	Plum Purple
CBL13	Teal

SKU	COLOR
CBL15	Petro Green
CBL16	Intense Blue
CBL17	Tangerine
CBL18	Ruby Red
CBL19	Raspberry

SKU	COLOR
CBL2	Bright Red
CBL20	Sunflower
CBL21	Holly Green
CBL22	Burgundy
CBL4	Lemon Yellow
CBL5	Navy Blue
CBL6	Royal Blue
CBL7	Emerald Green

Cooley-Brite® 8 Year Warranty

Cooley's original backlit sign and awning material. This 20oz. membrane features a scrim design that is nearly invisible to allow for maximum light diffusion, consistent translucency and brilliant eradicable colors in backlit signs and awnings. Cooley-Brite is treated with anti-wick, ultraviolet stabilizers, fungicides & whiteners for excellent color protection, durability & long life.

Available Rolls Sizes: 6'6" x 10yds, 6'6" x 25yds & 6'6" x 50yds
Custom Cut to Size Lengths Available

COOLEY BRITE	COOLEY BRITE II	COLOR
83-0123	83-C0123	0123 Sunflower
83-0132	83-C0132	0132 Bright Red
83-0219	83-C0219	0219 Pink
83-0248	83-C0248	0248 Plum
83-0301	83-C0301	0301 Mid Blue
83-0355	83-C0355	0355 Light Green
83-0606	83-C0606	0606 White
83-2020	83-C2020	2020 Burgundy
83-2025	83-C2025	2025 Black
83-2037	83-C2037	2037 Yellow

Cooley-Brite® II 10 Year Warranty

This 20oz. flexible, eradicable, top-of-the-line sign and awning membrane possesses all the advantages of the colored Cooley-Brite and more. Cooley-Brite II features the added protection of Cooley's Coolthane® formulation, which enhances cleanability and extends the life of the product to ten years.

Available Rolls Sizes: 6'6" x 10yds, 6'6" x 25yds & 6'6" x 50yds
Custom Cut to Size Lengths Available

COOLEY BRITE	COOLEY BRITE II	COLOR
83-2108	83-C2108	2108 Green
83-2114	83-C2114	2114 Dark Blue
83-2119	83-C2119	2119 Orange
83-2146	83-C2146	2146 Ivory
83-2283	83-C2283	2283 Dark Red
83-2648	83-C2648	2648 Light Blue
83-2662	83-C2662	2662 Light Red
83-4048	83-C4048	4048 Forest Green
83-5019	83-C5019	5019 Teal
83-5025	83-C5025	5025 Reflex Blue



DPF 390 19.5 oz • 1 Year • Heavy Weight White Media - Durable Flex

Opacity: >75%

Eco-Solvent - Solvent - Latex - UV

DPF 390 is a high-quality, intermediate backlit 19.5-oz white flexible substrate. It is designed for any backlit illuminated indoor or outdoor signage. The heavy weight, durable flexible substrate is both tear and curl resistant, and it is RF weldable. It is compatible with various tensioning systems. DPF 390 has an anti-fungus & anti-wicking treatment.

Recommended Use:

- Back Illuminated Signs
- Awnings
- LED or Fluorescent Light Boxes

SKU	SIZE	COLOR
DPF390-4'-164	4'6" x 164'	White Gloss
DPF390-6'-164	6'6" x 164'	White Gloss
DPF390-8'-164	8'6" x 164'	White Gloss
DPF390-12'-164	12'6" x 164'	White Gloss

Custom Cut Yardage Available



Aluminum Sheeting

Pre-painted aluminum sheets have baked enamel finished in a variety of sizes and colors. All painted aluminum sheets are 3105 alloy and are film masked on one side for protection.

Availability Chart

	3x8 040 mask	4x8 024 mask	4x8 032 mask	4x8 040 mask	4x8 040 soft	4x8 063 mask	4x8 063 hard	4x8 080 mask	4x8 080 hard	4x8 090 hard	4x8 125 hard	4x10 040 mask	4x10 063 mask	4x10 080 mask	4x12 040 mask	5x8 040 mask	5x8 063 mask	5x10 040 mask	
Black (Gloss)				✓								✓							
Black (Matte)				✓								✓							
Blue (Heron)				✓															
Blue (Pepsi)				✓															
Blue (Chevron)				✓															
Bronze (Dark)			✓	✓		✓						✓	✓						
Brown Autumn				✓															
Burgundy				✓															
Clr. Bright Mirror				✓															
Clr. Brush Bright				✓															
Clr. Satin Anodized				✓															
Mill 3003					✓														
Mill 5052							✓		✓	✓	✓								
Green (Ivy)				✓								✓							
Ivory				✓															
Red (Hunter)				✓								✓							
White	✓	✓	✓	✓		✓		✓				✓	✓	✓	✓	✓	✓	✓	✓
Yellow				✓															

White Aluminum Blanks

Pre-painted white aluminum sheets have baked enamel finish & are cut precisely to sizes indicated below. Blanks are film masked on one side for protection.

Availability Chart

	Thickness - 040		Thickness - 063		Thickness - 080	
	radius corner	square corner	radius corner	square corner	radius corner	square corner
6x12		✓				
6x24		✓			✓	
6x28		✓				
6x36		✓				
12x18		✓	✓		✓	✓
18x24	✓	✓	✓		✓	✓
20x28		✓				
24x24		✓	✓		✓	✓
24x36		✓	✓		✓	✓
36x48		✓			✓	
48x48		✓				

See next page for Reflective and Blanks with holes

White Reflective Blanks With Holes

	Thickness - O80 radius corner
12" x 18"	✓
18" x 24"	✓

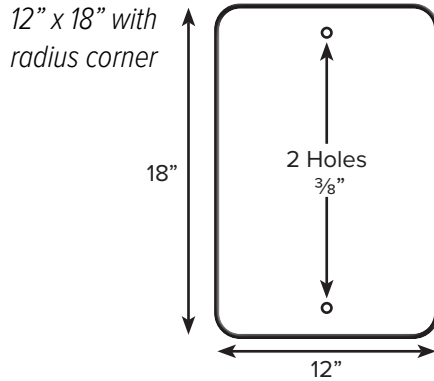

White Aluminum Blanks With Holes

	Thickness - O80 radius corner
12" x 18"	✓
18" x 24"	✓

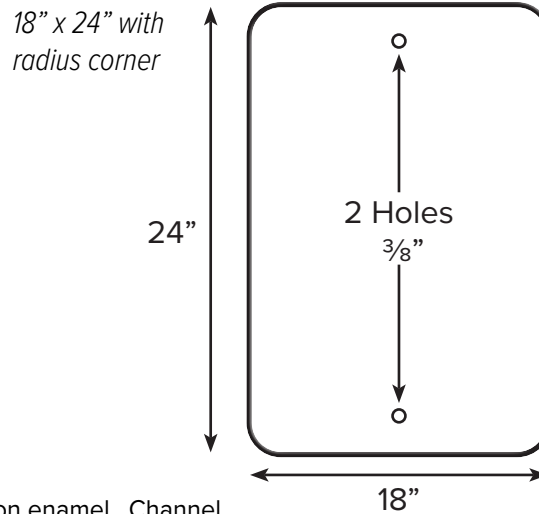

Aluminum Channel Letter Coil

A pre-slit continuous coil of aluminum sheet with baked on enamel. Channel letter coil is used as the sidewall of illuminated channel letters. Much lighter and easier to install than steel - aluminum channel letter coil does not rust either.

SKU	DESCRIPTION	SIZE
270/040/3.5BKGS	Gloss Black	3.5" x 270' x 040
270/040/3.5WTGS	Gloss White	3.5" x 270' x 040
270/040/3.5BKMT	Matte Black	3.5" x 270' x 040
270/040/4.3WTGS	Gloss White	4.3" x 270' x 040
270/040/4.5BRZ	Bronze	4.5" x 270' x 040

SKU	DESCRIPTION	SIZE
270/040/5.3BKGS	Gloss Black	5.3" x 270' x 040
270/040/5.3WTGS	Gloss White	5.3" x 270' x 040
270/040/5.3RED	Hunter Red	5.3" x 270' x 040
270/040/5.3BKMT	Matte Black	5.3" x 270' x 040
270/040/5.3BRZ	Bronze	5.3" x 270' x 040



SKU	DESCRIPTION	SIZE
270/063/2MILL	2" Mill Finish	2" x 270' x 063
270/063/3MILL	3" Mill Finish	3" x 270' x 063

Showcard

The industry standard for rigid laminated SBS display board. It is often used for retail signage and displays. Offering superior flatness, high rigidity and excellent printing and converting properties. Consistent quality and solid bright white appearance on both sides makes it an excellent choice for high quality applications. The super smooth clay coating can be directly screen, offset or digitally printed. The solid white core makes it an ideal choice for digital printing, die cutting or photo mounting.

SKU	DESCRIPTION	SIZE
S/F-RAINCOTE	1-Sided, White Showcard 6-ply	.024 - 28 x 44
D/F-RAINCOTE	2-Sided, White Showcard 14-ply	.044 - 28 x 44



Blue Economy Squeegee

Our lowest cost squeegee is made from a long-lasting polyblend — not too stiff and not too soft. The perfect squeegee to supply with customer installed vinyl. Replace your squeegees often for bubble free applications!

SKU	SIZE
SQUEEGEE/BLUE	2 ¾" x 4"



6" Plastic Squeegee with Felt

Standard-weight felt edge wrapped squeegees. Helps protect vinyl from marring and scratching. Saves time and money by eliminating the need to "wrap" a squeegee, or using a pre-mask.

SKU	SIZE
SQFLT6	3" x 6"

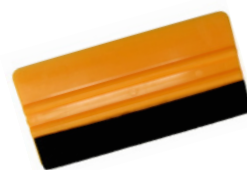

3M Gold Squeegee

The Professional's Choice. The 3M Gold Squeegee is a stiff vinyl/nylon construction with a reinforced edge for a bubble-free application. Lasts the longest!

SKU	SIZE
SQUEEGEE/GLD	2 ¾" x 4"



12" Plastic Squeegee

Ideal for vinyl, film, graphics, tape, silk screen, and pressure-sensitive applications. Featuring high-stability ribbed profile with radial corners in a poly-flow blend. Twin ribs for easy handling and pressure control. With a true edge, strong memory, medium flex and high glide. Rounded corners based on industry standards.

SKU	SIZE
SQ12	2 7/8" x 12"

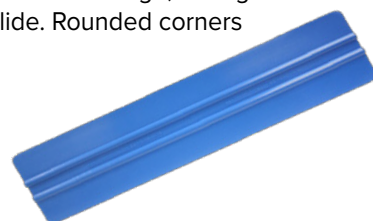

Felt Squeegee (Rectangular)

Our solid felt rectangular squeegees are a must for working with digital prints and vehicle wrap applications. Manufactured from a soft yet firm felt.

SKU	SIZE
SQUEEGEE/FELT	2 ¾" x 4"



Squeegee Sharpener

The squeegee sharpening tool smooths the rough edges and nicks that your hard cards develop over time. The squeegee sharpening tool will help your hard cards last longer. With one or two strokes your squeegee edge is restored to the same condition as when it was first used.

SKU	SIZE
SQSHARP	1 3/8" x 3 1/8"



White Oracal Teflon Squeegee

Stiff Edge with a Slick Surface. The Oracal Teflon squeegee features a rigid Teflon construction with a very hard edge. Best for flat surfaces.

SKU	SIZE
SQUEEGEE/WHT	2 ¾" x 4"



Lil Chizler Vinyl Remover - Almond

One sized polycarbonate tool has proven invaluable for removing materials and applying others in tight corners. Millions used by Vinyl & Film professionals. Custom rolled edges scrapes without marring.

SKU	SIZE
LIL CHIZLER	2" x 1"



Yellow Oracal Felt Edge Squeegee

The Oracal Felt-edge Squeegee is the best choice for sign shops working with a mix of printed and vinyl. Manufactured from rigid plastic with one edge covered with a durable felt to help prevent scratching when applying digital prints.

SKU	SIZE
SQUEEGEE/YEL	2 ¾" x 4"



Siser Squeegee

Smooth out your masking films and remove unwanted air bubbles with this handy plastic tool. Recommended for use with all Siser printable digital materials. The Siser squeegee removes trapped air and creates a bond between the mask and the image.

SKU	SIZE
SISQUEEGEE	2 ¾" x 4"



Xtreme Cutting Mat

Simply The Best Counter Top Cutting Mat! Protects your table top. The cutting blades last longer. Made from virgin high impact polymer blend.

SKU	SIZE
CM48	4' x 8' x 3/16"
CM412	4' x 12' x 3/16"
CM512	5' x 12' x 3/16"

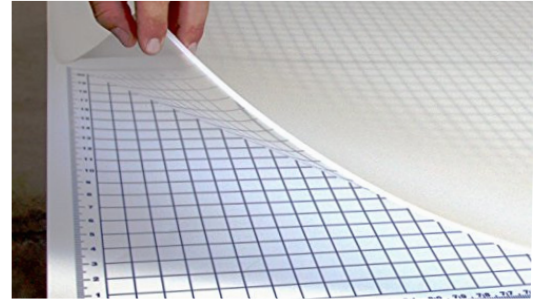

Big Blue Safety Ruler

The number one choice for the finishing room. More features & benefits than any other safety ruler! Made of heavy duty aluminum construction. Polished and anodized. Non-slip grip on the bottom. Excellent curved finger guard. Laser etched graphics and measurements. Channel on back to hold cutting head so all sizes make perfectly straight cuts the entire length.

SKU	SIZE
ECSL28	28"
ECSL52	52"
ECSL76	76"

Use with Foamboard Straight Cutter!



Foamboard Straight Cutter

Cut perfect straight edges on any depth of foamboard from 1/8" to 1/2". Adjustable blade depth.

SKU	CUT DEPTH
WC6001	1/8" - 1/2"



Don't Forget!
Replacement Blades
(20 Pack) SKU: WC20
see page 97

Orange Xtreme Magnets

A must for every shop and installer. Make applying vinyl and wraps easy. Large 1 5/8" diameter super soft rubber coating will NOT harm your graphics or substrates. Bright neon color make them easy to locate. Use in place of masking tape to position graphics.

SKU	QTY
XMH6	6 pack



4 3/4" Sharp Pointed Tweezers

ProEdge 4-3/4 inch Stainless Steel Sharp Pointed Tweezer is featured with tapered shanks for precise holding, control and inspecting small objects.

SKU	SIZE
53360	4 3/4"



Complete Weeding Kit

Strong stainless steel tips and chrome handles. Five different angles for picking and weeding anything. Cast, calendered, heat transfer & more...

SKU	PIECES
CWK	5 Tools in Kit



Rivet Brush - Vinyl Application - 1.5"

Wooden handle rivet brush with nylon bristles. For vinyl application around rivets and other difficult to conform surfaces.

SKU	SIZE
RBX1	1" Brush - 1 1/2" handle



GRAPHIC TOOLS

KNIVES & BLADES

OLFA 180 Standard Duty Cutter

Features a slide lock, pocket clip and Built in Blade snapper

SKU

180



OLFA Auto Lock Stainless Steel Professional Knife

For RH & LH users with auto-lock blade, pocket clip and blade snapper.

SKU

SVR2

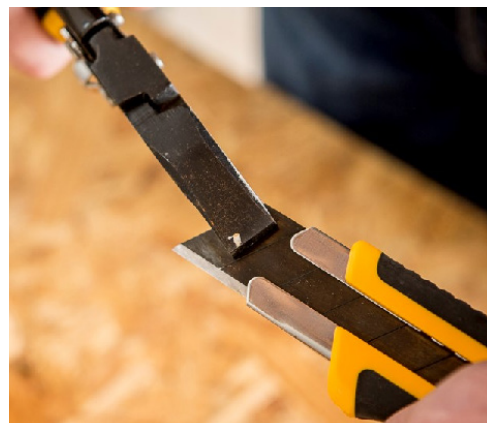

OLFA Carbon Steel Snap Off Replacement Blades

Get a blade that lasts six times longer; offers faster change-out; is safer; and is always sharp, fresh and ready to go, enhancing productivity.

SKU	QTY
ABB10B	10 Pack
ABB50B	50 Pack



When You're Ready to "Snap" the Blade

When using a pair of pliers, advance the blade out so the perforation is past the back support wall located on the back of the knife. The support wall exists so the blade doesn't break mid-cut, but to snap, the blade must go past it. Use the pliers to grasp the blade firmly and snap along the perforation.

Craft Knife - Natural Silver or Prosure Grip

Compare to X-Acto knives. Takes #11 blades. Comes with (1) blade and protective cover.

SKU	COLOR
12010	Silver
12040	Red
12041	Blue
12042	Green
12043	Purple
12044	Black



You May Also Need...

Long lasting #11 blades for use in standard X-Acto or ProSure knives. Box of 100. SKU: 11-100



Replacement Razor Blades

The Proedge 5700-9 is a pack of replacement utility knife blades. For cutting, scraping paint and sticker removal on windows and glass. Blade type: Single edge utility blade. Size: 1 1/2" (back) x 3/4" x 1 1/2" (cutting edge). Blade thickness: .009"

SKU	QTY
5700-9	100

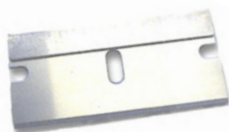

EZ Gripper Wide Media and Vinyl Handling Tool

The E.Z. Gripper Wide Media Installation Tool™ maintains even tension of the media to reduce potential creases and avoid accidental folding and flopping of media edges. It handles wide materials on both horizontal and vertical installations and applies and controls media with or without pre-masking. One-person control on wider pieces of vinyl. Prevents ends and edges from folding or flopping. Evens tension on media and lessens potential creases. Applies & controls media with or without pre-masking.

SKU	SIZE
EZ-GRIPPER-30	30"
EZ-GRIPPER-54	54"



4 Inch Speedball Roller Applicator

The roller applicator allows firm 90 degree downward pressure when applying pressure sensitive adhesive materials, without scratching the surface, no matter what angle the user holds the handle.

SKU	SIZE
SBX1	4"



Pro-Roll Tape Applicator

Each size works with widths up to that size tool. No more wrinkles when applying. Change to a new roll in seconds. Works with any brand, paper weight and tack level of application tape.

SKU	SIZE
TA12	Tapes from 3" to 12"
TA24	Tapes from 3" to 24"



Tack Roller & Cleaning Sheets

Removes every spec of unwanted dust and other particles from surfaces before printing, laminating or applying graphics. Available in 2 tack levels- Medium & High. Kit includes: 1- Tack Roller and 1 box of 50 cleaning sheets.

SKU	SIZE
DR12AMT	12" Medium Tack Roller
DR12AHT	12" High Tack Roller
CP50	1 box (50 Cleaning Sheets)



Pro-Tabletop Applicator

Mount to your existing work table. Adjust to your desired width. Secure brackets to your table top. We suggest 1" aluminum tubing. Tubing NOT included. Works with most roll goods vinyl – transfer tape – etc.

Kit includes: 2 – Mounting Brackets (1 left hand – 1 right hand)
 6 – 1" Quick Release Clamps
 6 – 1" End Caps
 6 – 3" Core Plugs

SKU	SIZE
PTA1000	Adjustable



Mondo Raxx Jumbo Wall Media Storage

The Jumbo Mondo RAXX is a ten-roll capacity large format media rack that holds 50 yard rolls of vinyl, print media, paint replacement film, banner media and more. Jumbo Mondo RAXX are made from heavy-duty stamped aluminum.

*****Only vertical racks included. Desired poles purchased separately*****

SKU	SIZE
MJ1000	Adjustable



Heavy Duty Mobile Floor Rack - 3" Core

Holds 3 inch core rolls of media, vinyl, inkjet film, paper, banner material, etc. The oversized wheels on this rack enable it to move easily even when loaded up with heavy material. Accommodates larger core size rolls and holds 25% more than 12 slot rack. Holds 1000 lbs. Dimensions: 17" High x 24" Wide x 25" Deep

SKU	SIZE
MR16	17" x 24" x 25"

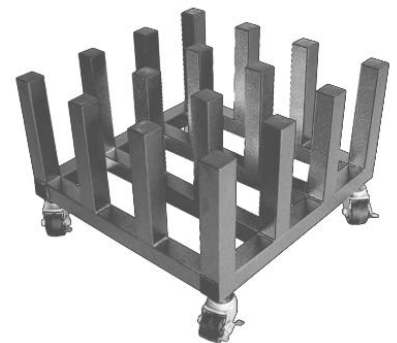

Chrome Plated Wall Mount Material Rack

Heavy gauge wire constructed rack holds sixteen (16) rolls of 3" core diameter material without using valuable floor space. This rack is durable enough to hold even up to 16 rolls of 30" x 50 yds material with ease. Proper storage of pressure sensitive materials dictate supporting rolls by the core to avoid adhesive activation. Included are adjustable screw mounting clips, allowing alignment with studs in most walls. Holds up to 30" x 50 yds material.

SKU	SIZE
WR-1600	22" x 28"



Helpful Tip!

Extreme pressure on any surface of a roll will result in surface marring (Mottling). This is usually caused by stacking multiple rolls on top of one another for a long period of time.

One storage tip is to keep rolls stored vertically instead of horizontally.

Grafix Gone Adhesive Remover - Quart

GRAFIX GONE® softens adhesive residue for removal within 90 seconds on most surfaces. Spot test on new paint before using. It will not burn most plastics and will not harm latex paint. No extra cleanup after removing adhesive residue. Smells good, works great & safe to ship.

Great for removing old paper sheeting from plastics.

Use on:

Vinyl Banners • Plexiglas™ • Styrofoam™ • Lexan™ • Styrene • Glass • Painted Surfaces

SKU	SIZE
GRAF/GONE-QT	Quart



SPLASH Vinyl Application Fluid - 8 oz.

Vinyl application fluids are designed to make the application of pressure sensitive vinyls and decals quick and easy by allowing you time to position your graphics and remove air bubbles prior to adhesion. The application fluid wets the surface, allowing you to slide the graphics until you get the exact placement. No need to worry about the adhesive sticking before you are ready. Supplied in 8 oz. plastic bottles which dilute to make one gallon of vinyl application solution.

SKU	SIZE
SPLASH	8 oz.



Action Tac Vinyl Application Fluid - Quart or Gallon

Ready-to-use application fluid for all grades of vinyl. Less aggressive and more efficient than other products resulting in stable, fast vinyl transfers. It's also an excellent cleaner and prep agent. It will not attack transfer tape or cause separation. Available in gallons or quarts.

SKU	SIZE
ACTION/GAL	Gallon
ACTION/QT	Quart



Window Juice Application Fluid for Glass - Quart

Window Juice gives you time to position your graphics and gets you off the job fast! No more long waits to remove transfer tape. Do it now, do it quick, and do it right with Window Juice. Use with pressure sensitive vinyls and decals. Fast, simple, clean application. Allows time to position your graphics. Eliminates bubbles and wrinkles. Remove your transfer tape in under two minutes. Works in extreme weather conditions cold or hot, dry or warm.

SKU	SIZE
WINDOW/QT	Quart



3M Woodgrain & Stripe Removal Vinyl Film & Stripe Remover

Easy removal of vinyl films and stripes saves time and minimizes extra repairs. Sprays quickly and easily from an aerosol can — no mixing or mess. Won't damage paint or clear coat, reducing buffing or repainting. Gel solution resists running or dripping, reducing cleanup on vertical surfaces

SKU	SIZE
08907	18 oz. Can



Avery Paper Bond Perforated #20

The Avery paper bond is a superior quality ink and paint receptive paper used for poster, window displays and temporary signage of all types. The paper is sized for maximum media versatility & color impact. This paper bond is perforated & is not coated.

SKU	SIZE
Z1043S	15" x 500'
Z1044S	30" x 300'

Tara Bond Paper 20lb

A superior quality ink and paint receptive paper used extensively for poster, window displays and temporary signage of all types. The paper is sized for maximum media versatility and color impact.

SKU	SIZE
2513	24" x 50yd - 20lb
2514	36" x 50yd - 20lb
2515	48" x 50yd - 20lb
2517	24" x 300yd - 20lb
2518	36" x 300yd - 20lb
2519	48" x 300yd - 20lb



Stabilo Marking Pencil

A water-soluble pencil that will mark clearly, densely and legibly on **any surface** including acetate, paper, glass, metal, photo and film. Wipes off with a damp cloth on smooth surfaces and erases on paper.

SKU	COLOR
8046	Black
8041	Blue
8008	Graphite
8040	Red
8052	White



Vinyl Clip

Keeps vinyl and print media properly wound. No more using tape damaging your vinyl. 2 Sizes for both 10 and 50 yard rolls. Doesn't scratch or leave marks on your delicate rolls.

SKU	QTY
SC-12	12 pack
SC-50	50 pack



Cotton Gloves

Keep sensitive products clean from fingerprints and smudges. Form fitting for easy movement. Use for product inspection or light manufacturing. 100% cotton.

SKU	QTY
S-7892	12 pairs



Hook and Loop Fasteners

Nylon Velcro General Purpose hook and loop fasteners have an acrylic adhesive and are suitable for a wide range of applications thanks to the versatility and durability of synthetic nylon yarns.

*Hook and loop sold in separate rolls or together as a **KIT***

SKU	MATERIAL	HOOK / LOOP	BACKING	COLOR	SIZE
190911	Velcro Nylon	Loop 1000	Acrylic Adhesive	Black	¾" x 25yd
190899	Velcro Nylon	Loop 1000	Acrylic Adhesive	White	¾" x 25yd
190935	Velcro Nylon	Hook 88	Acrylic Adhesive	White	¾" x 25yd
190940	Velcro Nylon	Hook 88	Acrylic Adhesive	Black	¾" x 25yd
90082	Velcro Nylon	Hook/Loop KIT	Acrylic Adhesive	White	¾" x 5yd

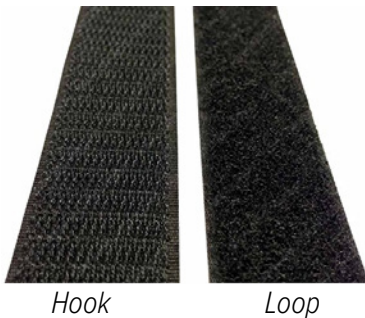

**Hook & Loop KIT
Available
SKU: 90082**

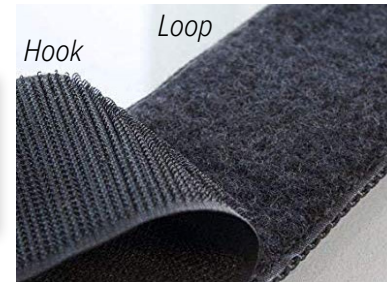

Polyester These Sew-On or Acrylic Adhesive Velcro Marine Grade hook and loop fasteners are UV, chemical, and water resistant, making them ideal for applications where outdoor durability is a must.

Hook and loop sold in separate rolls.

SKU	MATERIAL	HOOK / LOOP	BACKING	COLOR	SIZE
155334-ADH	Velcro Polyester	Hook 81	Acrylic Adhesive	Black	1" x 25yd
155474-ADH	Velcro Polyester	Hook 81	Acrylic Adhesive	Black	2" x 25yd
155533-ADH	Velcro Polyester	Hook 81	Acrylic Adhesive	White	1" x 25yd
155475-ADH	Velcro Polyester	Hook 81	Acrylic Adhesive	White	2" x 25yd
190582-SEW	Velcro Polyester	Hook 81	Sew On	Black	1" x 25yd
190789-SEW	Velcro Polyester	Hook 81	Sew-On	Black	2" x 25yd
190579-SEW	Velcro Polyester	Hook 81	Sew-On	White	1" x 25yd
190787-SEW	Velcro Polyester	Hook 81	Sew-On	White	2" x 25yd
155237-ADH	Velcro Polyester	Loop 9000	Acrylic Adhesive	Black	1" x 25yd
155476-ADH	Velcro Polyester	Loop 9000	Acrylic Adhesive	Black	2" x 25yd
155238-ADH	Velcro Polyester	Loop 9000	Acrylic Adhesive	White	1" x 25yd
155412-ADH	Velcro Polyester	Loop 9000	Acrylic Adhesive	White	2" x 25yd
190468-SEW	Velcro Polyester	Loop 9000	Sew-On	Black	1" x 25yd
190713-SEW	Velcro Polyester	Loop 9000	Sew-On	Black	2" x 25yd
190465-SEW	Velcro Polyester	Loop 9000	Sew-On	White	1" x 25yd
190711-SEW	Velcro Polyester	Loop 9000	Sew-On	White	2" x 25yd

3M 4949 VHB Double Face Tape

45 mil thick - Black

3M™ Black VHB™ Tape 4949 is a firm double sided, pressure sensitive, closed cell acrylic foam tape with a paper liner.



SKU	SIZE
4949-3/4	¾" x 36 YD

3M 4905 VHB Double Face Tape

20 mil thick - Clear

3M™ Clear VHB™ Tape 4905 is a clear double-sided, pressure-sensitive, acrylic tape with PE film liner.



SKU	SIZE
CLR-4905-3/4	¾" x 72 YD

3M 4622 VHB Double Face Tape

45 mil thick - White

Double-sided, double coated conformable acrylic foam, general purpose acrylic adhesive face side, multi-purpose acrylic adhesive liner side, closed cell, white.

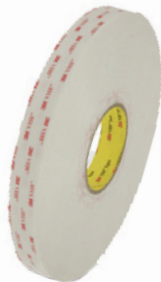

SKU	SIZE
4622-1/2	½" x 72 YD
4622-7/8	⅞" x 36 YD

3M 4950 VHB Double Face Tape

45 mil thick - White

3M™ VHB™ Tape 4950 is a firm, double-sided, pressure-sensitive, closed-cell acrylic foam tape with a paper liner. Bonds high surface energy substrates. Provides handling convenience, cushioning, damping, and impact resistance.



SKU	SIZE
4950-1/2	½" x 36 YD
4950-3/4	¾" x 36 YD

Oracal 3601 UHB Double Face Tape

43 mil thick - White

Ideally suited for structural general bonding of aluminum, various plastic sign, display substrates and window glazing bars.



SKU	SIZE
3601-1/2	½" x 36 YD
3601-3/4	¾" x 36 YD
3601-1	1" x 36 YD

Oracal 3597 UHB Double Face Tape

43 mil thick - Clear

Ideally suited for adhering clear on transparent plastics and general bonding of aluminum, body panels; emblems and illuminated signs/displays.

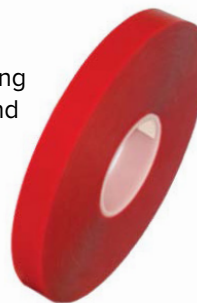

SKU	SIZE
3597-1/2	½" x 36 YD
3597-3/4	¾" x 36 YD
3597-1	1" x 36 YD

Polyethylene Double Face Foam Tape

White

Double-coated, double-sided polyethylene acrylic foam tape. Great economical choice for general foam tape requirements.

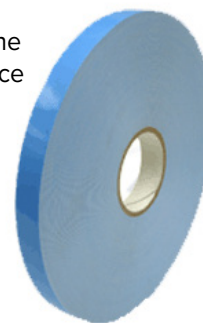

SKU	SIZE
5000190	½" x ¼" x 36 YD
5000193	¾" x ¼" x 36 YD
5000196	1" x ¼" x 36 YD
5000216	1" x ½" x 72 YD

Helpful Tip!

3M VHB & Oracal UHB Tapes typically reach **full bond** after 72 hours, **50%** after 20 minutes, and **90%** after 24

Double Face Seam Tape

4 mil thick

This tape is a high-performance, clear, double coated polyester tape with excellent resistance to high temperatures. This tape is coated with an extremely aggressive adhesive. It is used for holding in place a wide variety of rigid and flexible features. Its best uses are with **fabrics and zipper seams**.

Features:

Polyester film is easy to handle and adds strength and dimensional stability. Laminates well to a variety of substrates, acrylic, PVC, polyester and coated fabrics. Excellent balance of properties makes this product useful in a multitude of applications. Performs well over a wide temperature range.



SKU	SIZE
6696-1/4	1/4" x 60 YD
6696-1/2	1/2" x 60 YD
6696-3/4	3/4" x 60 YD

3M 200 Tape

General Purpose Masking Tape

3M™ Paper Tape 200 is a utility purpose paper tape for holding, bundling, sealing, non-critical masking tape and a vast number of other jobs where a pressure-sensitive tape is needed.

Benefits and Features:

Heavy thickness crepe paper backing for good paint lines. Natural rubber adhesive for good instant adhesion. Easy tear, pressure sensitive. Transportation, aerospace, automotive, commercial vehicle, RV, bus, truck, ship yards, military, metal working, furniture, electronics, solar, trailer manufacturing and woodworking. Sealing, holding, bundling, reinforcing, identifying, tabbing, wrapping, paint masking, splicing and protecting.



SKU	SIZE
3M-3/4	3/4" x 60 YD
3M-1	1" x 60 YD
3M-2	2" x 60 YD

Tuff Tape III™ Double Face Banner Tape

43 mil thick - Clear

Ideal for making "instant" banner hems. This transparent, heavy duty, double sided tape is resistant to water, moisture and temperature fluctuations. The acrylic adhesive is UV and plasticizer resistant with an excellent bond to most vinyl fabrics. This tape offers high adhesion to ensure a permanent bond to aluminum, wood, brass and plastics for signage or plaques.



SKU	SIZE
1/2-CT468	1/2" x 36 YD
1-CT468	1" x 36 YD

Filament Reinforced Packaging Tape

7 mil thick

On a 3 inch paper core, this tape is a 7 mil glass filament-reinforced polyester film backing with high-shear strength acrylic adhesive.



SKU	SIZE
3M-8934	3/4" x 60 YD

PowerTape™ Hem Reinforcing Banner Tape

Single-sided tape with super strong film. No need to fold the hem so there is no risk of unfolding. Primarily for use with outdoor banners. Will reduce edge curl on vertical indoor banners. Recommended for banners in excess of 8' or where maximum wind resistance is needed.

SKU	SIZE
PTAPEB	1 1/2" x 36 YD

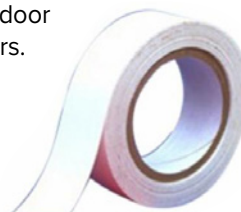

Did You Know?
Storing your tapes in a controlled temperature between 50°F - 75°F will ensure you get the maximum life out of your tapes. Extreme cold or heat will prematurely reduce the tackiness



Application Tape 4075 Conform RLA

Premium High Tack Application Tape with Release Liner Adhesion

Standard weight saturated paper with high tack natural latex adhesive for clean pick up and transfer of small and medium size lettering and graphics. User friendly easy unwind and clean tearing features. Sticks and lays flat to the exposed release liner around cut vinyl graphics to protect against wrinkling, tunneling and edge curling.



SKU	SIZE	SKU	SIZE	SKU	SIZE
1-4075-RLA	1 ¼" x 100YD	10-4075-RLA	10 ½" x 100YD	20-4075-RLA	20" x 100YD
2-4075-RLA	2 ¼" x 100YD	12-4075-RLA	12" x 100YD	24-4075-RLA	24" x 100YD
3-4075-RLA	3 ¼" x 100YD	14-4075-RLA	14" x 100YD	30-4075-RLA	30" x 100YD
4-4075-RLA	4 ¼" x 100YD	15-4075-RLA	15" x 100YD	36-4075-RLA	36" x 100YD
6-4075-RLA	6 ½" x 100YD	16-4075-RLA	16" x 100YD	48-4075-RLA	48" x 100YD
8-4075-RLA	8 ½" x 100YD	18-4075-RLA	18" x 100YD	54-4075-RLA	54" x 100YD

ValueTape Standard Grade

Standard Weight Saturated Paper with High Tack Natural Latex Adhesive

Easy unwind, smooth lamination by hand or machine. Pre-mask for small, medium and large vinyl graphics. Releases, tears, and cuts cleanly and easily with no build up of tack level over time.

Long term storage with no surface defects.

SKU	SIZE	SKU	SIZE	SKU	SIZE
1-VALUE	1 ¼" x 100YD	8-VALUE	8 ½" x 100YD	16-VALUE	16" x 100YD
2-VALUE	2 ¼" x 100YD	10-VALUE	10 ½" x 100YD	18-VALUE	18" x 100YD
3-VALUE	3 ¼" x 100YD	12-VALUE	12" x 100YD	20-VALUE	20" x 100YD
4-VALUE	4 ¼" x 100YD	14-VALUE	14" x 100YD	24-VALUE	24" x 100YD
6-VALUE	6 ½" x 100YD	15-VALUE	15" x 100YD	30-VALUE	30" x 100YD
				48-VALUE	48" x 100YD

AT-60N Premium Clear Application Tape

Low Tack for Large or Digital Graphics 24" AND UP

Clear Choice® AT60N is an ultra-clear, low tack film application tape designed to transfer large format graphics. Excellent facestock clarity helps installers precisely align multiple graphic overlays and the rigid polypropylene face material prevents stretching even when applying graphics in hot weather. With it's forgiving adhesive system, AT-60N makes handling and applying large graphics less challenging.

SKU	SIZE
AT-60-24	24" x 100YD
AT-60-30	30" x 100YD
AT-60-36	36" x 100YD
AT-60-48	48" x 100YD

AT-65 Premium Clear Application Tape

High Tack for Small Graphics 24" AND UNDER

Clear Choice® AT65 is an ultra-clear, high tack film application tape that provides exceptional performance and versatility for the widest range of sign applications. AT65 is the tape you will want to keep on hand. It's high tack adhesive system is especially well suited for transferring small, high detail cut graphics and intermediate calendared vinyl films with tight liner release. AT65's exceptionally clear film facestock allows for precise registration of multiple color overlays, while the rigid polypropylene film minimizes stretching for precise alignment of graphics.

Buy any combination of rolls to equal 48" or more and receive additional discounts!

SKU	SIZE	SKU	SIZE	SKU	SIZE
AT-65-2	2 ¼" x 100YD	AT-65-12	12" x 100YD	AT-65-24	24" x 100YD
AT-65-4	4 ¼" x 100YD	AT-65-14	14" x 100YD	AT-65-30	30" x 100YD
AT-65-6	6 ½" x 100YD	AT-65-15	15" x 100YD	AT-65-36	36" x 100YD
AT-65-8	8 ½" x 100YD	AT-65-16	16" x 100YD	AT-65-48	48" x 100YD
AT-65-10	10 ½" x 100YD				

Chromatic Metal and Wood Primer White

Metal and Wood Primer White is a fast drying high opacity primer with good adhesive qualities on both wood and steel. A coarser pigment particle offers the system greater “tooth” than PBOW Block Out White and PMPW Masonite Primer White. Metal and wood primer sands easily. It is also good for use as a primer-burnishing sealer under gold sizes and may be slightly tinted.

SKU	SIZE
PMWPW-GAL	Gallon



Chromatic Block-Out White Primer

Block Out White (PBOW) is a fast drying, high opacity coating that is used to “block out” previous painted sign faces and cover uneven colors of substrates. It is also used to prime new MDO surfaces and is readily sanded. Because of its exceptionally fast dry time, this product is most often used in production environments. Popular in high, and rapid production environments due to its fast drying times, generally drying to a dead flat finish in about 2 hours.

SKU	SIZE
PBOW	Gallon



Chromatic White Universal Waterbase Primer

A waterborne high performance acrylic primer that’s suitable for use on metal, wood, HDU, PVC and most masonry applications. Has excellent adhesion qualities. Easy to apply and sand. Can topcoat within 3 hours.

SKU	SIZE
WP1008-GAL	Gallon



Jay Cooke’s Paint Primer All Purpose

Jay Cooke’s All Purpose Sign Primer is the industry leading high build, water-based, universal primer, sealer and stain blocker. It contains fast dry convenience with outstanding adhesion, build and sealing capabilities, and can be used for both interior and exterior applications and can be used with both latex and enamel topcoats. When used as a primer/sealer on new wood, it provides excellent tooth for surface coatings and will not cause excessive grain raising. It is absent of harmful solvents, it is low odor and requires only water clean-up. Jay Cooke’s All Purpose Sign Primer fills the need of both the commercial shop and dimensional sign maker. It is formulated so only one primer is needed for wood, foam, MDO plywood, fiberboard, vinyl or metal.

SKU	SIZE
JC-PRIME-GAL	Gallon
JC-PRIME-QT	Quart



Frog Juice UV Protection & Edge-Sealing

Frog Juice 7000 Sunscreen Clear is a versatile liquid lamination coating that provides UV protection and edge-sealing properties, and is suitable for use over a wide variety of surfaces including gold leaf, vinyl, enamel receptive banners, latex and properly cured solvent paints, digital prints and more. Frog Juice dries very hard over time, yet remains flexible. It will not yellow. Requires no hardener or catalyst. Achieves maximum hardness slowly over 30 days, yet is ready to handle and place outdoors in 30 minutes.

SKU	SIZE
7000/QT	Quart
7000/SPRAY	12 oz Aerosol



Smith's Cream

Smith's Cream is a colorless painting medium that can be added to paint to create a perfect paint-base for **adhering smalts** to sign backgrounds. It will harden in 24 hours when mixed 50/50 with enamels.

SKU	SIZE
SMITHS/QT	Quart

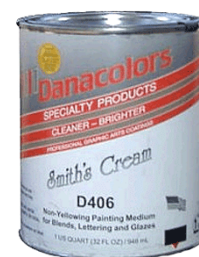

Smalt Glass Black

#0100 Black (Approximate match to 1-Shot Lettering 199 Black). A fine glass used for backgrounds and for special effects. Available in 90% shiny glass finish. An average coverage of 1-½ to 2 square feet per pound. Smalt is the size of coffee grinds. **Use Smith's Cream to adhere to sign backgrounds.**

SKU	SIZE
SMALT-BLK-GLS-5	5lb Container



Gold Size Fast and Slow Set

This size is a clear gilder's varnish designed for fast leaf work. It may also be used as a clear protective top coat over leaf, lettering and other decorative work. Luco Quick Dry Gold Size will be ready for gilding in 1 to 3 hours, depending upon temperature and humidity. The Luco Slow Set Gold Size is a Gilder's Oil designed for all leaf work where extended tack time is allowed, greater brilliance is desired and a clear protective top coat is not necessary. Luco Slow Set Gilder's Oil will be ready for gilding in 10 to 12 hours, depending upon temperature and humidity. This tack will hold up to 24 hours.

SKU	DESCRIPTION	SIZE
L17415-1/2PT	Fast (1-3 Hours)	½ Pint
L19415-1/2PT	Slow (10-12 Hours)	½ Pint



Gold Leaf

Patent Gold Leaf, also referred as Transfer Leaf, is a gold leaf mounted to special tissue paper by a pressure process. This allows the gilder to remove one leaf at a time without disturbing the remaining leaves. The leaf will stay on the tissue until it is pressed onto a prepared surface and the tissue backing is removed. Standard size of each sheet is 3-½" x 3-½". A book will cover approximately 1 ½ Square Feet. A pack/box of 20 books will cover approximately 30 Square Feet.

SKU	SIZE
PAT-L76PT23-BK	3 ½" x 3 ½"



Gold Leaf

Loose Leaves are placed between pages in a book made from specialty tissue paper. The leaves are barely held in place by the paper and will come loose with a light puff of air. Loose Leaf is generally preferred by professional guilders when working indoors the leaf is easily moved and applied using a guilders tip brush. Standard size of each sheet is 3-½" x 3-½". A book will cover approximately 1 ½ Square Feet. A pack/box of 20 books will cover approximately 30 Square Feet.

SKU	SIZE
DEEP-L76D23-BK	3 ½" x 3 ½"

1-Shot Lettering Enamel Paint

Superior oil-based high-gloss enamel paint for interior or exterior use. Approved for use on metal, glass (not for windshields), wood, masonite, MDO and enamel receptive banner and vinyl materials. Excellent for vehicles and anywhere fine lettering work is required. Superior flow characteristics nearly eliminate brush marks provide a clean, sharp edge. May be airbrushed when reduced with 6001 Low Temp Reducer.



Shelf Life: Unopened: 48 Months Opened: 12 months

108-L Maroon	106-L Kool Crimson	104-L Bright Red	165-L Rubine Red	102-L Fire Red	100-L Vermillion	124-L Orange	120-L Coral
117-L Tan	191-L Imitation Gold	109-L Gold Metallic	134-L	132-L Lemon Yellow	130-L Primrose Yellow	141-L	142-L Emerald Green
143-L Process Green	144-L Medium Green	148-L Dark Green	150-L Blue Green	157-L	149-L Aqua	151-L Robin Egg Blue	153-L Process Blue
154-L Blue Peacock	152-L Light Blue	155-L Reflex Blue	156-L Brilliant Blue	158-L Dark Blue	161-L Proper Purple	162-L Purple	164-L Dark Magenta
163-L Magenta	160-L Violet	168-L Salmon Pink	116-L Ivory	118-L Chamois	111-L Brass Metallic	110-L Copper Metallic	115-L Dark Brown
114-L Medium Brown	101-L Lettering White	103-L Polar White	193-L Silver Metallic	195-L Medium Gray	199-L		

**Actual colors may vary slightly from examples shown due to limitations in the printing process.*

Chromatic Bulletin Enamel Paint

High Alkyd-Resin (oil base) gloss finish for signs! Single coat coverage, fast drying. Formulated for excellent durability, and easy application on large areas. Bulletin colors can be brushed, rolled or sprayed-on. Ideal for billboards, exterior signs as well as interior murals.

Shelf Life: Unopened: 48 Months Opened: 12 months



108
Maroon



104
Bright Red



106
Carmine



102
Fire Red

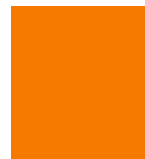

124
Orange



134
Chrome Yellow

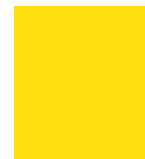

132
Lemon Yellow



130
Primrose Yellow



140
Light Green



142
Emerald Green



144
Medium Green



148
Dark Green



150
Blue Green



153
Process Blue



152
Light Blue



156
Brilliant Blue



158
Dark Blue



166
Reflex Blue



162
Purple



163
Magenta



116
Ivory



115
Dark Brown



114
Medium Brown



101
White



195
Medium Gray



21
Black



21F
Flat Black

**Actual colors may vary slightly from examples shown due to limitations in the printing process.*

Chromatic White Background Enamel

Single component, fast-drying high gloss enamels for sign backgrounds where expedient drying is desired over metal, wood, some plastics and HDU. Usually dry to the touch in 2 hours. Available in OAAA compliant 101 White.

Shelf Life: Unopened: 48 Months Opened: 12 months

SKU	SIZE
BEW-GAL	Gallon



1-Shot Chromaflo 6000 Flow Enhancer

ChromaFlo is designed to act as a flow enhancing additive for use with brush applications of 1 Shot Lettering Enamels and Chromatic Bulletin Colors. Not to be mistaken as a reducer, ChromaFlo - when used sparingly, will increase brush control, decrease brush drag and enhance flow and leveling characteristic; especially suitable for lettering and pin striping applications.

Shelf Life: Unopened: 72 Months Opened: 72 months



SKU	SIZE
6000/QT	Quart

1-Shot Solvent Hardener 4007

1-Shot's Hardener is designed to accelerate drying times for lettering enamels, bulletin colors, and pearlescent enamels. 1-Shot Hardener will extend color life, increase gloss, and improve adhesion to most substrates. Adding 1-Shot Hardener to paint will also aid in preventing "lifting" when over coating with an automotive-style clear coat system.

Shelf Life: Unopened: 48 Months Opened: 12 months



SKU	SIZE
4007	Pint

1-Shot Brush Conditioner & Cleaner

A premium brush cleaner designed to not only thoroughly clean oil based paints from quality, natural hair brushes, but to do so without damaging the hair of the brush. Unlike harsh spirits and reducers, this product conditions, and softens the brush and can even be used to restore partially hardened natural & nylon brushes; all without interfering with the properties of oil based sign paints.

Shelf Life: Unopened: 48 Months Opened: 12 months



SKU	SIZE
4004	Quart

1-Shot Low Temp. Reducer

Formulated to improve flow and leveling at low temperatures by reducing viscosity and accelerating the evaporation process without significantly reducing the quality of the coating. *6001 Low Temp Reducer is ideal for spray & airbrush applications.

Shelf Life: Unopened: 72 Months Opened: 72 months



SKU	SIZE
6001/QT	Quart

1-Shot High Temp. Reducer

6002 High Temperature Reducer is formulated to improve flow and leveling at high temperatures by reducing the viscosity and accelerating the evaporation rate without significantly altering the quality of the coating being reduced. (85 Degrees and Above) These reducers are engineered for use with 1 Shot products and should always be used, as opposed to mineral spirits, turpentine or other less than compatible reducing agents.

Shelf Life: Unopened: 72 Months Opened: 72 months



SKU	SIZE
6002/QT	Quart

1-Shot Speed Dry UV Acrylic

A fast drying acrylic clear topcoat designed to prevent color fade, UV depletion and mild abrasion on printed vinyls and print media. Speed Dry UV Acrylic Clears also serve well as edge sealers on multi-layered vinyls, PVC, PVF and metallized polyester films. *Speed Dry UV Acrylic Clears are not recommended for use on vehicle graphics.

Shelf Life: Unopened: 48 Months Opened: 12 months



SKU	SIZE
4005/A	Spray
4005	Quart

Chromatic Clear Flattening Paste

Mixing with 1 Shot Lettering Enamels or Chromatic Bulletins, Clear Flattening Paste will modify gloss levels for both interior and exterior use. A 1:1 mix ratio will result in a nearly dead flat finish, with lesser amounts yielding varying degrees of gloss ranging from semi-gloss to eggshell.



SKU	SIZE
V9500-QT	Quart

1-Shot Ti-Cote Clear Primer Barrier Coat

A waterborne primer/barrier intended for use on most flexible synthetic fabrics including untreated (non-ERC) banner materials, canvas, leather, leatherette, naughyde and most synthetic awning fabrics. Ti-Cote is milky white when applied, but dries clear and is generally ready to paint in 1-2 hours.

Shelf Life: Unopened: 48 Months Opened: 12 months



SKU	SIZE
TI-COTE	Quart

Lettering Quills

Grey or Brown lettering quills are made of the finest selected camel hair, brass wire bound by skilled French Artisans for many generations. All sizes of this brush are made of 100% pure grey Talahutky or brown Kassane squirrel hair and are noted for their uniformity, resiliency and clean square edges.

Brown

SKU	SIZE	HAIR LENGTH
3010-1	1	1 ¼"
3010-3	3	1 ¼"
3010-5	5	1 ¼"
3010-7	7	1 ¼"
3016-1	1	1 ½"
3016-3	3	1 ½"
3016-5	5	1 ½"
3173-1	1	¾"
3173-2	2	⅞"
3173-3	3	⅝"
3173-5	5	1 ⅙"
3173-7	7	1 ¼"
3173-8	8	1 ⅝"
3173-10	10	1 ⅜"
3173-12	12	1 ⅞"
3173-14	14	1 ½"
3173-16	16	1 ⅞"
3173-18	18	1 ⅝"
3173-20	20	1 ⅝"



Gray

SKU	SIZE	HAIR LENGTH
3012-1	1	¾"
3012-2	2	⅞"
3012-3	3	1 ⅙"
3012-5	5	1 ⅙"
3012-7	7	1 ¼"
3012-9	9	1 ⅜"
3012-10	10	1 ⅜"
3012-12	12	⅞"
3012-14	14	1 ½"
3012-18	18	1 ⅝"

Fitch Brush

Bristle is hand cupped to slanting, straight edge. Round, lacquered handle with rustproof, seamless nickel plated brass ferrule. Approximate overall length: 12 inches.

SKU	QTY
2258-1-1/2	1 ½" Angular - French White



Truck Flat Lettering Brush

Pure grey Talahutky, brown Kassane and finest OX hair blended to produce the finest lettering stroke brush available. Contains no synthetics. Seamless nickel plated ferrule on black polished handle. Overall length approximately 9 inches.

SKU	SIZE
2184GX-1/4	Truck ¼"
2184GX-3/8	Truck ⅜"
2184GX-3/4	Truck ¾"
2184GX-1	Truck 1"



Sword Striping Brush

Finest quality pure selected squirrel hair in lacquer resistant setting with brass wound ferrule and a German craftsmanship. A very good blend of quality and value.

SKU	SIZE
2223-0	Striper #0 Sword ⅝"
2223-00	Striper #00 Sword ¼"
2223-1	Striper #1 Sword 1 ⅜"
2223-2	Striper #2 Sword ⅞"
2223-3	Striper #3 Sword ½"



Striping Quill

Made of pure Brown Kazan squirrel hair, Brass wire bound to natural and plastic ferrules attached to black handles. **2" brush lengths makes it perfect for lining and striping.**

SKU	SIZE
3017-1	1 x 2"
3017-2	2 x 2"
3017-4	4 x 2"
3017-6	6 x 2"



Acid Brush Size 2 (1/2")

Use for gluing, pasting, soldering or acid application. Very popular where one time usage is necessary. Horsehair bristle is held in place by staple and is double crimped. Standard box is 144 pieces. Width: 1/2" Trim Length: 3/4" Overall Length: 6"

SKU	QTY
P15	1 box - 144 pcs



Touch-Up Brush

A very popular touch-up, lacquering or general purpose brush used extensively for industrial applications. Hair is securely set in solvent resistant epoxy. Seamless aluminum ferrule on plain white wood handle. 7 inch overall.

SKU	SIZE
7764-1	1" x 1 3/16"
7764-1/2	1/2" x 3/4"
7764-1/4	1/4" x 9/16"
7764-1/8	1/8" x 1/2"



60W Chip Brush

Pure white china bristle **disposable** paint and chip brush. Valuable multi-purpose chip, paint, touch up or gluing brush. Features bristles securely set in epoxy for solvent resistance.

SKU	SIZE
60W-1	1" Chip Brush
60W-2	2" Chip Brush
60W-3	3" Chip Brush
60W-4	4" Chip Brush



The 60W Chip Brush is packaged 36 each per box FOR ALL SIZES.

Poly (Foam) Brush®

Ideal for application of enamel, latex, oil paints, stain or varnish. Economical disposable applicator. Easy to use with professional results. Smooths out paint and cover correctly with fewer strokes eliminating brush marks and loose bristles.

SKU	SIZE
P1401	1" Poly-Brush®
P1402	2" Poly-Brush®
P1403	3" Poly-Brush®
P1404	4" Poly-Brush®



The Poly-Brush® is packaged 48 each per box FOR ALL SIZES.

Poly (Foam) Roller Cover®

Less spatter with optimum surface coverage. Easy to use with professional results. Environmentally friendly.

SKU	SIZE
217-3	3" Poly-Roller®
217-4	4" Poly-Roller®
217-9	9" Poly-Roller®



The Poly-Roller® is packaged 24 each per box FOR ALL SIZES.

PVC Edge Caps

Designed to be used with various sign substrates.

These durable edge caps definitely will give life to the perimeter of your signs, giving them a smooth and professional look. This short edge cap also makes it easy to conform to any letter! Choose from a variety of attractive colors to accent the perimeter of your sign.

COLOR	D1	D2	LENGTH	SKU
Black	1/4"	1/4"	98'	50199-98/BLK
Black	1/2"	3/8"	98'	50203-98/BLK
White	1/4"	1/4"	98'	50200-98/WHT
White	1/2"	3/8"	98'	50201-98/WHT
White	3/4"	3/8"	98'	50226-98/WHT
White	3/8"	3/4"	98'	50250-98/WHT
Blue	1/4"	1/4"	98'	50208-98/BLU
Blue	1/2"	3/8"	98'	50217-98/BLU
Red	1/4"	1/4"	98'	50230-98/RED
Red	1/2"	3/8"	98'	50231-98/RED
Green	1/2"	3/8"	98'	50229-98/GRN

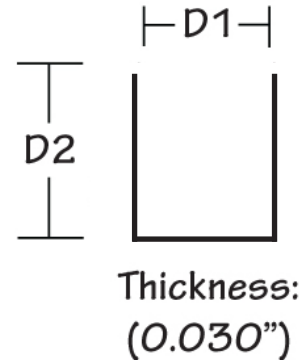

See next page for 90° Hand Notches for perfect 45° corners.

Letter Trim

Sold individually, this is a professional clean and stylish Letter Trim. This trim is a plastic molding that adds a new dimension to cut-out letters. Its form fits to any style letter, Gothic, Roman or Script etc. No painting or polishing necessary.

COLOR	SIZE	LENGTH	SKU
Black	1"	10' Length	SRT-1-BLK
Black	2"	10' Length	SRT-2-BLK
Black	1"	150' Reel	1R-BLACK
Black	2"	150' Reel	2R-BLACK
White	1"	10' Length	SRT-1-WHITE
White	1"	150' Reel	1R-WHITE
White	2"	10' Length	2R-WHITE
White	2"	150' Reel	SRT-2-WHITE
Blue	1"	150' Reel	1R-BLUE
Blue Intense	1"	150' Reel	1R-BLU-INTENSE
Bronze	1"	150' Reel	1R-BRZ
Chrome	1"	150' Reel	1R-CHROME
Chrome Brush	1"	150' Reel	1R-CHR-SAT
Gold	1"	150' Reel	1R-GOLD
Green	1"	150' Reel	1R-GREEN
Red	1"	150' Reel	1R-RED
Red	2"	150' Reel	2R-RED
Silver Metallic	1"	150' Reel	1R-SILV-MET

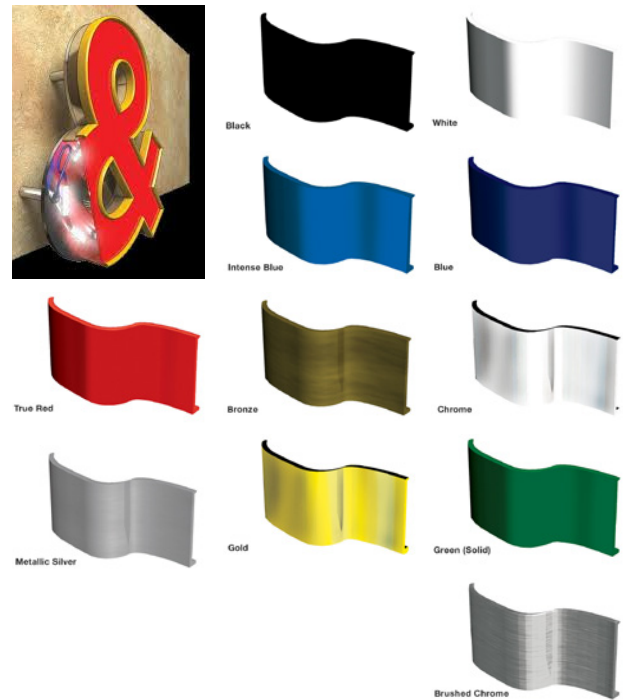

Black Aluminum "J" Molding

1 3/8" x 1/4" x 24' 5" Lengths

Originally designed to finish aluminum tube frame signs, but can be used on any type of signage. .0625" - 1/16" Thickness.

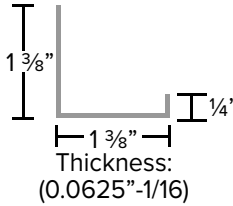

SKU	COLOR
1943/BLK	Satin Black

Clear Aluminum "L" Molding

3/4" x 1" x 21' Lengths

Suitable for edge finishing of interior and exterior signage. Designed to retain various sign faces. .0625" - 1/16" Thickness.

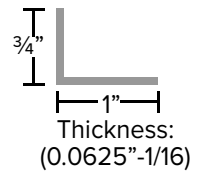

SKU	COLOR
994440CLR	Clear

Econo Aluminum Retainer Molding

SKU	COLOR
2056	Bronze

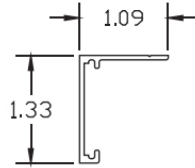

Standard 2Part Retainer Molding

SKU	COLOR
1944	Bronze

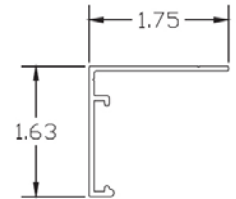

Aluminum "U-Cap" Edge Cap (1/8" Opening x 1/2" Face x 96" Long)

Our "U-Cap" Aluminum Edge Cap is available in 1/8" Black or White only. These durable edge caps definitely will give life to the perimeter of your signs, giving them a smooth and professional look. This edge-cap has a 1/2" Gloss face and can only be used on 1/8" substrates.

SKU	COLOR
1009-BLK	Black
1009-WHT	White

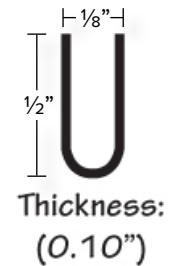

Chrome Aluminum Tubing 1" x 1" x 21' x .031

To be used for framing aluminum tube frame signs. Size: 1" x 1" Thickness: .031 Length: 21 feet Finish: Mill

SKU	FINISH
211/TUBE	Mill



Hand Notcher

Designed for notching 90° up to 20 gauge mild steel with minimal effort. This notcher is capable of a 1"-- depth of notch featuring a built-in metal stop.

SKU	ANGLE
NOTCHER-MOD	90°



SIGN HERO 360

DOUBLE-SIDED LED SIGN TUBE



DIRECT DRIVE TECHNOLOGY NO POWER SUPPLIES NEEDED!

Introducing Keystone's 360° LED Sign Tube: The easiest LED installation



A perfect solution for retrofits or new sign installations. **With revolutionary DirectDrive technology there's no need for an external driver or ballast, saving precious labor time and costs.** Maintenance professionals install the 360° LED Sign Tube in five minutes or less!

6" Depth from face to lamp - 12" standard spacing
Quick and easy installation

Our DirectDrive technology eliminates the need for an external driver or ballast while still using existing sockets. This saves time and hassle for field technicians.

Consistent lighting

We've added optical lenses to cover each individual LED chip in the tube, which eliminates hot spots and ensures consistent light distribution across both faces of the sign.

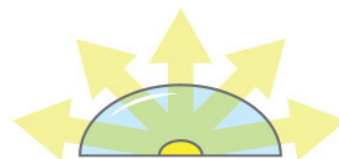

**Wide light distribution = No shadowing
No hotspots**

Flexible for your needs

We've provided a rotatable R17D end cap that swivels, ensuring that the tube can be adjusted to provide a light beam in any direction.

Built to last

Count on Keystone for a tube with a **50,000 hour lifetime and a 5 year warranty.** Heavy duty aluminum heatsink ensures LEDs run cooler for longer. Plastic and aluminum construction ensures less breakage.



**See additional information
on the following page**

**For installation video visit
keystonetech.com/video**

**ROTATABLE
CASE
R17D**

**Standard 6 lamp, 8' sign with magnetic ballast*



Double Face Lamps Available for All Size Sign Cabinets

The 360° LED Sign Tube is available in all of the lamp lengths typically used to replace T8HO & T12HO fluorescent lamps, including:

Part Number	Nominal Length	Wattage	Color Temp	Total Lumens	Lumens Per Side
A-18-6500K-DS	18"	7	6500K	900	450
B-24-6500K-DS	24"	10	6500K	1200	600
C-30-6500K-DS	30"	13	6500K	1600	800
D-36-6500K-DS	36"	16	6500K	2000	1000
E-42-6500K-DS	42"	18	6500K	2250	1125
F-48-6500K-DS	48"	21	6500K	2600	1300
G-60-6500K-DS	60"	26	6500K	3250	1625
H-64-6500K-DS	64"	28	6500K	3450	1725
I-72-6500K-DS	72"	31	6500K	4000	2000
J-84-6500K-DS	84"	37	6500K	4700	2350
K-96-6500K-DS	96"	42	6500K	5300	2650
L-108-6500K-DS	108"	47	6500K	5800	2900
N-117-6500-DS	117"	50	6500K	6200	3100
M-120-6500K-DS	120"	52	6500K	6400	3200

SINGLE FACE LAMPS & 4000K COLOR TEMP AVAILABLE. SPECIAL ORDER ONLY

Bypass the ballast for the fastest installation.

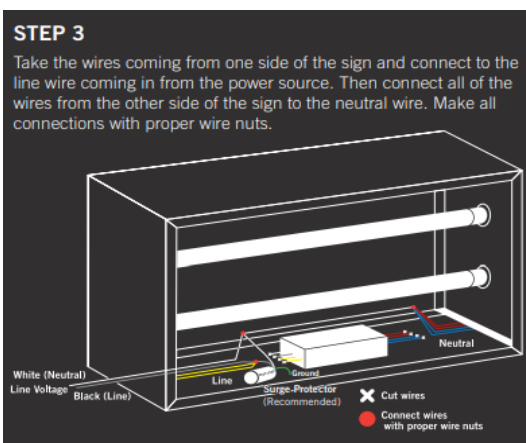

Allanson LEDgen2 Standard LED Module

- 160° Beam angle for shallow lighting
- Balanced and uniform illumination
- Fast and easy installation
- Excellent module efficacy
- Fewer Modules required for lower installation cost
- Consistent color
- Product can be used in dry/damp and wet locations (not suitable for submersed applications) IP67
- Available in **0.5W** and **1W** in White
- 2 modules per foot
- UL recognized
- RoHs compliant



AVAILABLE IN 0.5 WATT & 1 WATT

Modules Population Recommendation*

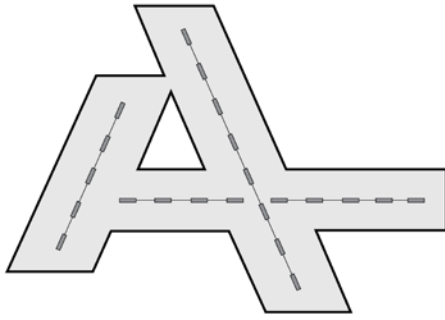

Recommended Depth (2 Modules/Foot)	Stroke Spacing Range
4 inches	6 - 7 inches
5 inches	8 - 10 inches
6 inches	10 - 12 inches
8 inches	12 - 14 inches

*Results may vary based on sign face material, graphics, and desired brightness.

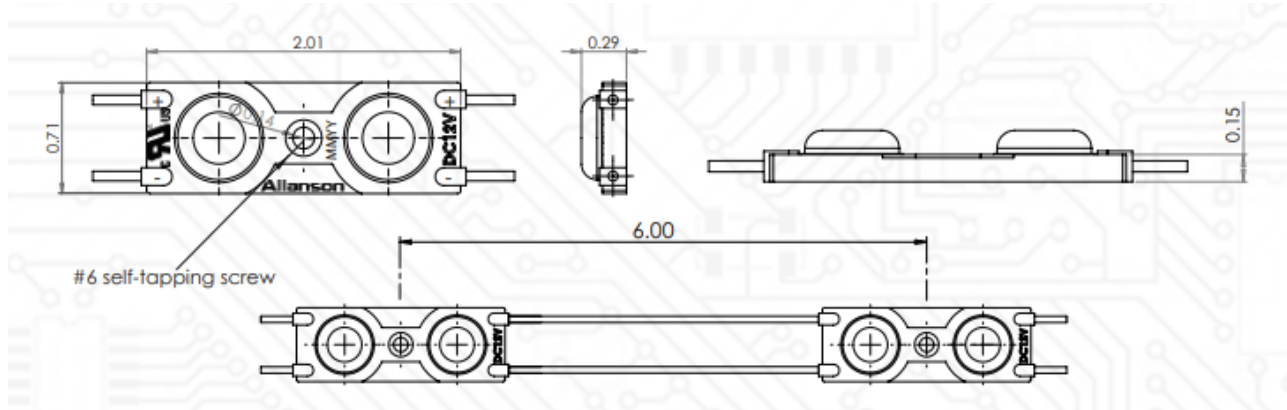

Power Supply Loading Information

SKU	Wattage	Number of Modules		Number of Feet	
		S05W2CWII-16OD	S1W2CWII-16OD	S05W2CWII-16OD	S1W2CWII-16OD
CV122-120-277MV	24	43	20	21.5	10
CV125-120	60	108	50	54	25
CV125-MV	60	108	50	54	25
CVL2125-120-227	2 x 60	108 + 108	50 + 50	108	50

Allanson ECONO MODULE

12V Economy modules are 7000K, and are rated for lightbox and channel letter use. These have a 160 degree beam angle. Modules are not to be placed on 12" row centres, they typically require 6" to 10" row spacing depending on depth of letters.

NEW!**SKU****V07W2TWB-7000K**

Specifications

Color Temperature	7000K
LED/Mod	2
Mod/Ft	2
Lumens/Mod	65
Lumens/Ft	130
Lumens/Watt	85
Beam Angle	160
Power Consumption	0.75W
Input Voltage	DC 12V
Operating Temperature	-30° C to +60° C
IP Level	67

Packaging

Anti-Static Bag	72 Modules
Carton	864 Modules
Master Carton	1728 Modules
Warranty	3 Years

Power Supply Loading Information

SKU	Wattage	Number of Modules	Number of Feet
CV122-120-277MV	24	28	14
CV125-120	60	72	36
CV125-MV	60	72	36
CVW12125-MV	2x60	72 + 72	72

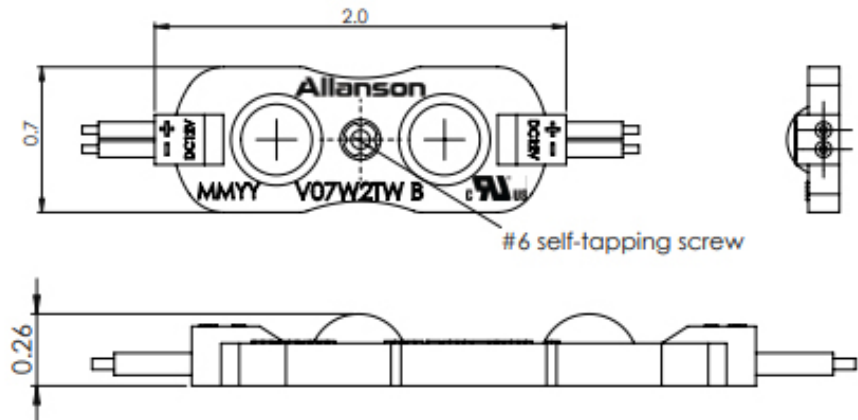

Modules Population Recommendation*

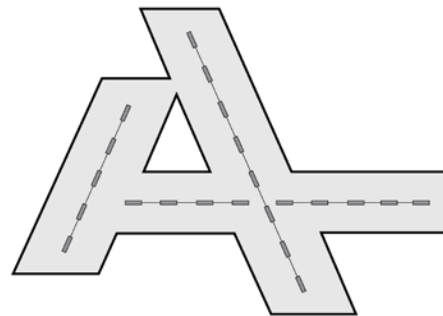

**Recommended
Depth
(2 Modules/Foot)**

**Stroke Spacing
Range**

4 inches	6 inches
6 inches	9 inches
8 inches	10 inches

*Results may vary based on sign face material, graphics, and desired brightness.

Helpful Tip!

Under-powering LEDs does not have an affect on the LED Modules or Power Supplies. Over-powering has a direct effect on LED Modules and Power Supplies.

LED

LEDS FOR CHANNEL LETTERS

Allanson **LEDgen2** Mini LED Module

NEW!

- Designed to fit 1/2" narrow stroke and 1.5" shallow signs
- Provides flexibility and versatility while making a big impact
- 160° beam angle
- Balanced and uniform illumination
- Fast and easy installation
- Excellent module efficacy
- Fewer Modules required for lower installation cost
- Consistent color
- Product can be used in dry/damp and wet locations.
- (Not suitable for submersed applications) IP67
- UL recognized



SKU	S03W2CWBM
------------	------------------

Specifications	
Color Temperature	6500K
LED/Mod	2
Mod/Ft	4
Lumens/Mod	37
Lumens/Ft	148
Lumens/Watt	95
Beam Angle	160°
Power Consumption	0.3W
Input Voltage	DC 12V
Operating Temperature	-30° C to +60° C
IP Level	67

Packaging	
Anti-Static Bag	100 Modules
Carton	2500 Modules
Master Carton	5000 Modules
Warranty	5 Years

Power Supply Loading Information			
SKU	Wattage	Number of Modules	Number of Feet
CV122-120-277MV	24	28	14
CV125-120	60	72	36
CV125-MV	60	72	36
CVW12125-MV	2 x 60	72 + 72	72

Modules Population Recommendation*

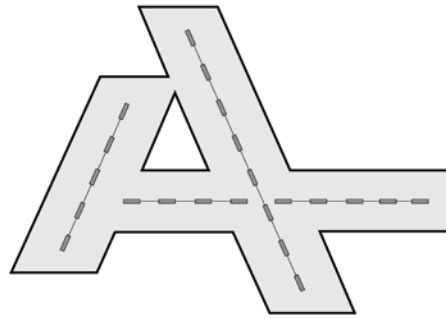

Recommended Depth	Max Stroke (Single Row)	Row Spacing (Multi-Row)
1 inch	1.5 inches	2 inches*
1.5 inches	2 inches	2 inches
2 inches	4 inches	3 inches
3 inches	6 inches	5 inches
4 inches	6 inches	6 inches
5 inches	6 inches	6 inches

*6 modules/foot
Results may vary based on sign face material, graphics, and desired brightness.

Helpful Tip!
The lower the load on LED Power Supplies, the longer they will last. Always load LED Modules to the recommended manufacturer's power supply loading chart.

Allanson Low Profile LED Module

Allanson's new low profile LED module, designed with optimal batwing lens for 1.5 - 4" shallow signs, provides brighter and even illumination that can allow you to install 2 modules per foot, reducing your installation time and cost!



.73 WATT (LOW PROFILE)

SKU

S07W2CWBLP170D

Specifications

Color Temperature	6500K
LED/Mod	2
Mod/Ft	2
Lumens/Mod	70
Lumens/Ft	140
Lumens/Watt	96.1
Beam Angle	170
Power Consumption	0.73W
Input Voltage	DC 12V
Operating Temperature	-30° C to +60° C
IP Level	67

Packaging

Anti-Static Bag	72 Modules
Carton	864 Modules
Master Carton	1728 Modules
Warranty	5 Years

Power Supply Loading Information

SKU	Wattage	Number of Modules	Number of Feet
CV122-120-277MV	24	28	14
CV125-120	60	72	36
CV125-MV	60	72	36
CVW12125-MV	2x60	72 + 72	72

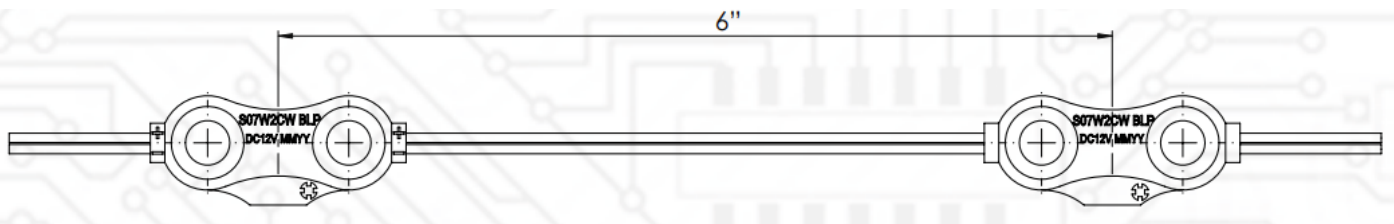
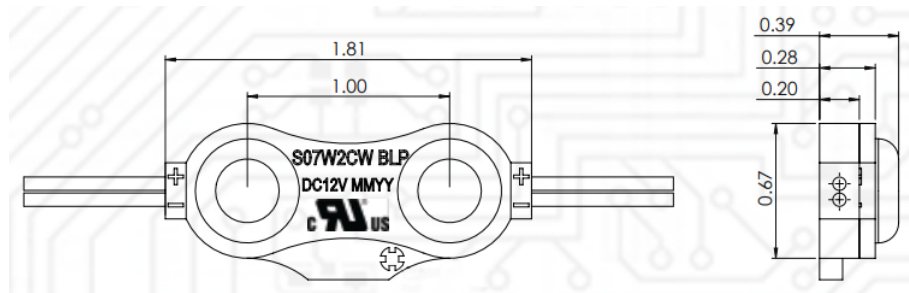

Modules Population Recommendation*

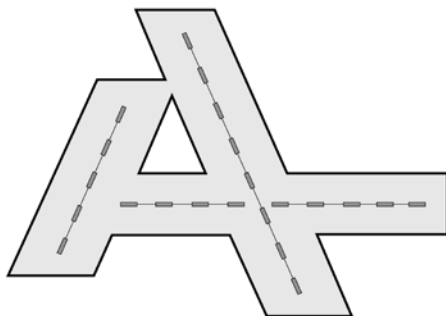

Recommended Depth (2 Modules/Foot)

Stroke Spacing Range

1.5 inches**	3 inches
2 inches***	4 inches
2.5 inches	5 inches
3 inches	6 inches
4 inches	8 inches

*Results may vary based on sign face material, graphics, and desired brightness. ** 4 modules/foot ***2.5 modules/foot

JS LED STANDARD The perfect LED for use in *wide* and *narrow* stroke letters

- 3 Modules per Foot - 3/8" x 1 1/4" Modules
- Electrical characteristics: TA=25°C
- 12 VDC Super bright LED
- Easy and flexible installation
- High brightness, wide angle LED chip
- Ideal for home and business lighting decoration
- Low power consumption
- 3 Year Limited Warranty

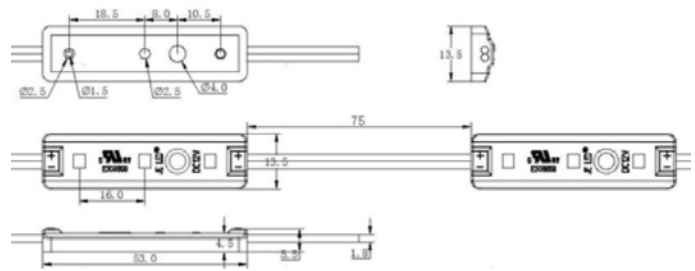

.36 WATT

Specifications

Part Number	JE-001R-24	JE-002G-11	JE-003B-24	JE-004CW-05L
Color	Red	Green	Blue	Cool White
LED Size	2835	3528	3528	2735
Protection	IP68	IP65	IP65	IP68
Viewing Angle	120° ± 5	120° ± 5	120° ± 5	120° ± 5
Forward Voltage	12V	12V	12V	12V
Forward Current	60mA	30mA	30mA	30mA
Wavelength	623nm	523nm	523nm	9000K
Luminous Flux	16LM	17LM	17LM	33LM
Power Consumption	0.36W	0.36W	0.36W	0.36W
Operating Temperature	-25°C - +70°C	-25°C - +70°C	-25°C - +70°C	-25°C - +70°C

JS LED Power Supply Loading

Description	Item Number	20 Watt Total Modules	40 Watt Total Modules	60 Watt Total Modules	Watt Per Modules
Standard Red	JE-001R-24	38/15ft	75/30ft	115/46ft	.42
Standard Cool White	JE-004CW-05L	38/15ft	75/30ft	115/46ft	.42
Standard Green	JE-002G-11	38/15ft	75/30ft	115/46ft	.42
Standard Blue	JE-003B-24	38/15ft	75/30ft	115/46ft	.42

Skyline Rigid Border Tubing

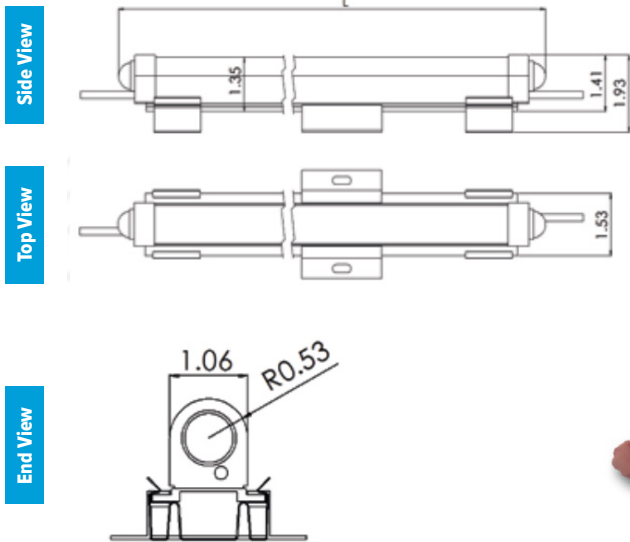

Installation hardware included, but not attached.

Call for Availability & Pricing on Standard Premade Lengths & Sizes!

Standard Colors:

Red - Yellow - Lemon - Orange
Cool White - Blue - Green



Allanson's LED SkyLine Rigid Border Tubing provides top of the line LED systems that complement and enhance the appearance of your building.

With superior accent lighting, the sky's the limit!

- Seven standard colors (custom colors upon request*)
- RGB SkyLine also available for color changing effects
- Balanced even illumination - no dead spots
- Non-bendable, UV resistant polycarbonate housing
- Sturdy stainless steel snap clip and aluminum slide attachments for easy mounting
- Dimmable (LED Dimmer ACL-12/24V- DMR)
- Standard and custom lengths available
- 5 year standard warranty
- 24 VDC System
- Field Cutting Kit (#ARBT-CUTKIT) only available for seven standard colors to assist with on site adjustments
- Clean connection - wires are securely & effectively retained behind tubing
- UL & CUL listed outdoor & indoor wet, damp, & dry location
- Operating temperature: -40°C to 70°C
- White is 6000K, 122 Lumens per foot
- Uses Allanson CVW243-MV (waterproof) or CV244-120-277 Power Supplies
- IP 67 rated

Call For Sizes & Pricing!

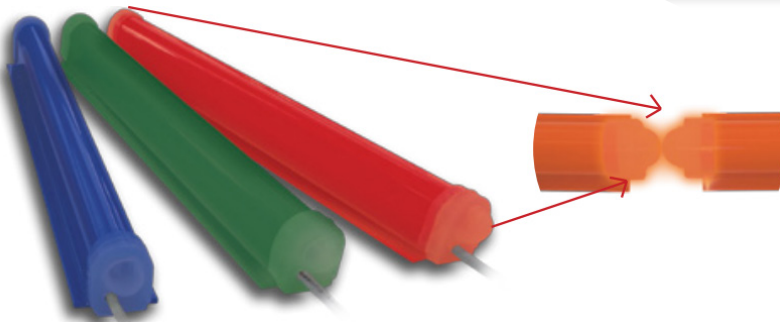

RGB

End caps allow for thermal expansion and contraction and provide uniform illumination from end to end for a clean and sleek look.

LED

RGB3 SYSTEM MODULE FOR CHANNEL LETTERS

RGB3 System

Has predetermined programs to select from to meet your needs. Cannot be changed or customized.

- Tricolor emitter is brighter and more efficient
- Pre-set programs
- Time delayed program capability
- DMX programming and signal capability
- Maximized sign awareness in any environment
- 3 larger light sources versus 9 individual point sources
- Fewer power supplies required to light the same sign
- We can pre-program the system to your specifications
- You can easily program the system in your facility
- Program on site using Allanson's exclusive design software

Call For Sizes & Pricing!



Specifications

Part Number	ACLW-RGB3
LED Channels	Red, Green, Blue
Input Voltage	DV 12V
Power Consumption/Mod	0.72W
Beam Angle	110°
Dimensions	2.93" x 0.75" x 0.25"
Mod/Foot	2.5
Max Mod/60W Power Supply	75
Operating Temperature	-30°C - +60°C
Environmental Rating	IP 67
Warranty	5 Years

Loading Recommendation

CV122-210-277MV (24W)	30 Modules
CV125-MV (60W)	80 Modules
CV125-120 (60W)	80 Modules
CVL2125-120-227 (2x60W)	80 + 80 Modules

Packaging

Single Unit (Various Size)	25
Bulk Packaging	600

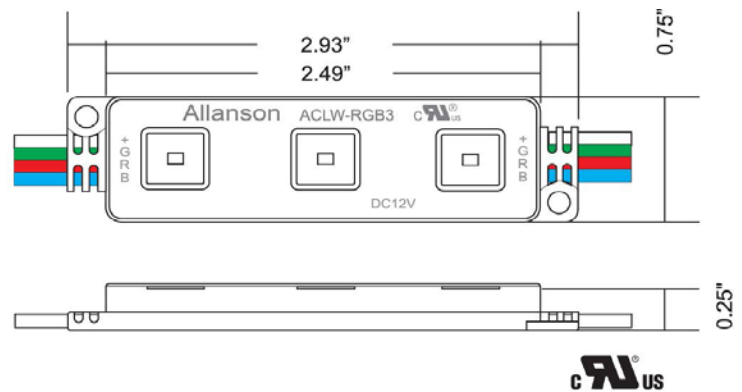

2,940 Allanson RGB DMX Modules were installed in the Argosy sign.

Allanson RGB DMX Modules can be programmed to allow each letter to change a different color, all letters to change the same color at the same time, colors to fade from one letter to the next, colors to change in reverse, or flash if desired.

One of the color schemes currently programmed allows Argosy to display the colors of the American Flag. Each Argosy letter goes through a sequence where they change from blue to red to white and then back again.

DMX & WiFi Controllers - *For RGB Skyline & RGB3 System*

Master Controllers

ACL-PPMC-DMX

- Pre-programmed DMX Master Controller
- 16 sub-controller capability RGB Pre-Programmable Master Controller
- 32 preset programs available
- Microphone for sound control
- Speed and intensity can be adjusted
- Develop your own color with 255 level of each red, green, and blue
- Maximum distance from DMX master controller to sub-controller is 200 ft
- Dimensions: 3.82" L x 2.36" W x 1.57" H



ACL-MC-DMX

- DMX Master Controller
- 512 Channel, 170 sub-controller capability ACL-MC-DMX
- Links sub-controllers together
- Multiple signs can be addressed individually
- Stores up to 32 user defined programs
- Uses DMX 512 protocol signal via XLR interface
- USB programming interface
- Can be powered by 120 Volt AC adapter (included) or USB port (optional)
- Day, hour and minute time setting capability
- 120 Volt AC power adapter included
- Speed, fade and strobe adjustable
- Maximum distance from DMX master controller to sub-controller is 200 ft
- Dimensions: 7.125" L x 4.75" W x 1.56" H



Sub-Controllers

ACL-SCD120-DMX

- Runs up to 75 modules of RGB3 DMX System or 12 ft of RGB SkyLine Rigid Border Tubing
- Uses economical 12 VDC or 24 VDC Class 2 power supplies
- 5 built in dip switch preset programs
- Operates independently or as part of system
- Dimensions: 4.06" L x 2.625" W x 1.125" H



WiFi Controller

ACL-WIFI-103

- Controls up to 75 modules of RGB3 System or 12 ft of RGB SkyLine Rigid Border Tubing
- Power Amplifier ACL-3063-3A can control an extra 75 modules per unit or extra 12w ft of RGB SkyLine Rigid Border Tubing with the same lighting effects
- Stand-alone Non-DMX system
- Maximum WiFi control distance is 320 ft using the smart phone app
- Numerous variables/interferences may influence wireless distance
- Max RF transmission distance is 95 ft line of sight via remote control
- 32 preset programs and 9 user defined colors via remote control
- Remote control sold separately
- Dimensions: 5.02" L x 2.87" W x 1.75" H



ALL ITEMS LISTED ARE SPECIAL ORDER ONLY.

Controllers - **For RGB ADDRESSABLE**

Addressable Controller (ACL-ADC-SPI)

- Enormous capability of controlling up to 21000 modules
- 14 Programs can be stored with SD card
- Day, hour, and minute time setting capability
- Operates independently without sub controller
- Maximum distance from controller to first module or between modules is 60 ft
- 120 Volt AC power adapter, channel adapters, jumper cables, and SD card and SD card reader included
- Dimensions: 7.75" L x 4.72" W x 1.85" H



DMX Master Controller (ACL-MC-DMX) AND Signal Converter from DMX to SPI (ACL-DMXSPI)

- Capability of controlling up to 170 modules
- Stores up to 32 user defined programs
- Day, hour, and minute time setting capability
- DMX 512 protocol signal via XLR interface
- Speed, fade, and strobe adjustable
- USB programming interface
- Can be powered by 120 Volt AC adapter (included) or USB port (optional)
- Maximum distance from converter to first module or between modules is 60 ft
- Maximum distance from DMX master controller to converter is 200 ft
- **Dimensions (A): 6.89" L x 2.05" W x 1.30" H**
- **Dimensions (B): 7.13" L x 4.75" W x 1.56" H**



Addressable Pre-Programmed Controller (ACL-ADPPC)

- Controls from 8 to 360 modules
- 16 Preset Programs
- Adjust speed, direction and fade
- Compact size
- Speed, direction, fade, and strobe are adjustable
- Maximum RF transmission distance is 130 ft line of sight
- Wireless remote and 120 Volt AC power adapter included
- Maximum distance from controller to first module or between modules is 60 ft
- Dimensions: 5.30" L x 1.18" W x 0.79" H



ALL ITEMS LISTED ARE SPECIAL ORDER ONLY.

ACCESSORIES

Note: signal cable(CAT-5) not supplied.

RGB Signal Booster (ACL-RGB-CATV-BOOSTER)*

- Boosts the DMX signal and extra 400 ft when used with the Allanson Signal Cable for an extra 200 ft when used with the CAT5 Cable

Dimensions: 5.25"L x 2.75"W x 2"H



DMX512/Network Converter (ACL-ARTNET-DMX)*

- Sending DMX signal over IP networks
- Can be configured in two ways: DMX512 to Network or Network to DMX512

Dimensions: 7.80"L x 3.07"W x 1.97"H



DMX512/Network Converter (ACL-ARTNET-OPENID)*

- Safe as ACL-ARTNET-DMX, except open IP range configuration

Dimensions: 5.12"L x 2.36"W x 1.58"H



SPI Signal Amplifier and Splitter (ACL-SPI-SA)

- Extends the SPI signal distance an extra 100 ft when used with the Allanson Signal Cable or an extra 60 ft when used with the CAT5 cable

Dimensions: 4"L x 1.25"W x 1.25"H



Power Amplifier (ACL-3063-3A)

- IP68 Waterproof
- Constant Voltage power amplifier
- Duplicates RGB signal
- Multiple amplifiers can be used

Dimensions: 6.42"L x 1.38"W x 1.10"H



Signal Cable (ACL-DMX-CBL-100)

- Shielded 3 wire signal cable
- 100 ft per spool



ACCESSORIES FOR WIRELESS

Note: Numerous variables/interferences may influence wireless distance.

WIRELESS OPTIONS BETWEEN CONTROLLERS

DMX Wireless Kit (ACL-DMX-WLS)*

- Wireless DMX signal transmitter and receiver with 3 pin XLR connector
- Max 320 ft wifi signal range for open area



DMX Wireless Receiver (ACL-DMX-WLS-RECEIVER)*

- Wireless DMX signal receiver works with ACL-DMX-WLS transmitter
- Multiple receivers can be used with one transmitter



WIRELESS OPTIONS BETWEEN MODULES

PWM RF Transmitter (ACL-WT3050)*

- 2.4 GHz working frequency
- Max wireless distance is 320 ft open area

Dimensions: 7"L x 2.20"W x 1.22"H



PWM RF Receiver (ACL-WR3053-5A)*

- Multiple receivers can be used to sync with one transmitter
- 2.4 GHz working frequency
- Max wireless distance is 320 ft open area

Dimensions: 7"L x 2.20"W x 1.22"H



WIRELESS OPTIONS FOR ACL-WIFI-103

Remote Control for ACL-WIFI-103 (ACL-T3-RC)*

- Full color touch panel
- RF transmission distance is 95 ft line of sight
- 32 preset programs & 9 user defined colors

Dimensions: 6.61"L x 3.78"W x 1.34"H



Constant Voltage Receiving Controller for ACL-WIFI-103 (ACL-DMX-WLS-RECEIVER)*

- Wireless receiver with built-in antenna
- Max wireless distance is 200 ft open area

Dimensions: 7"L x 1.90"W x 1.30"H



ALL ITEMS LISTED ARE SPECIAL ORDER ONLY.

*NON WEATHERPROOF

Allanson Power Supply

A CVL2125-120-227

Dry & Damp Location WITHOUT NPT Threaded Nipple/Coupling

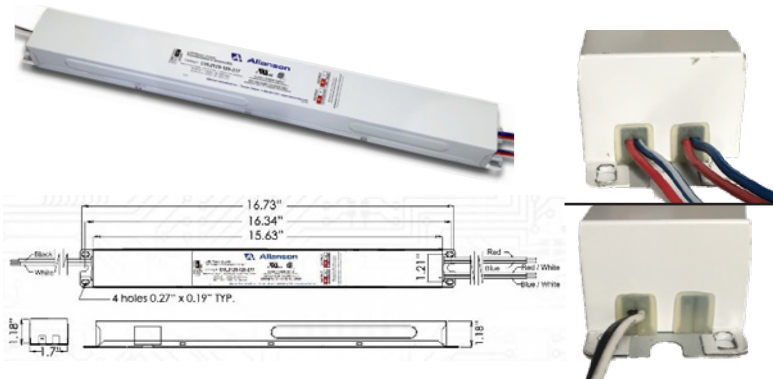

B CV125-120

Dry & Damp Location WITHOUT NPT Threaded Nipple/Coupling

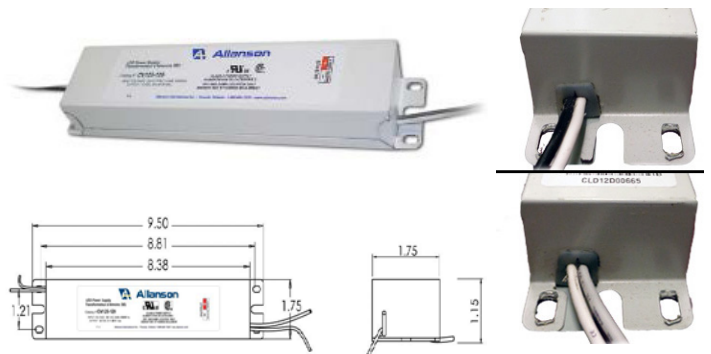

C CV125-120-277

Dry & Damp Location WITHOUT NPT Threaded Nipple/Coupling

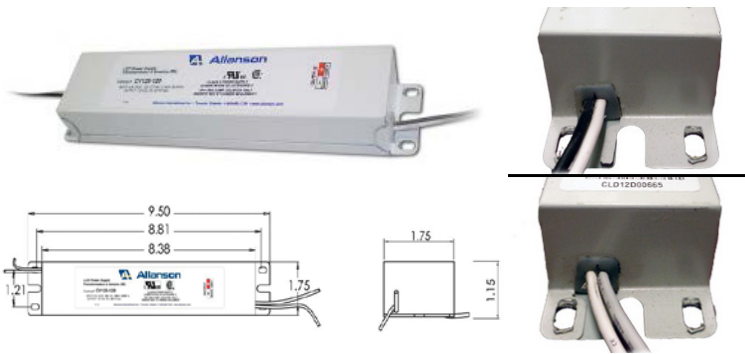

D CVW125-120-277

Dry, Damp & Wet Location WITH 1/2" NPT Male Thread at Both Ends

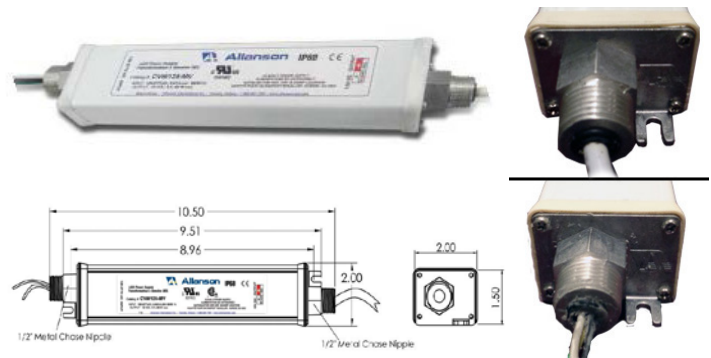

E CV244-120-277V

Dry & Damp Location WITHOUT NPT Threaded Nipple/Coupling

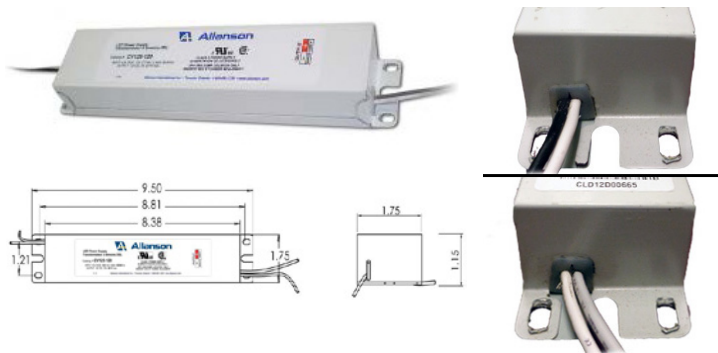

Product Features

- Suitable for LED sign lighting and signage retrofit kits
- Overload and short-circuit protected
- Operating temperature -40°C to 40°C (reduce loading if exceeds 40°C)
- Fully encapsulated
- High Power Factor & Short circuit protection
- UL Class 2 rated
- CSA Components certified
- 5 year standard warranty

Item	Part Number	Input Voltage	Input Current Amps	Output Volts	Output Current	Output Watts	Location
A	CVL2125-120-227	120-277	1.25A	12	2 x 5.0	2 x 60	Dry & Damp
B	CV125-120	120	0.61A	12	5.0	60	Dry & Damp
C	CV125-120-277	120-277	0.29A	12	2.0	24	Dry & Damp
D	CVW125-120-277	120-277	0.65A	12	5.0	60	Dry, Damp & Wet
E	CV244-120-277V	120-277	1.04A	24	4.0	96	Dry & Damp

Universal Power Supply 60W/120-277VWT

Dry, Damp & Wet Location WITH 1/2" NPT Female Thread at Both Ends

Universal's new Q-Can driver is designed to simplify installation and provide long dependable life in tough applications. The 12V LED driver with a 60W class 2 output is designed specifically for demanding outdoor signage applications.

The Q-Can comes with threaded adapters that allow connection to junction boxes either directly with couplers or through sections of conduit. This keeps all the electrical connections enclosed to comply with code requirements and eliminates the need for additional enclosures. The jacketed 60" output cable provides additional installation and application flexibility.

With its corrosion resistant aluminum housing, the Q-Can meets UL's requirements for dry, damp, and wet location ratings. Additionally this LED driver meets IP67 for liquid and solid ingress protection.

The LED driver performance features include high efficiency operation with installer friendly universal input voltage. A wide operating temperature range of -40°C to 60°C further enhances the Q-Can's application flexibility.

For maximum installation simplicity, application flexibility, and long reliable operation, look to the Signa Q-Can LED Driver.

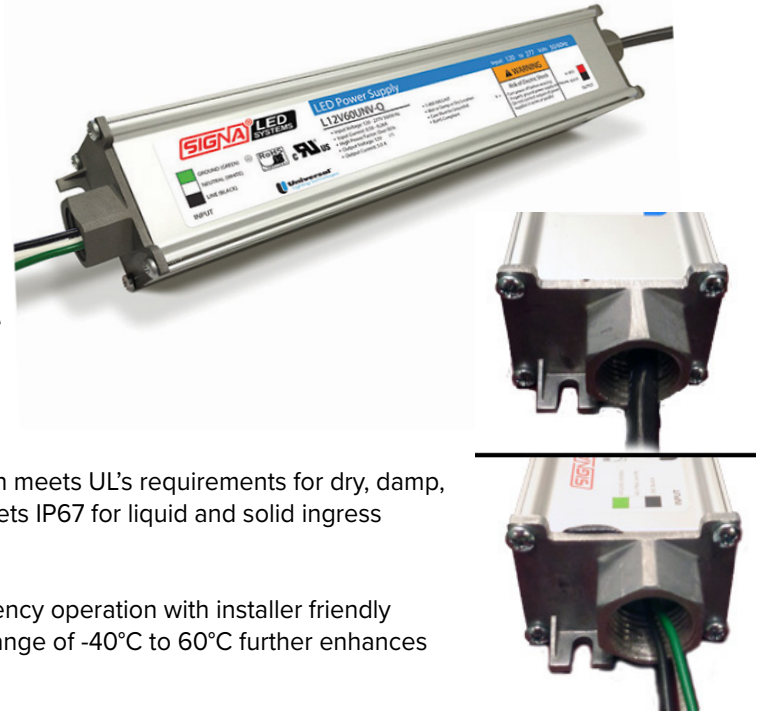

SKU: L12V60UNV-Q

Physical	
Length	10.7 in
Width	2.1 in
Height	1.5 in
Mounting Length	9.9 in w/ 0.9 in offset
Weight	1.7 lbs
Lead Lengths	
Blk, Wht, Grn	5 (A) max
Red, Blk (Jacketed)	60 W max

Specifications	
Input Voltage	120-277
Input Current Amps	0.58A/0.26A
Output Volts	12
Output Current	5.0
Output Watts	60
Location	Dry, Damp & Wet

Helpful Tip!

The lower the load on the LED Power Supplies, the longer they will last.

Always load LED Modules to the recommended manufacturer's power supply loading chart or do the math....

Example: 10 LED Modules

@ MOD Wattage: 1.08 per

= 10.8

+ 15% cushion = 1.62

= 12.42

In this instance, your final value is 12.42 putting you slightly over a 12 watt power supply (not offered) so a 20 watt power supply or larger would be necessary.

JS LED Power Supply

Applications

- Outdoor Signage
- LED Channel Letters
- Damp, Wet & Dry Locations

A **MJ-1220**

Waterproof WITHOUT NPT Threaded Nipple/Coupling

- 20 Watts Output, Constant Voltage or Constant Current
- Suitable in standard electrical junction boxes
- Waterproof Design within a 2x4 J Box, IP66, NEMA4,
- Convection Cooled, Plastic Housing, Dry or Damp Rated
- UL(cUL)1310, UL(cUL)48Class 2, FCC, CE Approved
- 3 Year Warranty

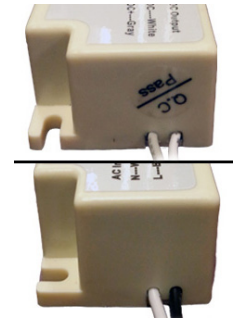

B **MJ-1240**

Waterproof WITHOUT NPT Threaded Nipple/Coupling

- UL8750, UL60950, LED Driver
- 40 Watts Output, Constant Voltage
- Water Protection (IP67)
- Convection Cooled, Aluminum Housing
- 100% full load burn-in test
- Class 2 Power Supply
- Protections: With OCP, OVP, SCP Protection & Auto Recovery
- 5 Years Warranty

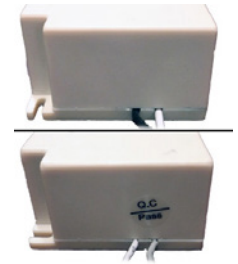

C **MJ-1260-100-277**

Wet Location WITH 1/2" NPT Male Thread at Both Ends

- 60 Watts Output, Constant Voltage or Constant Current
- Suitable for Dry, Damp, or Wet with proper terminations
- Waterproof Design, PFC
- Convection Cooled, Aluminum Housing
- UL1310, Class 2 output Certified
- With OCP, OVP, SCP Protection and Auto Recovery
- 3 Years Warranty

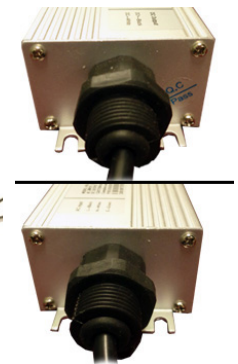

Item	Part Number	Input Voltage	Input Current Amps	Output Volts	Output Current	Output Watts	Measurements (inches)			Location
							L	W	H	
A	MJ-1220	120	0.6A	12	1.67A	20	3.75	1.5	1	Waterproof
B	MJ-1240	120	0.5A	11.4	3.3A	40	4	2.5	1.5	Waterproof
C	MJ-1260-100-277	120	1.4A	11.6-12.6	5A	60	9.25	2.25	1.5	Wet

Keystone LED Power Supply

Constant Voltage LED Pocket Drivers

- Small size without compromising performance
- Minimal shadowing
- Fits into a wide range of applications
- High power factor
- Multivolt input (120V/277V)
- Lightweight and easy to store
- Rigid aluminum case



The pocket driver packs a 60 or 100 watt punch despite being ¼ the size of a conventional driver!

SKU	Total Length	Mounting	Case Length	Height	Width
KTLD-60W-12V	5.67"	5.51"	5.12"	0.78"	0.78"
KTLD-100W-24V	5.94"	5.78"	5.40"	1.03"	0.78"

ACTUAL PRODUCT DIMENSIONS

60W KLTD-60W-12V



100W KLTD-100W-24V



ACCURATE MEASUREMENTS

Helpful Tip!

Overheating and Water Damage are two of the biggest causes of premature failure. Power Supplies should never be mounted at the bottom of an exterior sign where moisture is present. Even a weather sealed module or power supply requires adequate spacing and ventilation to dissipate heat build up. Power Supplies should always be mounted vertically on interior sides of exterior signage whenever possible.

Allanson Stormtight LED Dimmer

- Manual 0 - 100% brightness adjustment
- Compatible with all 12V and 24V Constant Voltage DC power supplies
- Eliminates current surges and maintains the life of LED's
- Can dim up to 5 Amp load (CV125-120)
- 12V and 24V LED modules can be dimmed by using this dimmer
- Convenient 4 wire plug in terminal block
- Simple one piece design

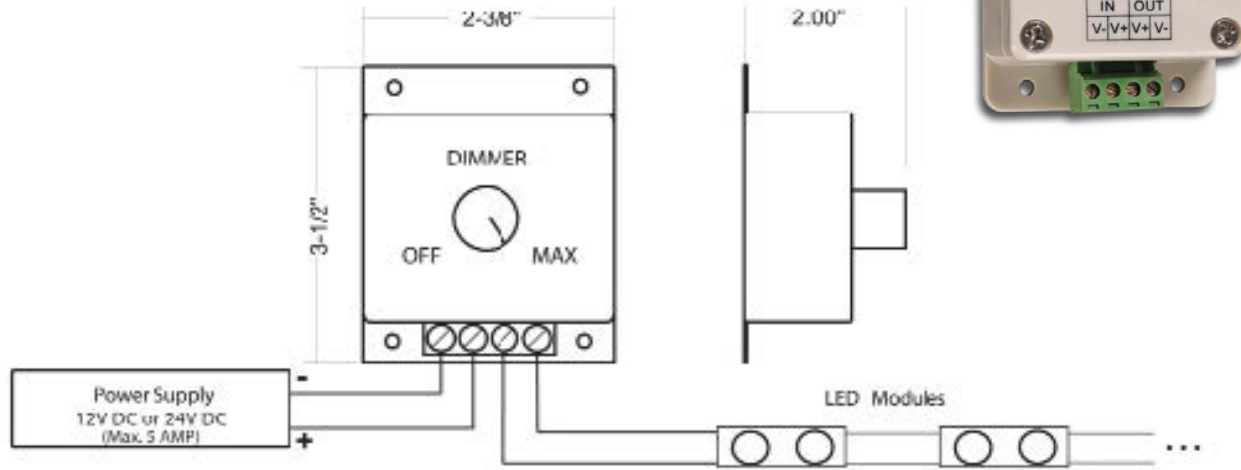

WallBuster LED Two-Part Through Wall Wiring Protection Device

- Two-part through wall wiring protection device
- Designed for LED channel letters
- Snap fit takes seconds
- 9/16 inch holes are all that is required
- No sharp metal edges in contact with insulated conductors
- UL Listed

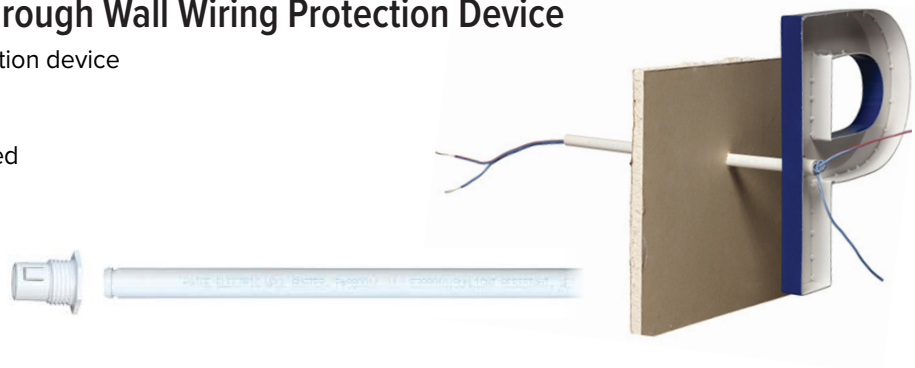

SKU

98P0014

Paige Power Supply Box LED Power Supply Box UL listed for Wet, Damp & Dry Locations!

- **Material** - 22 ga. Galvanized 2 piece box
- **Inside Dimensions**- 11.5" Tall x 7" Wide x 3" Depth
- **Lower Shelf** -Seven pre-punched knock-outs. One pre-drilled hole for ground lug
- **Inner Back Panel** - Raise for attachment of power source without damaging the integrity of the box back
- **Top of Sides and Bottom** - Pre-punched with air and condensation relief holes
- **Front Cover** - Fastening holes centered so attachment can be made either direction
- **Power Source Usage** -Will accommodate one or two standard size LED power sources. For power sources requiring 4" parallel clearance - Power sources must be mounted to sides



SKU

980054C

Paige Rip Strip: LED Plenum Wire **WITHOUT** Ground

This Cable consists of 2 conductor, 18 AWG stranded tinned copper conductor insulated with a Blue Polyvinyl Chloride jacket overall. **Plenum** UL Listed for sunlight resistant applications.

USE: A 2-18 AWG conductor LED WIRE for connecting low voltage DC power sources to LED modules. Can be used indoors or outdoors. *Available in 500 ft Spools.



SKU

98P183L-500'

Paige Plus: LED Wire Jacketed **WITHOUT** Ground

This Cable consists of 2 conductor, 18 AWG stranded tinned copper conductor insulated with Polyvinyl Chloride and a Polyvinyl Chloride jacket overall. UL listed sunlight resistant applications.

USE: A 2-18 AWG Conductor PLTC Cable for connecting low voltage DC power sources to LED modules. Can be used indoors or outdoors. *Available in 250 ft Spools.



SKU

984182C-250'

Helpful Tip!

Distance & Placement of power supply is extremely critical.

The importance of voltage drop for LED lighting is that an LED requires a minimum amount of current to properly light. Less than the minimum current can cause an LED to flicker, operate with less lumen output or shift in color.

Suggested LED to Power Supply Wire Gauge Chart

Expect a 3-5% Voltage Drop

12V VOLTAGE DROP AND WIRE LENGTH DISTANCE CHART

Wire Gauge	10W / .83A	20W / 1.67A	30W / 2.5A	40W / 3.33A	50W / 4.17A	60W / 5A
18 AWG	34 ft.	17 ft.	11 ft.	8 ft.	6 ft.	5 ft.
16 AWG	54 ft.	27 ft.	18 ft.	13 ft.	10 ft.	9 ft.
14 AWG	86 ft.	43 ft.	29 ft.	21 ft.	17 ft.	14 ft.
12 AWG	134 ft.	68 ft.	45 ft.	34 ft.	27 ft.	22 ft.
10 AWG	199 ft.	99 ft.	66 ft.	49 ft.	39 ft.	33 ft.

24V VOLTAGE DROP AND WIRE LENGTH DISTANCE CHART

Wire Gauge	10W / .42A	20W / .83A	30W / 1.25A	40W / 1.67A	50W / 2.08A	60W / 2.5A	70W / 2.92A	80W / 3.33A	96W / 4A
18 AWG	134 ft.	68 ft.	45 ft.	33 ft.	27 ft.	22 ft.	19 ft.	17 ft.	14 ft.
16 AWG	215 ft.	109 ft.	72 ft.	54 ft.	43 ft.	36 ft.	31 ft.	27 ft.	22 ft.
14 AWG	345 ft.	174 ft.	115 ft.	86 ft.	69 ft.	57 ft.	49 ft.	43 ft.	36 ft.
12 AWG	539 ft.	272 ft.	181 ft.	135 ft.	108 ft.	90 ft.	77 ft.	68 ft.	56 ft.
10 AWG	784 ft.	397 ft.	263 ft.	197 ft.	158 ft.	131 ft.	112 ft.	98 ft.	82 ft.

Fluorescent High Output Lamp Holders

Fluorescent High Output Lamp Holders provide excellent and durable housing for your fluorescent bulbs.

Features:

- 12" lead length
- Special thermoplastic flexible sealing material
- Expands and contracts with temperature changes
- Electrical connection protected from moisture
- Self extinguishing sealer adhesive
- Will not crack or deteriorate like clay-based sealers
- Electrical contacts remain rigid when expanded
- Electrical contact with lamp remains strong even after hundreds of relampings

Tombstone Lamp Holders Flush Mount Lamp Holders



SKU	TYPE
530-1K	Spring Loaded
530-2K	Stationary

SKU	TYPE
582-GDF	Stationary
583-GDF	Spring Loaded

Socket Sentry Boots

A gasket which provides a weather resistant shield on the bottom of a vertically installed fluorescent lamp to shed water or condensation.

SKU	QTY
582-BS	Sold as Singles



Fluorescent Awning Light Fixture

Standard High-Output, Low-Profile Fluorescent Light Fixtures. **UL Listed for Damp and Dry Locations.** Two Lamp Type with Energy-Efficient Low-Profile Electronic Ballast. Pre-finished 23-gauge Steel with White Baked-on Enamel. Can be used in a Continuous Run (or as a Single).

SKU	LENGTH
4-L248HO-DL	4'
6-L272HO-DL	6'
8-L296HO-DL	8'



Socket D-Punch

A machined steel die set used to punch a 1 1/32" "D" shaped hole in an aluminum or steel sheet for high output fluorescent lamp socket assembly. Punch and collar - D2 hardened steel; Base - 4140 steel Guides are removable and replaceable. Easy to use. Drill a hole for the pilot pin, place the sheet of metal and the punch over the pilot pin, drive the punch through the sheet with a hammer blow.



SKU	HOLE SIZE
D-PUNCH	1 1/32"

Disconnect Switch with Boot 20 amp

Extremely sturdy hardware, body and boot. Hand-soldered wire connection (not crimped) for best mechanical and electronic connection. The only switch rated for 20A at 120V and 277V 9.75" of lead wire. UL Package Toggle Switch/Boot approved for exterior use. Pre-assembled with ON/OFF face plate. UL/cUL Recognized for dry, damp, and wet locations when used with our included silicone boot.

SKU	CUT DEPTH
84630/84605	Black
84630/84610	Grey



Fluorescent Ballast Wire

- 14 AWG 19 strand copper wire
- 1000 Volt
- 500' spool
- Oil & sun resistant
- 9 colors available

SKU	COLOR	SKU	COLOR
14-BLK	Black	14-ORA-BLK	Orange & Black
14-BLUE	Blue	14-RED	Red
14-BROWN	Brown	14-WHT	White
14-GRN	Green	14-YEL	Yellow
14-ORANGE	Orange		

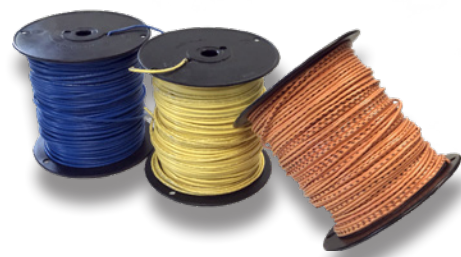

Keystone Ballast HO Electric (Conventional Wiring)

Wires exactly the same as traditional magnetic ballasts for seamless compatibility and installation. Weighs up to 50% less than heavy magnetic ballasts, providing easier transportation and installation. Delivers up to 15% savings over magnetic sign ballasts. Operates both T8HO and T12HO lamps. Solid-state technology enables excellent lamp starting performance in cold temperatures. Minimum Starting Temperature of -30° C/-20° F 120V Input Voltage; 50/60Hz; Series Wiring

SKU	# OF LAMPS	TOTAL LAMP FOOTAGE RANGE (FEET)																																																											
		1	2	3	4	5	6	7	8	9	10	11	12	13	14	15	16	17	18	19	20	21	22	23	24	25	26	27	28	29	30	31	32	33	34	35	36	37	38	39	40	41	42	43	44	45	46	47	48	49	50										
KTSB-E-0208-1	1																																																												
KTSB-E-0824-2-3	2 - 3																																																												
KTSB-E-0832-2-4	2 - 4																																																												
KTSB-E-1232-2-4	2 - 4																																																												
KTSB-E-2048-4-6	4 - 6																																																												

Sylvania High Output Lamps

Brighten your space quickly and easily with T12 fluorescent bulbs. Various lengths and diameters are available in order to meet your lighting requirements. Additionally, these bulbs come in color temperatures ranging from 4000K to 7000K and life spans lasting up to 12,000 hours. High-output fluorescent lights are great in numerous applications that demand more natural color.

Cool White - High Output

SKU	QTY	SIZE
F24T12/CW/HO	30 PK	24"
F30T12/CW/HO	30 PK	30"
F36T12/CW/HO	30 PK	36"
F42T12/CW/HO	30 PK	42"
F48T12/CW/HO	30 PK	48"
F60T12/CW/HO	30 PK	60"
F64T12/CW/HO	30 PK	64"
F72T12/CW/HO	30 PK	72"
F84T12/CW/HO	30 PK	84"
F96T12/CW/HO/CT	30 PK	96"

Daylight - High Output

SKU	QTY	SIZE
F18T12/D/HO	15 PK	18"
F24T12/D/HO	30 PK	24"
F30T12/D/HO	15 PK	30"
F36T12/D/HO	30 PK	36"
F42T12/D/HO	30 PK	42"
F48T12/D/HO	30 PK	48"
F60T12/D/HO	30 PK	60"
F64T12/D/HO	30 PK	64"
F72T12/D/HO	15 PK	72"
F84T12/D/HO	15 PK	84"
F96T12/D/HO/CT	15 PK	96"



Voltarc Long Lamp (Big Boys)

For bigger signs or longer letters, Voltarc's fluorescent sign long lamps reduce the number of wiring components, sockets and ballasts, while streamlining the construction process to achieve real savings compared to systems that use conventional shorter lamps. Installing 9- or 10-footers translates into fewer parts, fewer outages and less overall maintenance – adding to performance quality and cost-efficiency.

Big Signs Need Big Fluorescent Sign Lamps

Any time longer sign lamps would substantially reduce the number of lamps needed for a large sign, Voltarc's 9-foot and 10-foot sign lamps provide the best value and performance and can be used like every other straight high-output fluorescent lamp.

Cool White - High Output

SKU	QTY	SIZE
F108T12/CW/HO	12 PK	108"
F120T12/CW/HO	12 PK	120"

Daylight - High Output

SKU	QTY	SIZE
F108T12/D/HO	12 PK	108"
F117T12/D/HO	12 PK	117"
F120T12/D/HO	12 PK	120"



H/O Ballast Junction/Splice Box

Create splice boxes on the ends of the AT style ballasts, allow sign builders to use standard flexible conduit for wiring. Sizing - 2 15/16" x 3 1/16" x 2 3/8"

SKU: 17-051

Allanson Self-Regulating Outdoor - 30mA / 120V

15,000V unit replaces 15,000V / 12,000V / 10,500V / ratings. Available in conventional or enclosed. Poly-resin fill. 120V and 277V, 60Hz. Normal power factor. Ground fault protection. Mid-point ground design. Service button, LED diagnosis, auto-reset. Dimmable and flashable. 2 year limited warranty.



SKU	VOLTAGE
A-4B09N3-CB-S	5,000V - 9,000V
A-4B15N3-CB-S	9,000V - 15,000V

Allanson Standard Outdoor - 30mA / 120V

Allanson's "BPX" and "CPX" series include bypass, 3-Strike technology for ease of service and are designed for dependable nuisance-free performance. Recommended for outdoor neon signs. Secondary circuit ground fault protection, interrupting transformer output to eliminate the danger of a fire in case of an arc to ground. LED diagnostics, reduces troubleshooting time. Same dimension as all UL506 models, which means there is no need to redesign casings, raceways or existing signs in order to take advantage of a more reliable and safer transformer. A 29-minute by-pass switch, which enables efficient fault detection, in the same manner that you were accustomed to work with old UL506 transformers. Three automatic resets, eliminating nuisance tripping, providing continuous and better performance, thus saving service costs. Available in 277 and 347V, which results in potential cost savings, as you can install more transformers per circuit when compared to 120V applications.



SKU	VOLTAGE
7530CPX120	7,500V / 30mA
930CPX120	9,000V / 30mA
1230BPX120	12,000V / 30mA
1530BPX120	15,000V / 30mA

Allanson Self-Regulating/Self Enclosed – 30mA / 120V

9,000V unit replaces 9,000V / 7,500V / 6,000V / 5,000V / 4,000V / 3,000V ratings available in Conventional or Enclosed. Poly-Resin Fill. 120V and 277V, 60Hz. Normal Power Factor. Ground Fault Protection. Mid-point Ground Design. Service Button, LED Diagnosis, Auto-reset. Dimmable and Flashable. 2 Year Limited Warranty.

SKU	ADJUSTABLE VOLTAGE
A-4B09N3-EB-S	5,000V - 9,000V
A-4B15N3-EB-S	9,000V - 15,000V



Helpful Tip!

Reliability of the Luminous Tube Transformer:

Overloading of neon transformers may significantly affect life expectancy of the device. Additionally, external factors such as heat, moisture, and vibration can seriously effect the transformer.

Heat

The operating temperature of the transformer depends on the correct loading and proper mounting and installation. Transformers generate heat under normal operation and it is necessary to allow the heat to be expelled or dissipated.

Moisture

Whenever possible, mount the transformer in a clean, dry location. Electrical supply factors can affect the proper operation and life of the transformer.

Allanson Standard Self-Enclosed – 30mA / 120V

120v SELF ENCLOSED Transformer. Unitran Protector Self-Enclosed Style Transformer Recommended for indoor neon signs and indoor neon lighting. Outdoor non-weatherproof unitran enclosed design, providing pre-wiring for easy installation, eliminating the need for a transformer box and primary switch. Secondary circuit ground fault protection, interrupting transformer output to eliminate the danger of a fire in case of an arc to ground. Three automatic resets, eliminates nuisance tripping, provides continuous and better performance, thus saving service costs. A 29-minute by-pass switch, which enables efficient fault detection, in the same manner that you were accustomed to work with the old UL506 transformers. High power factor, 277 and 347 Volt models, which allows installation of more units on one circuit, saving material and labor costs.

SKU	SIZE
1230FPX120	12/30 120V
1530FPX120	15/30 120V
7530FPX120	75/30 120V



Allanson Indoor Electronic Window Style - 30mA / 120V

Proven SGFI technology - provides problem free sign operation. Intelligent diagnostic ground fault and open circuit protection - simplifies service. Smaller 3" w x 6" l x 1.5" h size - allows for more indoor sign installation options. 24" leads and sleeveless GTO15 - eliminates additional sleeving

SKU	VOLTAGE
SS635ICH	6,000V 1.0 Amp
SS935ICH	9,000V 1.5 Amp
SS1235ICH	12,000V 2.5 Amp



Ventex Channel Letter - 30mA / 120V

Open Circuit, Short Circuit Protection. UL 2161 Listed Utilizes Standard Gas Pressure. Self Adjusting Output On All Models. Automatic Overload Shutdown. 32 Inch H-V Output Leads. Use with Mercury or Neon. 1/2" Conduit Nipple On Primary. 36 Inch Input Wires Solid State Technology. Small Size/Lightweight. Complies w/CSA22.2, No. 1071, No. 13 Grounding Foot. High Power Factor. Line/Load Regulated

SKU	VOLTAGE
VT-120-CL4030	4,000V / 30mA
VT-120-CL6030	6,000V / 30mA
VT-120-CL9030	9,000V / 30mA
VT-120-CL1230	12,000V / 30mA



Ventex Transformer Enclosure Box

Rated for wet, damp and dry locations. UL 879 listed-certified by UL to Canadian Standards Grounding hardware installed on every box. Innovative design to maximize ventilation and extend the life of the power supply. Knock out for toggle switches. Convenient 1/2" conduit knock-outs. UL designation can be found on the top of the transformer lid.

SKU	SIZE
6000-SNGL	7" x 7" x 18"



Zinc Plated Prewired Tube Support Standard 1-3/4" Height

This tube support features a 10mm diameter threaded glass stand which is 1-3/4" from center of saddle to end of stem. The 10T3 has a two piece spring temper brass base that features two locking notches which hold the glass more securely than conventional one piece bases. The base is zinc plated brass and the unit comes pre-wired.

SKU	QTY
10T3	500 or Singles



Quik-Supports™ Fits tubing sizes 12mm to 15mm

Insulating tube support stand-offs for use with LED flex neon and high voltage legacy Neon installations. Original, secure "V-Grip" design clip rotates 360 degrees for easy installation. Two piece UV resistant clear polycarbonate construction. Ideal for dry, damp or wet location applications. Height adjustable from 1 3/4" to 2 1/4". UL 879 Listed by ETL.

SKU	QTY
QS-1	100 BG



Copper Tie Wire 22 AWG – 1LB

22 AWG (solid) tinned copper buss wire. To be used as neon tie down to tube supports.

SKU	DESCRIPTION
1LBTW	1 LB Spool



GTO-15 #14 With Integral Sleeve Silicone Insulation

Covers flexible neon sign gas tube oil burner ignition cable for indoor and outdoor use for 15,000 volt service. Construction consists of stranded tinned copper insulated with sunlight resistant dielectric. The silicone 14 construction eliminates GTO sleeving and covering in neon installations. 15,000 Volts / 150°C. =sUL Listed 879, RoHS Compliant. For use where sleeving is required UL 879 RoHS.

SKU	DESCRIPTION
GTO-981514	Black - 250'
GTO-981514WHT	White - 250'



Ceramic Cable Support With Machine Screws

SKU	QTY
CS-MS-SNGL	Sold as Singles



Slipstick High Tension Cable Bushing

The slipstick is commonly used as through wall insulation for high tension cables. The heavy wall Slipstick glass measures 12" long with an outside diameter of 19mm. A one way spring steel clip slips easily into adjustment and won't back off. The secure rubber shoulder and heavy wall glass insulating tubing ensures protection for high tension cables.

SKU	SIZE	QTY
SLIPSTICK12"	12"	Sold as Singles



Electro Short Sleeve Insulator

Used to insulate the connection between an electrode and GTO wire; an internal ring makes sleeves weather-tight. For dry or damp locations.

SKU	DESCRIPTION	QTY
88715	12mm - Black	Sold as Singles
88735	15mm - Black	Sold as Singles



Silicone Electrode Cap Insulator

The most durable & flexible silicone cap. Used by the world's largest POP manufacturers. Rated for 15,000 volts, 7,500 volts to ground, max current 60mA.

SKU	DESCRIPTION	QTY
88710	12mm - Black	Sold as Singles
88720	13mm - Black	Sold as Singles
88730	15mm - Black	Sold as Singles
88870	12mm/13mm - White	Sold as Singles
88880	15mm - White	Sold as Singles



Masters Electrode Insulator Boot

To prevent rain and snow from entering Small Glass Housing (#200) Receptacles.

SKU	DESCRIPTION	QTY
6287	Grey	Sold as Singles



Silicone Housing Cap

Neon electrode Insulator boot may be used on straight neon tubing or double-back applications.

SKU	DESCRIPTION	QTY
WPEC-13	13mm - Black	Sold as Singles
WPEC-15	15mm - Black	Sold as Singles



Federal Bushing White or Black

Porcelain, used to pass GTO wire through raceways. Comes with a 1/2" NPT thread and locknut. Fits into a 7/8" knockout.

SKU	DESCRIPTION	QTY
FEDB(1/2"NPT)	White	Sold as Singles
BO-PB3	Black	Sold as Singles



High Voltage Junction Box Wet Locations

Snap-on cover-no screw. 15,000V (7,500V to Ground). Staggered connection holes for seal-tight connectors. Constructed of durable injection-molded plastic with integral high-volt connection.

SKU	QTY
TC-HV II	Sold as Singles



Caps Housing

Provides effective installation for the GTO connection to the housing. UL listed for dry and damp at 7500 volts max, including 15,000 V mid-point. Referenced transformer installations. Fits #100, #200 and #200P Glass Housings or any 8-32 housing stud. Rigid plastic, igloo-shaped Glass housing must have Listed cap when used in a Wet Location. Igloo style cap must be used if the correct 1 1/2" spacing in the enclosure cannot be maintained.

SKU	DESCRIPTION
HC	Plastic / Sold as Singles

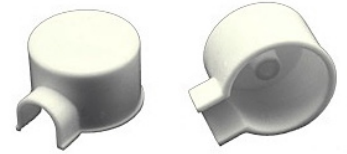

Brass Electrode Caps

Use on tubulated electrodes to protect the tubulation from damage. Use with any housing which utilizes a spring-type electrode contact. Made of brass to provide a positive electrical connection and resist corrosion. Available in 12mm and 15mm diameters, regular and long lengths.

SKU	DESCRIPTION
EC12R	12mm Short/Reg
EC15R	15mm Short/Reg
EC12L	12mm Long
EC15L	15mm Long



Blow Hose

Creating blown glass art is safer and easier with the Blowhose Assembly. Flexible design allows for comfortable position at the torch. Fittings prevent frit and powders from entering your mouth - creating a safer, cleaner environment.

SKU	SIZE
BLOW HOSE	6' Length



Neon Hand Block 1" x 3" x 7 1/2"

A combination of calcium silicate and fiber; contains no asbestos; withstands temperatures up to 1400°F; leaves no marking on neon tubing; will last for years.

SKU	QTY
NEON HAND BLOCK	Sold as Singles

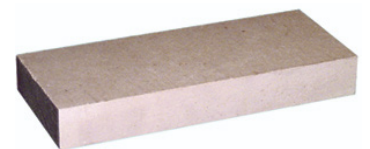

Inland 33 Vacuum Oil

Inland Vacuum offers a complete line of mechanical oils for all pump types and vacuum applications. Benefits of proper pump fluid selection include longer pump life and less back streaming which leads to a cleaner vacuum system and increased productivity. Our strict quality control procedures insure a product that is recommended by major manufacturers. Through close association with the major vacuum pump manufacturers and end users, Inland has learned how to manufacture vacuum fluids that enable the vacuum pump to attain its optimal performance for all vacuum applications.

SKU	SIZE
INLAND 33	1 Liter



Diffusion Pump Oil

The ideal diffusion pump oil would be thermally stable, non-volatile, chemically inert and non-toxic. Real diffusion pump fluids, on the other hand, represent compromises between these properties; no one fluid does it all. Inland offers a broad range of diffusion pump oils, including hydrocarbon, inert PFPE, polyphenyl ether and silicone fluids for a wide range of applications. These fluids include distilled hydrocarbons, silicones, organic esters and other synthetics. This wide selection ensures that we can supply the proper fluid for your application.

SKU	SIZE
INVOIL 705	1/2 Liter



ELECTRIC NEON

NEON ACCESSORIES

Metal Conduit Screw-In Connector Male & Female

For steel, reduced wall steel and aluminum flex metal conduit. Zinc die-cast.

SKU	SIZE
SCF12	1/2"
SCF38	3/8"
SC12	1/2"
SC38	3/8"



Neon/Fluorescent Pro Tube Tester

Convenient testing tool for trouble shooting. "Torch" shape design with body-fitting leather mini-case, perfect for carrying. Operates on 4 AA batteries.

SKU	DESCRIPTION
741150	Batteries Included



Peanut Glass Housing #200P

Mounting Hole: 1.375" / Neon Opening: 0.875"

*This housing installation shall be protected from all water sources such as rain and snow unless used in conjunction with our glass housing silicone front cap.

SKU	QTY
HO-200P/SINGLE	50 or Singles

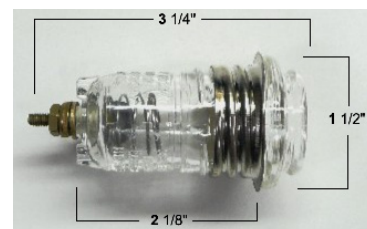

Large Glass Housing #100

Mounting Hole: 1 3/4" / Neon Opening: 1.375"

*This housing installation shall be protected from all water sources such as rain and snow unless used in conjunction with our glass housing front cap

SKU	QTY
HO-100/SINGLE	50 or Singles

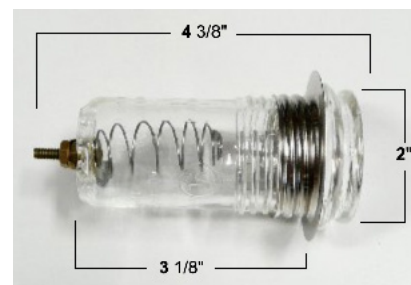

Small Glass Housing #200

Mounting Hole: 1.375" / Neon Opening: 0.875"

*This housing installation shall be protected from all water sources such as rain and snow unless used in conjunction with our glass housing silicone front cap.

SKU	QTY
HO-200/SINGLE	50 or Singles

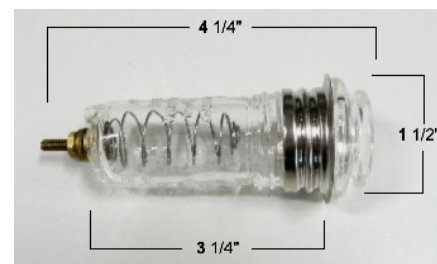

Small Porcelain Housing #200

SKU	QTY
TC-200/SINGLE	50 or Singles

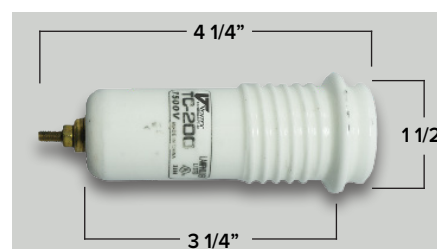

Neon Gas

Excellent for clear red units, or for coated tubing.

SKU	SIZE
NEONGAS/2.25LTR	2.25 Liter

Mercury .9lb

The finest quality mercury available for luminous tubes. Triple distilled for absolute purity. Packaged in glass container to maintain purity.

SKU	SIZE
MERCURY	.9lb



Extreme Cold Gas K4 Blue

The best for all-weather applications, from below-zero regions to the tropics. The high percentage of Neon in K4 provides the heat necessary to completely vaporize mercury under cold weather conditions. Mercury required. Proven 14 to 49% brighter than competitive cold weather gases by an independent laboratory.

SKU	SIZE
K4-GAS/2.25LTR	2.25 Liter

Glass Neon Tubing

VOLTARC® Neon Glass Tubing

NEPCO is a stocking distributor for all Voltarc Neon Glass Tubing. Voltarc offers single coated and double coated tubing in 4' lengths ranging from 8mm-15mm.

For more information or to view a neon color chart visit www.light-sources.com

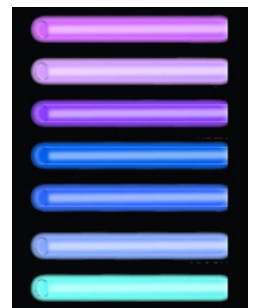

EGL® Accuwall

NEPCO is a stocking distributor of Accuwall Machine Drawn 5 foot colored glass tubing. Accuwall tubing is available uncoated or coated rare earth phosphor. Available mm sizes range from 8mm-15mm.

For more information or to view a color chart visit www.egl-lighting.com



VOLTARC® MASONLITE Millennium Electrodes

Combine the technologies of:

- Annealed lead glass for ease of welding to your sign tubing
- Superior plated shell and high tech emission coating for ease for conversion & longer life
- Wide mouth tubulation to maximize your evacuation process
- Hi-Tech ceramic collar centers arc stream - adds life to the tube
- Mica disk prevents flash back of arc stream within the tube

For more information or to view available electrodes visit www.light-sources.com





**NEPCO PRODUCTS HAS BEEN MANUFACTURING
NEON TO THE SIGN AND LIGHTING TRADE SINCE 1928**

Offering Custom Neon, Repairs and Stock Neon
PICKUP AND DELIVERY SERVICE AVAILABLE

OFFERING 84 STOCK NEON SIGNS



To view all stock neon signs, visit our website at www.nepcosignsupply.com

For questions or quotes, please contact **Richard Sutton**
1-800-327-7562, Ext. 113 or email r.sutton@nepcosignsupply.com

GE Silicone Adhesive/Sealer Clear

It creates a permanently waterproof seal with airtight adhesion. Adheres to: aluminum, brick, mortar, concrete, and most plastics.

SKU	SIZE
GE361	2.8 oz
GE012	9.8 oz



Weld-On 45 2-Part Structural Adhesive

Weld-On 45 is a two-component, high strength, high viscosity, reactive structural adhesive for bonding unprepared and corrosion resistant metals, composites, and plastics (e.g. ABS, acrylic, aluminum, brass, copper, galvanized steel, PETG, polycarbonate, and PVC).

***REQUIRES WELD-ON GUN FOR 50ML/400ML CARTRIDGES - SEE NEXT PAGE.**

SKU	SIZE
WO-45-50ML*	43 ml
WO-45-400ML/NEW*	400 ml



Weld-On 16 1-Part Acrylic/Plexi Adhesive

Weld-On 16 is a 1-part, **medium bodied**, fast-setting, high strength acrylic (plexi) cement. Also bonds rigid PVC, ABS, styrene, butyrate, polycarbonate to themselves and each other, as well as other plastics and porous surfaces.

SKU	SIZE
WO-16-5OZ	5 oz



Weld-On 3 Acrylic/Plexi Adhesive

Weld-On 3 is a **water thin**, non-flammable, very fast-setting solvent cement for bonding acrylic/plexi. It will also bond with other thermoplastics such as polystyrene, CAB (cellulose acetate butyrate), PETG (polyethylene terephthalate glycol) and polycarbonate to themselves. It will not bond to cross linked acrylics.

SKU	SIZE
WO-3-GAL	GALLON
WO-3-PT	PINT



Weld-On 66 Vinyl/Flex Adhesive

Weld-On 66 is a 1 part, **light bodied**, fast setting, versatile solvent cement for bonding flexible or rigid vinyl to itself or to urethane, leather, canvas, ABS, foamed PVC, butyrate, and wood. It bonds quickly upon contact with substrates and the bond strength will increase as solvent dissipates.

SKU	SIZE
WO-66-PT	Pint



Weld-On 58 Polycarbonate Adhesive

Weld-On 58 is a VOC-free, two-component, fast-setting, reactive, urethane-based adhesive for bonding a wide variety of thermoplastics, including polycarbonate, butyrate, PETG, anti static acrylic, ABS, PVC, polyurethane and foam board to themselves and one another. WELD-ON 58 is recommended for a variety of applications in the sign assembly industry, especially butyrate trimcap to polycarbonate in channel letter applications. It also has many uses in other plastic fabrication industries for bonding ABS to PETG. Excellent UV light resistance.

SKU	Size
WO-58-50ML	50 ml



Weld-On Manual Dispensing Gun 2-Part 43ml/50ml Cartridges

Manual Dispensing Gun (plastic frame) for 43 ml or 50 ml cartridges. Includes 1:1 and 4:1 Plungers

SKU	Size
WO-GUN-50ML	50 ml



Weld-On Gun High Resistance 2-Part 400ml Cartridges

A Manual Multi-Component Twin Cartridge Gun for use with between 450x450ml and 490x490ml twin cartridges featuring a static mixing nozzle. Accepts 10:1 Mix Ratio cartridges. High Thrust Drive. B-Line Multi-Component Dispensing Gun with smooth & powerful High Thrust 26:1 Ratio Drive. Albion's legendary Double Gripping Plates and steel trigger means increased durability. Manual Drive, Multi-Component Cartridge Gun. 490ml Twin Cartridge Capacity Thrust: 900 lbf, Pressure: 181 psi. 26:1 Drive. Accepts 10:1 Mix Ratio (450ml to 490ml) twin cartridges; Typically used for dispensing solid surface adhesives.

SKU	SIZE
WO-GUN-400-LT	400 ml



Weld-On Mixing Tips 50 or 400ml Cartridges

SKU	SIZE
WO-TIPS-50	50 ml
WO-TIPS-400/NEW	400 ml



Glue Applicator Bottles

SKU	SIZE
WO-APP-14	Thick Set 1 1/2" Needle
WO-APP-25	Thin Set 2" Needle



Thick Set 1 1/2" Needle



Thin Set 2" Needle

Coming Soon

Weld-On 30 is suitable for use in a variety of industries including sign assembly and many others where high bond strength and resistance to extreme environmental conditions is critical. They are especially suitable for bonding unprepared metals including Aluminium, CRS, and Stainless Steel; also suitable for bonding painted and coated metals. Has excellent adhesion to plastics such as PVC, polycarbonate, ABS, acrylic and thermoset deposits.

CONVERSION CHART

Fractions ♦ Decimals ♦ Millimeters

FRACTIONS	DECIMALS	MILLIMETERS	FRACTIONS	DECIMALS	MILLIMETERS	FRACTIONS	DECIMALS	MILLIMETERS
1/64	.015625	.3969	11/32	.34375	8.7313	43/64	.671875	17.0657
1/32	.03125	.7938	23/64	.359375	9.1282	11/16	.6875	17.4626
3/64	.046875	1.1906	3/8	.375	9.5250	45/64	.703125	17.8594
1/16	.0625	1.5875	25/64	.390625	9.9219	23/32	.71875	18.2563
5/64	.078125	1.9844	13/32	.40625	10.3188	47/64	.734375	18.6532
3/32	.09375	2.3813	27/64	.421875	10.7157	3/4	.750	19.0501
7/64	.109375	2.7781	7/16	.4375	11.1125	49/64	.765625	19.4470
1/8	.125	3.1750	29/64	.453125	11.5094	25/32	.78125	19.8438
9/64	.140625	3.5719	15/32	.46875	11.9063	51/64	.796875	20.2407
5/32	.15625	3.9688	31/64	.484375	12.3032	13/16	.8125	20.6376
11/64	.171875	4.3656	1/2	.500	12.7001	53/64	.828125	21.0345
3/16	.1875	4.7625	33/64	.515625	13.0969	27/32	.84375	21.4313
13/64	.203125	5.1594	17/32	.53125	13.4938	55/64	.859375	21.8282
7/32	.21875	5.5563	35/64	.546875	13.8907	7/8	.875	22.2251
15/64	.234375	5.9531	9/16	.5625	14.2876	57/64	.890625	22.6220
1/4	.250	6.3500	37/64	.578125	14.6844	29/32	.90625	23.0188
7/64	.265625	6.7469	19/32	.59375	15.0813	59/64	.921875	23.4157
9/32	.28125	7.1438	39/64	.609375	15.4782	15/16	.9375	23.8126
19/64	.296875	7.5406	5/8	.625	15.8751	61/64	.953125	24.2095
5/16	.3125	7.9375	41/64	.640625	16.2719	31/32	.96875	24.6063
21/64	.328125	8.3344	21/32	.65625	16.6688	63/64	.984375	25.0032

OUR MANUFACTURING PARTNERS



MEMBERSHIP ASSOCIATIONS



RI Sign Contractors Association



Northeast Canvas Products Association



Northeast States Sign Association



SIGN, GRAPHICS, AWNING & MARINE CANVAS SUPPLIES

125 Amaral Street, East Providence, RI 02915
1-800-327-7562 ♦ 401-438-4550 ♦ Fax: 401-438-1533

www.nepcosignsupply.com